



# BAKER COUNTY BOARD OF COUNTY COMMISSIONERS

## AGENDA April 7, 2026

### REGULAR SESSION 5:00 P.M.

- I. **INVOCATION AND PLEDGE OF ALLEGIANCE**
- II. **APPROVAL OF AGENDA**
- III. **ELECTED OFFICIALS**
- IV. **PUBLIC COMMENT**
- V. **APPROVAL OF CONSENT AGENDA ITEMS**
  1. Minutes- March 17, 2026 - Regular Session & Public Hearing (combined)
  2. Expense Report
  3. LPA Members Reappointment
  4. Approval of Cyber Security Grant Agreement
  5. Amendment 10 - Plant AS Inducement & Development Agreement
- VI. **NEW BUSINESS**

<ol style="list-style-type: none"><li>1. Approval of Proclamation- Sexual Assault Awareness Month; Mallory Warner</li><li>2. LPA Alternate Member Appointment- W. Chandler; Sara Little</li><li>3. Engagement Letter, BMO- Impact Fee/Spcl Asmnt Study; Peter Napoli</li><li>4. Resolution 2026-07 Budget Amendments; Brooklyn Nevill</li><li>5. Final Adoption of LHAP; Lydia Mangano</li><li>6. Award Bid 2025-16 CR229 N Paving; Chris Lee</li><li>7. Award CEI CR 229 N; Chris Lee</li><li>8. Resolution 2026-14 FDOT Traffic Signal Agrmnt FY27; Chris Lee</li><li>9. Approval of Opposition Letter- Water 1<sup>st</sup> N Florida; Sara Little</li><li>10. Proposed Non-Consensual Tow Rate Fee Discussion; Sara Little</li><li>11. Approval of Purchase- Shoals Park Playground Equipment; Sara Little</li><li>12. Approval of LSF Year 3 Opioid Funding Contract; Sara Little</li><li>13. Approval of Quotes- Animal Control Painting/Pressure Washing; Sara Little</li><li>14. Approval of TDC Funding Application- Beat the Heat; Sara Little</li><li>15. Approval of TDC Funding Application- July 4<sup>th</sup> Celebration; Sara Little</li><li>16. Approval of TDC Funding Application- Spring Blooms Market; Sara Little</li><li>17. Approval of TDC Funding Application- Baker Destination Guide; Sara Little</li></ol>	<b>Action Item</b> <b>Action Item</b> <b>Action Item</b> <b>Action Item</b> <b>Action Item</b> <b>Action Item</b> <b>Action Item</b> <b>Action Item</b> Info Only <b>Action Item</b> <b>Action Item</b> <b>Action Item</b> <b>Action Item</b> <b>Action Item</b> <b>Action Item</b> <b>Action Item</b>
-------------------------------------------------------------------------------------------------------------------------------------------------------------------------------------------------------------------------------------------------------------------------------------------------------------------------------------------------------------------------------------------------------------------------------------------------------------------------------------------------------------------------------------------------------------------------------------------------------------------------------------------------------------------------------------------------------------------------------------------------------------------------------------------------------------------------------------------------------------------------------------------------------------------------------------------------------------------------------------------------------------------------------------------------------------------------------------------------------------------------------------------------------------------------------------------------------------------------------------------------------------------------------------------------------------------------------------------	-----------------------------------------------------------------------------------------------------------------------------------------------------------------------------------------------------------------------------------------------------------------------------------------------------------------------------------------------------
- VII. **PRIOR BUSINESS**

<ol style="list-style-type: none"><li>1. FEMA Project Update</li><li>2. Pending Business Report</li><li>3. Expense Report Over \$5,000</li><li>4. American Rescue Plan Phase 1 &amp; 2</li></ol>	Info Only Info Only Info Only
--------------------------------------------------------------------------------------------------------------------------------------------------------------------------------------------------	-------------------------------------
- VIII. **COUNTY MANAGER**

**Continued to Second Page**

If any member of the public desires to appeal a decision made at these hearings, he or she will need a record of the proceedings and for that purpose he or she may need to ensure that a verbatim record of the proceedings is transcribed, which record would include the testimony and evidence upon which the appeal is to be based. In accordance with the American with Disabilities Act, persons needing a special accommodation of an interpreter to participate in these proceedings should contact the County Commissioners Office at (904) 259-3613, at least 48 hours prior to the time of the hearing. Please Note: Items marked as "information only" or "for discussion" may have Board action taken at the time of discussion.



## BAKER COUNTY BOARD OF COUNTY COMMISSIONERS

### AGENDA April 7, 2026

#### IX. COUNTY ATTORNEY

#### X. COMMISSIONER COMMENTS

#### XI. PUBLIC HEARING

##### Final Hearing Items:

1. Ordinance 2026-01 Small Scale Land Use Amendment- Nutty Buddy
2. Ordinance 2026-02 Rezoning- Nutty Buddy
3. Ordinance 2026-03 Rezoning – Parker
4. Ordinance 2026-04 Small Scale Land Use Amendment- Bailey
5. Ordinance 2026-05 Rezoning – Bailey

#### XII. ADJOURN

If any member of the public desires to appeal a decision made at these hearings, he or she will need a record of the proceedings and for that purpose he or she may need to ensure that a verbatim record of the proceedings is transcribed, which record would include the testimony and evidence upon which the appeal is to be based. In accordance with the American with Disabilities Act, persons needing a special accommodation of an interpreter to participate in these proceedings should contact the County Commissioners Office at (904) 259-3613, at least 48 hours prior to the time of the hearing. Please Note: Items marked as "information only" or "for discussion" may have Board action taken at the time of discussion.

## BAKER COUNTY BOARD OF COMMISSIONERS

### MINUTES

MARCH 17, 2026

The Baker County Board of Commissioners met at a scheduled meeting with the following members present:

Chairman, Ronald Mann (District 1)  
Commissioner, Jimmy Anderson (District 2) ABSENT  
Commissioner, Tyler Mobley (District 3)  
Commissioner, Blake Iverson (District 4)  
Commissioner, Mark Hartley (District 5)

Also Present:

County Attorney, Rich Komando  
County Manager, Sara Little  
Deputy Clerk, Peyton Qualter

*Note: These minutes are a summarized version of the actual discussions at the meeting; actual meetings can be viewed on Facebook. These are not verbatim transcripts*

### REGULAR SESSION 5:00 PM

Chairman Mann welcomed everyone in attendance.

#### **I. INVOCATION AND PLEDGE OF ALLEGIANCE**

Brother Jamie Hodges led the meeting in prayer and Pledge of Allegiance

#### **II. APPROVAL OF AGENDA**

Tyler Mobley moved to approve as presented. Commissioner Mark Hartley seconded the motion. County Manager Sara Little asked that pending business item 1 FEMA Projects update be moved under New Business item 6. Commissioner Tyler Mobley amended his motion with the modifications as requested. Commissioner Blake Iverson seconded the motion. The motion carried unanimously.

#### **III. ELECTED OFFICIALS**

There were no comments from elected officials at this time.

#### **IV. PUBLIC COMMENT**

Curtis McVickers comments on the school zone cameras and mentions a judgement made by Judge Deluka in Broward County. Concerns were raised in regard to violations, lawsuit risks, and penalties to the vehicle owner instead of the driver. Commissioner Mobley says the BOCC has the Ordinance to allow the school zones cameras. Commissioner Iverson comments that on the back of the ticket there is a section to address non-drivers to which the ticket was issued. County Attorney Komando assures the board that the judgement made in Broward County was regarding a red-light camera, not necessarily a school zone camera. Randy Crews understands Mr. McVickers, however, comments that the Sheriff's Department enforces the laws as they are written and assures the public that they are not doing anything that violates the communities' rights. Crews also notes that since school zone cameras have been active, violations went from 1,434 per day to 50 violations per day.

#### **V. APPROVAL OF CONSENT AGENDA ITEMS**

1. Minutes – March 3, 2026 – Regular Session & Public Hearing (combined)
2. Expense Report
3. E911 Grant Application

Commissioner Hartley motioned to approve consent agenda items. Commissioner Mobley seconded the motion. The motion carried unanimously.

#### **VI. NEW BUSINESS**

##### 1. Proclamation – Child Abuse Prevention; Amanda with Partnership for Strong for Strong Families

County Attorney Komando reads the Proclamation for Child Abuse Prevention Awareness at the request from the Partnership for Strong Families. Amanda Demario speaks of April being Child Abuse Awareness month and notes that there are 39 children in Baker County currently in foster care. Declaring April 2026 Child Abuse Prevention Month

Commissioner Hartley motions to approve the Proclamation as read. Commissioner Hartley seconds the motion. The motion carries unanimously.

## 2. Approval of Financing Terms – Solid Waste Truck; Sara Little

Loan proposal for the purchase of on e2025 Mack Roll Off Truck for the Solid Waste Department. . Ms. Little stated that per budget FY 25/26 Budget hearing BOCC of an annual payment of \$60,000.00 and asked staff to sought proposals for financing the 2025 Mack Roll Off Truck for the Solid Waste Department. Loan proposals were sought by County staff fir the five year financing of \$231,394. This purchase was included in the current fiscal year for an annual payment of \$60,000. County Manager Little requests to proceed with the loan proposed by First Federal with a rate of 5.89% and an annual payment of \$53,544 as it was the best option received by staff. Proposal from Nextran provided as second quote with a rate of 6.22% and an annual payment of \$55,261. The truck is due to be delivered at any time. Staff recommends proceed with loan proposed from First Federal.

Chairman Mann asks for any comments from the board. There were no comments.

Commissioner Hartley motioned to approve the financing term. Commissioner Mobley seconded the motion. The motion carried unanimously.

## 3. Rental Rates and Project Update Sanderson Center; Sara Little/Doug Moore

Mr. Moore stated the renovations completed are the new windows and ADA compliant bathroom, this was budgeted for in our current fiscal year. Doug Moore gives updates on the Sanderson Center, and says he personally installed a lift station and saved money by not hiring a contractor. Mr. Moore says he would like to take the money saved and turn it over to other improvements such as outside lighting and hopes for a small pavilion with an outside grill in the future. Mr. Moore discussed unexpected repairs that are now completed costing \$2,000 (not counting electrical work) and has a suggestion for a 5-member committee to help maintain the Sanderson Center.

Chairman Mann asks for comments from the board. Chairman Mann expresses appreciation for all that Mr. Moore has done towards this project to make the Sanderson Center a useable facility but agrees that there is more work to be done. Commissioner Hartley says parking is an issue that needs to be looked at. Commissioner Mobley asks about rental fees and how they correlate to the Ag Center. County Manager Little says the Sanderson Centers current rate for a private event was raised by \$50, making it \$175, commercial events went from \$150 to \$225; church events remain at \$50, and the refundable deposit remains at \$150

Chairman Mann asked for any further comments from the board. Commissioner Iverson asks who has overseen the maintenance thus far. County Manager Little says the County

Maintenance Department is over the Sanderson Center. Commissioner Iverson asks if 5 people are found for the committee, will they be responsible for everything and is a landscaper needed. Mr. Moore says the community will take care of the Sanderson Center and if there are major needs, it will be brought before County Manager Little and the District Commissioner, and a lawn Service contract is in place that covers the Sanderson Center.

Commissioner Mobley motions to Approve the proposed rates for the Sanderson Center. Commissioner Iverson seconds the motion. The motion carries unanimously.

#### 4. CDBG Revised Applicant List; Spencer Nabors

Mr. Nabors stated the application list was approved by BOCC at the February 17, 2026 and requests approval for applicant swap (previously approved applicant has obtained assistance from another source). Next applicant on the homeowner list to be approved.

Chairman Mann asks for comments from the board. No comments presented.

Commissioner Mobley motions to approve the remove and replace as presented. Commissioner Iverson seconds the motion. The motion carries unanimously.

#### 5. CDBG Revised Contractor List; Spencer Nabors

Mr. Nabors stated the application list was approved by BOCC on February 17, 2026, and requests acceptance of additional contractor to contractors list. The contractor has submitted a qualification packet to bid on the program, certified in roofing construction, and meets all the requirements for Baker County Housing Assistance Plan.

Commissioner Mobley asks how many contractors on the list are local. Spencer Nabors says three out of six.

Commissioner Mobley motions to approve the additional contractor to the list. Commissioner Hartley seconds the motion. The motion carries unanimously.

#### 6. FEMA Project Update; Dennis Schmitz

## FEMA Projects

Project	Awarded Company	BOCC Award Date	Status	Start Date	Completion Date	Cost
RFP 2025-06 23A Box Culvert	J.D. Hinson Co.	8/5/2025	Pending Obligation Notice to Proceed Issued			\$1,125,000.00
RFP 2025-07 Boat Ramp	Nordic Group/AMI	8/5/2025	Pending Obligation Notice to Proceed Issued			\$548,000.00
RFP 2025-10 Steel Bridge Road	J.B. Coxwell Cont.	8/5/2025	Pending Scope and Cost Development			\$1,798,759.23
RFP 2025-11 Turner Cemetery Bridge	Gulf Coast Underground, LLC	8/5/2025	Pending Scope and Cost Development Notice to Proceed Issued			\$827,570.00
RFP 2025-14 Shoals Park	TimPREP	1/20/2026	Pending EHP Review			\$497,857.00
Completed Project Countywide 61 Roads	Completed by County Staff	NA	Pending Obligation			

Dennis Schmitz says FEMA is currently shut down but this does not affect the progress on the boat ramp. Schmitz reports that a design concept for the boat ramp should be presented to the board for approval at the April 7<sup>th</sup> meeting.

Commissioner Mann clarifies the 23A speed limit has been changed per the FDOT and repairs must be made. The county will come up with a funding plan to complete the project. FEMA's portion is \$141,000. There is funding available in the current budget to support the project. A presentation will go before the board at the next meeting.

Chairman Mann asks for any comments from the board. No comments presented.

Colleen gives updates on needs assessments and discusses challenges for families that need assistance. Colleen says the food pantry is open and active at the Keller Center and a clothing closet and housing items will be open in April.

### 7. Approval of Payment – FY 23/24 Inmate Medical; Randy Crews

Approval of invoice BCSO for payment to YesCare. This is for the inmate medical charges for FY 23/234. This invoice requires BOCC approval. Invoice total is \$200,252.45. We have budgeted this however, funds budgeted were for FY 24/25 payment. Once future invoices are received, a budget amendment will be required as FY 23/24 will use the budgeted total

Commissioner Mobley asked for the reasoning for the delay. Mr. Crews says it's not abnormal for them to be delayed, this was the first year with YesCare and errors in billings needed corrected. The issues were within the cooperate office.

Commissioner Hartley asks if the charges are overage. The total was \$350,252; \$200,000 was budgeted and \$150,000 is built into the agreement with the medical provider. 5 inmates had extended hospital stays accounted for \$154,321.

YesCare is an annual contract.

Commissioner Mobley motions to approve the invoice total of \$200,252.45 to YesCare. Commissioner Hartley seconds the motion. The motion carries unanimously.

#### 8. Resolution 2026-08 FDOT SA for CR 229 N; Chris Lee

FDOT Supplemental Funding Agreement for CR229 N from Verdie Dorman to 3.9 miles North. This agreement adds an additional \$766,044.83 to cover the budget shortfall for this project based on the low bid submitted. Chris Lee requests the approval of the Resolution and agreement as submitted. This is not in our current budget; a budget amendment will be required

Chairman Mann asks for any comments from the board. There were no comments.

Commissioner Mobley motions to approve Resolution 2026-08 and read by title. Commissioner Hartley seconds the motion. County attorney Komando reads Resolution 2026-08 by title. The motion carries unanimously.

#### 9. Resolution 2026-09 FDOT Bridge Replacement – Cedar Creek; Chris Lee

FDOT Bridge Replacement for CR 229 over Cedar Creek. This Resolution supports FDOT project to replace the bridge at CR229 over Cedar Creek. FDOT will deliver this project using Federal Funding and does not require a match from the County, FDOT direct project. Setting date of project is scheduled for 01/26/2028. This will not come through the County Budget. Chris Lee requests the approval of the Resolution and agreement as submitted.

Chairman Mann asks for any comments from the board. There were no comments.

Commissioner Hartley motions to approve Resolution 2026-09 and read by title. Commissioner Mobley seconds the motion. County Attorney Komando reads Resolution 2026-09 by title. The motion carries unanimously.

#### 10. Resolution 2026-10 FDOT Temp Const Easement – Cedar Creek; Chris Lee

FDOT is acquiring right of way for the purpose of creating a temporary detour easement over the parcel. Tying in, conforming, harmonizing, and/or reconnecting existing grade, slope pavement, drainage, utility driveway, walkway, turnout, and/or other features located on or within the real property adjacent to CR 229 over Cedar Creek Bridge. Chris Lee requests the approval of Resolution and temporary easement as submitted.

Chairman Mann asks for comments from the board. Commissioner Mobley asks if this is for a temporary construction easement. County Manager Little explains and responds yes.

Commissioner Mobley motions to approve Resolution 2026-10. Rich Komando read Resolution 2026-10 by title. Commissioner Hartley seconds the motion. The motion carries unanimously.

#### 11. Resolution 2026-11 FDOT Bridge Replacement – Reynolds; Chris Lee

FDOT Bridge Replacement for Reynolds Bridge. This Resolution supports FDOT project to replace the bridge at CR120 (Reynolds Bridge) over N Prong St Mary's River. FDOT will deliver this project using Federal Funding and does not require a match from the County, FDOT direct project. This will not come through the County budget. Setting date of project is scheduled for 12/15/2027. Chris Lee requests the approval of the Resolution and agreement as submitted.

Chairman Mann asks for comments from the board. Commissioner Iverson asks for a timeline on the project. Chris Lee responds saying it goes out to bid on 12/15/2027 and they have until 2029.

Commissioner Hartley motions to approve Resolution 2026-11 and read by title. Commissioner Mobley seconds the motion. County Attorney Komando reads Resolution 2026-11 by title. The motion carries unanimously.

#### 12. Resolution 2026-12 FDOT Bridge Replacement – Richardson Rd.; Chris Lee

FDOT Bridge Replacement at Richardson Rd. This Resolution supports FDOT project to replace the bridge at Richardson Road over S Prong St Mary's River. FDOT will deliver this project using Federal Funding and does not require a match from the county, FDOT direct project. Setting date of project is scheduled for 02/28/2029. This will not come through County budget. Chris Lee requests the approval of the Resolution and agreement as submitted.

Commissioner Hartley motions to approve Resolution 2026-12 and read by title. Commissioner Mobley seconds the motion. County Attorney Komando reads Resolution 2026-12 by title. The motion carries unanimously.

#### 13. Resolution 2026-13 FDOT Lighting Agreement; Chris Lee

FDOT Highway Lighting Maintenance and Compensation Agreement. This is an annual agreement between the County and FDOT to provide funds for the maintenance of lighting/traffic lights along US90 at Wildcat Drive, CR231, Olustee Battlefield, and Cypress Street. The agreement totals \$13,616.54 and is in our current FY budget. Chris Lee requests the approval of the Resolution and agreement as submitted.

Chairman Mann asks for any comments from the board. Commissioner Mobley asks how often inspections are done. Chris Lee says as issues are discovered, FDOT will be notified, and comments that there is a \$13,000 cap amount but says the cap amount have never been exceeded, however if the cap amount is exceeded, FDOT will still fix the issues. Commissioner Mobley comments that any maintenance needs to be documented.

Commissioner Hartley motions to approve Resolution 2026-13 and read by title. Commissioner Iverson seconds the motion. County Attorney Komando reads Resolution 2026-13 by title. The motion carries unanimously.

#### 14. Midpoint Commons Fee Reduction Request; LaDonna Combs

Recently a pre-application meeting was held with the applicant for Midpoint Commons to discuss the application and process. A portion of the application is based on the acreage of the property (\$20 per acre), and every application remains with this fee. This acreage fee has remained consistent for 25 years with the only change being the advertisement fee. The applicants have submitted a letter proposing a fee reduction associated with a land use and zoning change for Midpoint Commons due to the size. The total acreage for this request is 2,134 acres and totals out to roughly \$86,000 in application fees (large scale land use amendment and PUD zoning).

The applicant requests to pay an initial \$15,000 upfront for each application (\$30,000) and if the review costs exceed that amount, the balance would be replenished as needed. The estimate they have is based on the number of acres they intend to use within the 2,134 acres. LaDonna Combs says historically land use and zoning fees have never been waived or reduced and notes that there were two cases with large acreage (1100 acres and 3600 acres) that both applicants paid the fees in full.

Other counties were sought out for similar circumstances. LaDonna says some counties capped their acreage fees once 1,000 acres was reached, however, there was not a consistent answer from the counties. County Attorney Komando notes that most counties charge for the pre-application meeting, however Baker County does not charge for the meeting as a courtesy.

Representative Richie Schultz explains the method behind the request saying it's best to propose the acreage they plan to use and makes it clear that the applicants aren't looking for any help and they will respect the board's decision.

Chairman Mann asks for comments from the board. Chairman Mann says the estimated cost is a lot less than what the fee would originally be and makes it clear that the applicant would be responsible for replenishing if needed and expresses concerns that the volume of the project would exceed in-house capabilities. Commissioner Mobley discusses fees from other counties and says the county, nor the taxpayers should be responsible for covering any of the cost for this project and expresses concern about setting precedence for the next developer coming to Baker County. Commissioner Iverson says that asking for a fee reduction is the opposite of gaining trust from the community and has concern with further corners being cut. Chairman Mann expresses that he is uncomfortable with waving the fees. County Attorney Komando states that the request is withdrawn. After lengthy discussion, the applicant withdrew the request.

#### 15. Year 3 LSF/Opioid Funding Budget; Sara Little

Year 3 LSF Opioid Funding for local programs. This year funding allocation totals \$203,519 and will be used to continue 3 existing local programs. BCFR Paramedicine Program (\$41,975); Baker Prevention Coalition/Peer Specialist Position (\$53,900); Baker Medical Services ROC Program (\$107,644). County Manager Little requests approval for year 3 as submitted.

Chairman Mann asks for any comments from the board. No comments presented at this time.

Commissioner Mobley motioned to approve year 3 as submitted. Commissioner Hartley seconded the motion. The motion carries unanimously.

## **VII. PRIOR BUSINESS**

# Pending Business

PENDING BUSINESS ITEM	PRIORITY	STATUS	START DATE	% COMPLETE	COMMENTS
COA Bus Wash	Normal	In Progress	08/06/2019	100%	Project Closeout Complete
Infrastructure funding for County Roads	Normal	New	07/18/2017	50%	Ongoing
St Marys Cove Boat Ramp Grant Phase 1	High	In Progress	01/01/2020	100%	Project was completed but destroyed by Hurricane Debby before closeout was complete. FWC will require boat ramp reconstruction before final closeout is done.
St Marys Cove Boat Ramp Grant Phase 2	High	New	01/05/2020	100%	Project Closeout Complete
St. Mary's Shoals Park Improvements	High	New	10/19/2021	50%	Both site attendees are on site!
Council on Aging- Senior Life Enrichment Ctr	High	New	08/17/2022	100%	Project Closeout Complete
Cuyler Fire Station	High	New	01/03/2023	90%	Waiting on Mobile home. Pending Grand Opening.
Knabb Sports Complex Appropriation Project	High	New	11/21/2023	95%	Phase 2 to begin June 15.
Courthouse Generator Appropriation Project	High	New	11/21/2023	60%	Equipment Installed. Switch being installed currently. Full building connected April 11. Will NOT require building shut down.
Sanderson Center	Normal	New	12/03/2024	0%	Work underway.
Community Development Permit Software	Normal	New		75%	Programming is nearing completion. Staff will undergo training in coming weeks

County Manager Little presented the expense report over \$5,000 without comment

Phase	ARPA PHASE 1 & 2	Description	Budgeted Amount	Expended Amount	Notes
1		Building Construction Field Fire Forces	\$244,871	\$244,871	Central Fire Approved for Payment 7/15/2022
1		Emergency Services Communication Upgrade	\$300,000	\$303,063.05	
1		Road Infrastructure Improvements - Reid Stafford & Millage	\$250,000	249,727	Millage Purchased, Reid Stafford awarded 6/2023 Elevator = 25,150; Library Rise = \$125,000; Sanderson Station Propane Tank \$10,000; Sanderson Station Signage \$5,000; \$10,000 Vet Park Decks; Vet Park Power/FPL Costs \$14,000; \$15,900 Health Department Kojaks Door Repair; \$14,500 Joesville Park Boundary Survey; \$ 6,040.2-factor Authentication Key - Microsoft; \$1252 Library AC; \$3,000 trees at Post Office; \$26,742 Sanderson Fire Pump; \$52.50 Turbo work for Pond at Central County; <b>\$40,134 COA Change Order #2-19-072 Courthouse Keyless Entry Emergency Doors; \$67,735 Sanderson FS to FPL; \$6,700 Sanderson FS to Homestead; \$32,150 Sanderson FS to Sprinklermatic; \$28,866 Courthouse Generator</b>
1		Facilities Infrastructure Improvements - Library, Admin, CDD, Fairgrounds	766,223	567,726.00	
1		County Infrastructure Improvements - litter, overtime & lawn services	185,000	60,155	
1		Incentive Pay to Eligible Workers	\$488,750	488,750	
		<b>TOTAL</b>	<b>\$2,836,850</b>	<b>\$2,506,284</b>	
2		BOCC Emergency Services Communication Phase 2	900,000	803,762.15	803,762.15 paid, 10% payment remaining
2		Maint Replacement Vehicle	35,000	47,119	Purchased
2		Ag Ctr Replacement Tables	8,400	8,110.00	Purchased
2		Ext Replacement Laptop	1,000	1039	Purchased
2		Vet Svcs Vehicle	35,000	42,601	Purchased
2		Rec Replacement Vehicle	40,000	47,119	Purchased
2		Rec Park Equipment	50,000	11,005	Joesville Fencing = 4,450; Bleachers = 26,019; Knabb Fence Repair and Material \$18,721; Joesville Park Fence Replacement \$1705
2		Rec Demo 2-Story Association Booth	10,000	14,300	Miscy awarded 2/7
2		Rec Replacement Mower	13,000	16,067	Purchased
2		Rec Replacement Field Groomer	13,000	14,595.00	Purchased
2		Rec Knabb Sports Complex Improvements- APPROPRIATION MATCH FUND	305,000	308,417	\$6,681 survey; \$76,600 irrigation; \$4,800 hydroseeding; \$61,490 concrete sidewalks and deposit pads; Privacy Fence and Tree Removal at Knabb; \$5,000; Vet Park and Joesville- Ground Cover, Border \$13,431; \$1,522; need for volleyball courts 5/20; \$33,840 fill dirt; \$11,900 clay \$14,493 sand; \$59,700 fencing
2		Div/Op Security Related	10,660	10,660	*Currently charged to Div/Op- needs to be moved to ARPA via scanning
2		Div/Op Large Format Scanner	8,000	7,612	Scanner Purchased \$4641 \$2369 for Inkjet; Table \$528
2		Fire Sanderson Fire Station	600,000	600,000	Complete
2		Fire Cuyler Fire Station	250,000	64,119	bathroom, driveway, garage door conversion
2		Fire Thermal Camera	10,000	13,650	Purchased
2		Transport Replacement Office Fans	2,000	0	
2		Transport Replacement Equipment	5,000	1725	3 - Lucas Chest Compression Mounts
2		Recce Resilient/Plastic Floor Plate and Flooring	50,000	23,400	Plate and Flooring Complete
2		S/V Replacement Compressor Unit	34,500	31,336	Purchased
2		S/V Replacement of Dumpsters - 40 yard	27,500	20,406	Purchased
2		S/V Replacement of Dumpsters - 20 Yard	19,000	26,150	Purchased
2		S/V Replacement of Collection Site Attendant Building	5,000	4,234	All items been installed 04/23/2024
2		S/V Collection Site Improvements	55,000		\$6,6654 Slips Cutter; Computer/Client; gate at steel bridge collection sit
2		S/V Collection Site Security Camera	10,000	7,541	
2		BCSD Body Worn Camera	39,661	39,661	Purchased
2		Court Fac. Security Improvements	200,000	230,160	Elevator Update = 2 \$50,264; Key Card System \$179,316; New
2		Em Mng. Transfer Switch	50,000	20,000	Purchased
2		Contingenc Contingency	6,593	0	
		<b>TOTAL</b>	<b>2,836,850</b>	<b>2,522,908.15</b>	

### 1. Pending Business Report

COA bus wash, St. Mary's Cove boat ramp phase 2, and Senior Life Enrichment Center has been closed out and removed from the pending business report. County Manager Little gives updates on St. Mary's Cove Boat Ramp phase 1, Shoals Park, Kyler Fire Station, Knabb Sports Complex appropriation project, Courthouse Generator Appropriation Project, Sanderson Center, and Community Development Software.

### 2. Expense Report over \$5,000

No comments at this time.

### 3. American Rescue Plan Phase 1 & 2

Finance Director Brooklyn is prepared to present the budget amendment at the next BOCC meeting.

## **VIII. COUNTY MANAGER**

County Manager Little plans the quorum for next BOCC meeting due to Spring Break. BOCC will continue with regular scheduled meeting on April 7<sup>th</sup>.

## **IX. COUNTY ATTORNEY**

No comments at this time.

## **X. COMMISSIONER COMMENTS**

Commissioner Mobley discusses Blue Hole Rd. improvements and opening day of Little League.

Commissioner Iverson gives a shout out to the road department for all the work that they do and commends the project manager. Commissioner Iverson asks for an update on the survey related to the impact fee implementation.

Commissioner Hartley asks if Commissioner Anderson met with the COA facility for outstanding repairs. County Manager Little confirmed the meeting and the existing repairs.

Chairman Mann mentions a meeting at Suwannee Water Management and surrounding counties opposing treated sewage being dumped from Jacksonville to Suwannee. Chairman Mann would like Baker County to oppose the pipeline as well.

## **XI. PUBLIC HEARING**

### **FIRST HEARING ITEMS**

#### **1. Ordinance 2026-01 Small Scale Land Use Amendment – Nutty Buddy; LaDonna Combs**

(Companions with Ordinance 2026-02)

Small Scale Land Use with the request of AG B to Very Low Residential. The property is currently 5 acres but is separated into two 2.5 acres for tax purposes.

While the addresses currently associated with the subject property reflect Hill Lane, the recorded easement does not provide access through Hill Lane. The recorded easement goes around and comes out on Gaskins Circle. Fire Chief Nelson says issues with access and roads need to be improved to support the weight of a fire apparatus since it does not abut a currently maintained County Road. The issues need to be addressed with Engineered Roadway Plans that follow NFPA 1 for Fire Apparatus.

Chairman Mann called for public comments. Hearing none, Chairman Mann called for Commissioner Comments. There were no comments.

#### **2. Ordinance 2026-02 Rezoning – Nutty Buddy; LaDonna Combs**

Rezoning with the request of AG 10 to Residential Conventional Mobile Home 2.5.

This property is currently considered non-conforming. The applicant intends to bring the parcels into compliance with current standards in order to place a mobile home on each lot and sell them.

Chairman Mann asks for comments from the board. Commissioner Iverson mentions gates on the property, however, LaDonna Combs says if the property has gates, they must be unlocked.

Chairman Mann asks for comments from the public. Speaker Maruq Williams says she owns the parcel along the road and expresses concerns about potential traffic.

Chairman Mann asks for further comments. There were no more comments at this time.

Chairman Mann called for Commissioner comments. There were no comments.

### 3. Ordinance 2026-03 Rezoning – Parker; LaDonna Combs

Rezoning with the request of AG 7.5 to AG 5. This property is 10 acres total and made up of two parcels (9 acres and 1 acre). The parcel is currently in compliance with current zoning standards. However, the applicant's intention is to split the property evenly between two siblings, thus creating two parcels, each containing 5 acres. One sibling currently owns the 1-acre parcel. An additional process would be required to subdivide the property any further in the future. FEMA flood zone does not touch the parcel but is noted to be close by.

Chairman Mann asks for comments from the board. Commissioner Hartley asks if both portions of the property have access to the road. LaDonna responds, saying both have road frontage on Clet Harvey Rd. LaDonna Combs comments that the intention is to have one point of access with a shared driveway.

Chairman Mann called for public comments. Hearing none, Chairman Mann asks for further comments from the board. There were no more comments at this time.

### 4. Ordinance 2026-04 Small Scale Land Use Amendment – Bailey; LaDonna Combs

(Companions with Ordinance 2026-05)

Small Scale Land Use Amendment with the request of AG B to Very Low Density Residential. It was not the applicant's intention to request a one-acre density because it did not fit the request.

This parcel was created prior to current zoning standards. The applicant intends to bring the parcel into compliance with current zoning standards, as well as prepare for the creation of a 2.5-acre family lot. The property is currently 5.01 acres total.

Chairman Mann called for public comments. Hearing none, Chairman Mann called for Commissioner comments. There were no comments.

### 5. Ordinance 2026-05 Rezoning – Bailey; LaDonna Combs

Rezoning with the request of AG 7.5 to Residential Convention al Mobile Home 2.5.

An additional process would be required to subdivide the property any further in the future.

Chairman Mann asks for comments from the board. Commissioner Iverson asks if the property owners are willing to remove the garage to place a driveway. LaDonna responds saying the garage meets the setback to allow the driveway. Property Owner Raymond Bailey says the driveway from the street goes all the way back to the further 2.5 acres. It is outside of the easement, but does go all the way to the back (55 ft. from the property line).

Chairman Mann called for public comments. Hearing none, Chairman Mann called for Commissioner comments. There were no comments.

**XII. ADJOURN**

Chairman Mann adjourned the meeting at 7:50 pm

---

Clerk of Court/Clerk to the Board

---

Chairman, Ronald Mann

Bank Number: 1 / Name: First Federal / Description: Operating Account

Payment Number	Type	ID	Name	SRC	Num INV	Gross Amount	Discounts	Net Pay	Payment Date	HP Void	Batch
989168	CHK	A	BAKER PREVENTION COALITION, IN 26 Baker Days 80%-TDC	394	1	1,200.00 1,200.00	.00 0.00	1,200.00 1,200.00	03/13/2026		24275
989169	CHK	A	DAVIS & DAVIS ENTERPRISES Fuel Feb26-Fire Fuel Nov25-Jan26-Fire	1886	2	1,027.15 568.97 458.18	.00 0.00 0.00	1,027.15 568.97 458.18	03/13/2026		24275
989170	CHK	A	DEPENDABLE HTG, A/C & ELECTRIC AC Service Call-HD	145	1	150.00 150.00	.00 0.00	150.00 150.00	03/13/2026		24275
989171	CHK	A	DUVAL FORD R70 Diesel Oil Change-EMS	165	1	223.84 223.84	.00 0.00	223.84 223.84	03/13/2026		24275
989172	CHK	A	HAGAN ACE HARDWARE OF MACCLENN ST90 Pipe Ctr/Sandcloth/Cp-EMS Water 24pk 2x/Bulb-Main ST90 Elbw/Thread Cmpnd/Sle-EMS Roller/Roller Frame-Adm Cpl/Plug/Adptr/Tee/Cement-Main PVC Tee/Stock-Main Phone Charger-Main Roof Screws 2x-Main UT1 Oil Premix/Screws,Nut-Fire Oil Premix/Adpt/Crevice T-Main UT1 Screw Extractor 2x-Fire	221	11	531.52 82.38 23.93 64.18 92.18 78.22 8.99 25.75 61.66 37.34 43.20 13.69	.00 0.00 0.00 0.00 0.00 0.00 0.00 0.00 0.00 0.00 0.00 0.00	531.52 82.38 23.93 64.18 92.18 78.22 8.99 25.75 61.66 37.34 43.20 13.69	03/13/2026		24275
989173	CHK	A	HENRY SCHEIN INC Bndg/Epi/Syringe/Nitroglyc-EMS	588	1	373.13 373.13	.00 0.00	373.13 373.13	03/13/2026		24275
989174	CHK	A	IN TOUCH CONSULTING GROUP, INC CDBG ADMINISTRATOR FEES	4599	1	4,218.75 4,218.75	.00 0.00	4,218.75 4,218.75	03/13/2026		24275
989175	CHK	A	JIMMY'S AUTOMOTIVE REPAIR INC # 979 spark plugs,coil,upp-Adm	1105	1	634.57 634.57	.00 0.00	634.57 634.57	03/13/2026		24275
989176	CHK	A	L V HIERS INC 26.90Gal Fuel-Rec 35.90Gal Fuel-Maint 213Gal Diesel-Shoals 400GAL DYED DIESEL-EMS 21.80Gal Fuel-Rec 31.10Gal Fuel-Rec 10Gal Fuel-Maint 25.60Gal Fuel-Maint 32Gal Fuel-Rec 32.50Gal Fuel-Rec	267	10	2,385.40 71.72 95.74 621.96 1,188.00 58.14 82.95 26.67 68.25 85.32 86.65	.00 0.00 0.00 0.00 0.00 0.00 0.00 0.00 0.00 0.00 0.00	2,385.40 71.72 95.74 621.96 1,188.00 58.14 82.95 26.67 68.25 85.32 86.65	03/13/2026		24275
989177	CHK	A	MIRACLE AUTOMOTIVE & TRUCK SER B20 HORN WIRING/AIR LEAK-Fire	296	1	1,513.46 1,513.46	.00 0.00	1,513.46 1,513.46	03/13/2026		24275
989178	CHK	A	NAPA AUTO PARTS- JAX015 Wheeled Battery Charger-Shoal #38 10W30 Oil,Tub O Towel-Main	284	2	273.56 195.00 78.56	.00 0.00 0.00	273.56 195.00 78.56	03/13/2026		24275
989179	CHK	A	ROBERT'S OXYGEN COMPANY INC ST90 Wrench/Brass Shut Off-EMS	4306	1	184.81 184.81	.00 0.00	184.81 184.81	03/13/2026		24275

Bank Number: 1 / Name: First Federal / Description: Operating Account

Payment Number	Type	ID	Name	SRC	Num INV	Gross Amount	Discounts	Net Pay	Payment Date	HP Void	Batch
989180	CHK	A	TELADOC HEALTH INC TELADOC 3.26	1016 3510131	1	1,374.10 1,374.10	.00 0.00	1,374.10 1,374.10	03/13/2026		24275
989181	CHK	A	TOM NEHL TRUCK COMPANY E70 SERVICE;OIL,FUEL FILT-Fire	410 11142602S	1	788.60 788.60	.00 0.00	788.60 788.60	03/13/2026		24275
989182	CHK	A	TOWN OF GLEN ST MARY ACC#272-00 3.26	2074 SEPT21-068	1	300.38 300.38	.00 0.00	300.38 300.38	03/13/2026		24275
989183	CHK	A	VERIZON WIRELESS Wireless Transmit Jan-Feb26 Wireless Transmit Jan-Feb26	1710 6135691966 6135691966	2	180.37 180.37 180.37	.00 0.00 0.00	180.37 90.19 90.18	03/13/2026		24275
989184	CHK	A	WESCO TURF INC Mower Svc Call/Filter/Oil-Rec	4525 48854118	1	374.31 374.31	.00 0.00	374.31 374.31	03/13/2026		24275
989185	CHK	A	GW CUSTOMS LLC #38 cab door opening frame-Mai	4621 194	1	3,415.20 3,415.20	.00 0.00	3,415.20 3,415.20	03/13/2026		24277
1904	EPAY	A	FSEBT-FLORIDA SHERIFFS EMPLOYE COBRA 3.26	4486 1COBRA11.24-042	1	55.38 55.38	.00 0.00	55.38 55.38	03/13/2026		24275
1905	EPAY	A	FSEBT-FLORIDA SHERIFFS EMPLOYE ACCIDENT 3.26	4486 ACCIDENT11.24-042	1	310.38 310.38	.00 0.00	310.38 310.38	03/13/2026		24275
1906	EPAY	A	FSEBT-FLORIDA SHERIFFS EMPLOYE DENTAL 3.26	4486 DENTAL11.24-042	1	3,898.49 3,898.49	.00 0.00	3,898.49 3,898.49	03/13/2026		24275
1907	EPAY	A	FSEBT-FLORIDA SHERIFFS EMPLOYE HEALTH 3.26	4486 HEALTH11.24-042	1	82,608.00 82,608.00	.00 0.00	82,608.00 82,608.00	03/13/2026		24275
1908	EPAY	A	FSEBT-FLORIDA SHERIFFS EMPLOYE HOSPITAL 3.26	4486 HOSPITAL11.24-042	1	337.02 337.02	.00 0.00	337.02 337.02	03/13/2026		24275
1909	EPAY	A	FSEBT-FLORIDA SHERIFFS EMPLOYE CRITICAL ILLNESS 3.26	4486 ILLNESS11.24-042	1	213.80 213.80	.00 0.00	213.80 213.80	03/13/2026		24275
1910	EPAY	A	FSEBT-FLORIDA SHERIFFS EMPLOYE LIFE 3.26	4486 LIFE11.24-042	1	1,387.73 1,387.73	.00 0.00	1,387.73 1,387.73	03/13/2026		24275
1911	EPAY	A	FSEBT-FLORIDA SHERIFFS EMPLOYE STD 2.26	4486 STD11.24-042	1	321.04 321.04	.00 0.00	321.04 321.04	03/13/2026		24275
1912	EPAY	A	FSEBT-FLORIDA SHERIFFS EMPLOYE VISION 3.26	4486 VISION11.24-042	1	617.11 617.11	.00 0.00	617.11 617.11	03/13/2026		24275
989186	CHK	A	ALACHUA COUNTY BOARD OF COUNTY ME Mar26	14 ME2026-31	1	11,909.92 11,909.92	.00 0.00	11,909.92 11,909.92	03/16/2026		24288
989187	CHK	A	ALLEN NORTON & BLUE FY25-26 annual retainer fee 12	4646 190469	1	2,500.00 2,500.00	.00 0.00	2,500.00 2,500.00	03/16/2026		24288
989188	CHK	A	CHARLES L LEWIS JR DBA LEWIS I Lawn Irrigation Maint 2.26-CH	4425 426	1	150.00 150.00	.00 0.00	150.00 150.00	03/16/2026		24288
989189	CHK	A	DELL FINANCIAL SERVICES LLC	1023	1	70.00	.00	70.00	03/16/2026		24288

Bank Number: 1 / Name: First Federal / Description: Operating Account

Payment Number	Type	ID	Name	SRC	Num INV	Gross Amount	Discounts	Net Pay	Payment Date	HP Void	Batch
			Computer Lease 006 Buy Out	4984613		70.00	0.00	70.00			
989190	CHK	A	FLORIDA MUNICIPAL INSURANCE TR	1182	1	156,445.00	.00	156,445.00	03/16/2026		24288
			Q3 FY25-26 Comm Prop/Crime/Mar	2526-0024-Q3-2		156,445.00	0.00	156,445.00			
989191	CHK	A	HOUNDTOWNE INC. DBA SHELTERLUV	1190	1	10.00	.00	10.00	03/16/2026		24288
			Adoption Sftwr 5xAdptns-AC	71724		10.00	0.00	10.00			
989192	CHK	A	L V HIERS INC	267	6	377.45	.00	377.45	03/16/2026		24288
			20.50Gal Fuel/2.7Gal Mari-Main	196390		63.78	0.00	63.78			
			32Gal Fuel-AC	196475		85.31	0.00	85.31			
			18Gal Fuel-CD	196781		55.90	0.00	55.90			
			22.30Gal Fuel-Maint	196791		69.27	0.00	69.27			
			20.20Gal Fuel-Extn	607944		53.86	0.00	53.86			
			18.50Gal Fuel-AC	608031		49.33	0.00	49.33			
989193	CHK	A	NAPA AUTO PARTS- JAX015	284	2	72.85	.00	72.85	03/16/2026		24288
			E50 Coupling 5x-Fire	47198		57.95	0.00	57.95			
			E50 Air Brake Hose 10x-Fire	47200		14.90	0.00	14.90			
989194	CHK	A	P & R ELECTRIC INC	306	1	2,935.00	.00	2,935.00	03/16/2026		24288
			Feed to Street/Trnsfomr-VetPrk	9178		2,935.00	0.00	2,935.00			
989195	CHK	A	SHOWCASE ADVERTISING INC	1150	1	20.00	.00	20.00	03/16/2026		24288
			Name Plate Jury Room 1	986		20.00	0.00	20.00			
989196	CHK	A	SIXTH STREET VETERINARY HOSPIT	878	1	65.00	.00	65.00	03/16/2026		24288
			Veterinary Services 3/3/26	203095		65.00	0.00	65.00			
989197	CHK	A	STACIE D. HARVEY, CLERK OF COU	279	1	30.00	.00	30.00	03/16/2026		24288
			RES26-2,4,5,6 Recorded	202601183		65.50	0.00	30.00			
989198	CHK	A	STAPLES ADVANTAGE	2164	1	19.64	.00	19.64	03/16/2026		24288
			Disinfectant Wipes 2x-Adm	6056843459		19.64	0.00	19.64			
989199	CHK	A	TARBOX CONSULTING AND DESIGN I	484	3	8,655.50	.00	8,655.50	03/16/2026		24288
			Enterprise East Infrastructure	1743		6,483.00	0.00	6,483.00			
			All In Strg/Otter Run/FPL-CD	1745		632.50	0.00	632.50			
			All In Strg/Church of God/O-CD	1754		1,540.00	0.00	1,540.00			
989200	CHK	A	VERIZON WIRELESS	1710	2	642.09	.00	642.09	03/16/2026		24288
			CAD Jan-Feb26	6136854716		642.09	0.00	321.05			
			CAD Jan-Feb26	6136854716		642.09	0.00	321.04			
989201	CHK	A	VERIZON WIRELESS	1710	5	1,191.31	.00	1,191.31	03/16/2026		24288
			VERIZON Jan/Feb26	6136920413		1,191.31	0.00	786.71			
			VERIZON Jan/Feb26	6136920413		1,191.31	0.00	235.06			
			VERIZON Jan/Feb26	6136920413		1,191.31	0.00	110.97			
			VERIZON Jan/Feb26	6136920413		1,191.31	0.00	22.50			
			VERIZON Jan/Feb26	6136920413		1,191.31	0.00	36.07			
989202	CHK	A	ADVANCED TIRE SERVICE, LLC	2372	3	1,829.68	.00	1,829.68	03/20/2026		24361
			#2806 4 11R24.5 tires /rd inv	4023210		1,456.64	0.00	1,456.64			
			#4113 Tires 2x-Rd	4023280		263.04	0.00	263.04			
			#806 Wheel Balance-Rd	4023293		110.00	0.00	110.00			

Bank Number: 1 / Name: First Federal / Description: Operating Account

Payment Number	Type	ID	Name	SRC	Num INV	Gross Amount	Discounts	Net Pay	Payment Date	HP Void	Batch
989203	CHK	A	AIRGAS USA, LLC	1218	2	691.55	.00	691.55	03/20/2026		24361
			cylinder rental 6x Jan 2026/rd	5522388640		570.64	0.00	570.64			
			Acetylene Cylinder-Rd	9168974362		120.91	0.00	120.91			
989204	CHK	A	BAKER COUNTY PRESS	56	1	251.68	.00	251.68	03/20/2026		24361
			Ad for Bids Proj2025-16-Rd	77985		251.68	0.00	251.68			
989205	CHK	A		1062	1	5,447.51	.00	5,447.51	03/20/2026		24361
			HRA Reimbursement FY25-26	HRA2FY25-26		5,447.51	0.00	5,447.51			
989206	CHK	A	CINTAS DISTRIBUTION LLC-ROAD	4479	3	1,442.04	.00	1,442.04	03/20/2026		24361
			Rd Uniforms Cleaned 2/16	4259747178		480.68	0.00	480.68			
			Rd Uniforms Cleaned 2/23	4260515075		480.68	0.00	480.68			
			Rd Uniforms Cleaned 3/2	4261258499		480.68	0.00	480.68			
989207	CHK	A	FLEET TRUCK PARTS INC	4484	1	255.70	.00	255.70	03/20/2026		24361
			#313 Butt Connector/Battery-Rd	534338		255.70	0.00	255.70			
989208	CHK	A	FLORIDA GULF & ATLANTIC RAILRO	1208	1	2,470.00	.00	2,470.00	03/20/2026		24361
			RR Crossing 2025 annual mainte	2943213		2,470.00	0.00	2,470.00			
989209	CHK	A	FLORIDA POWERTRAIN & HYDRAULIC	193	1	50.04	.00	50.04	03/20/2026		24361
			#8357 Electric Cable-SW	1100633		50.04	0.00	50.04			
989210	CHK	A	GLEN CASH STORE INC	212	1	319.98	.00	319.98	03/20/2026		24361
			Bahia/Ryegrass/Hay Bale-Rd	A236500		319.98	0.00	319.98			
989211	CHK	A	HAGAN ACE HARDWARE OF MACCLENN	221	1	47.86	.00	47.86	03/20/2026		24361
			Cable Ties/Coupler/Sprayer-Rd	357105		47.86	0.00	47.86			
989212	CHK	A	HOMETOWN ELECTRICAL COMPANY	1610	1	700.00	.00	700.00	03/20/2026		24361
			remove/replace light pole-Rd	24-3055		700.00	0.00	700.00			
989213	CHK	A	L V HIERS INC	267	11	14,059.83	.00	14,059.83	03/20/2026		24361
			1066 gals dyed diesel/rd inv 0	196129		3,059.42	0.00	3,059.42			
			Used Oil Pickup-Rd	196270		150.00	0.00	150.00			
			hydraulic oil pump repair/rd i	196346		612.96	0.00	612.96			
			1999 gals dyed diesel/rd inv 4	493011		6,096.96	0.00	6,096.96			
			614 gals dyed diesel/rd inv 49	493035		1,872.70	0.00	1,872.70			
			10Gal Hydraulic Oil-Rd	607865		80.00	0.00	80.00			
			100 2.5 gals jugs blue DEF/rd	607924		1,200.00	0.00	1,200.00			
			27.60Gal Fuel-Rd	607963		73.59	0.00	73.59			
			123.40Gal Diesel/4Gal DEF-Rd	607966		416.96	0.00	416.96			
			106.30Gal Diesel-Rd	607974		317.84	0.00	317.84			
			60Gal Diesel-Rd	607976		179.40	0.00	179.40			
989214	CHK	A	NAPA AUTO PARTS- JAX015	284	9	931.75	.00	931.75	03/20/2026		24361
			#140 Fitting/Reel/Hose/Clam-Rd	46368		161.78	0.00	161.78			
			#6457 1Qt Oil 2x/Fuse-Rd	46420		22.97	0.00	22.97			
			#5362 Fuel Filter-Rd	46522		63.69	0.00	63.69			
			#8357 Hose/Fitting/Adapters-SW	46656		290.88	0.00	290.88			
			#1643 Trailer Hub Caps-Rd	46789		47.84	0.00	47.84			
			#6457 Hyd Filter/Adptr/Epox-Rd	46805		57.77	0.00	57.77			
			#1212 Reel/Fittings/Hose-Rd	47013		166.93	0.00	166.93			
			#58 Fuel Filter 2x-Rd	47015		48.94	0.00	48.94			
			#7210 Wheel Valve 5x-SW	47035		70.95	0.00	70.95			

Bank Number: 1 / Name: First Federal / Description: Operating Account

Payment Number	Type	ID	Name	SRC	Num INV	Gross Amount	Discounts	Net Pay	Payment Date	HP Void	Batch
989215	CHK	A	NEXTRAN TRUCK CENTER	318	3	3,365.58	.00	3,365.58	03/20/2026		24361
			#197 gray cloth seat with arm	04P216944		657.00	0.00	657.00			
			#6457 Pressure SEnsor-Rd	04P217821		117.84	0.00	117.84			
			#6457-senor repairs/rd inv 04W	04W36412.02		2,590.74	0.00	2,590.74			
989216	CHK	A	PRITCHETT TRUCKING INC	344	1	10,427.70	.00	10,427.70	03/20/2026		24361
			20 loads limerock/rd inv 14627	146274		10,427.70	0.00	10,427.70			
989217	CHK	A	RING POWER CORPORATION	365	2	809.60	.00	809.60	03/20/2026		24361
			#446 Element/Filter/Kit-Rd	07BC0004188		448.09	0.00	448.09			
			#348 Pump Kit-Rd	07BC0004265		361.51	0.00	361.51			
989218	CHK	A	ROBERT'S OXYGEN COMPANY INC	4306	1	66.79	.00	66.79	03/20/2026		24361
			Terminal Connector 2x-Rd	184213		66.79	0.00	66.79			
989219	CHK	A	SAFETY-KLEEN SYSTEMS INC	373	1	125.03	.00	125.03	03/20/2026		24361
			30G Washer Solvent-Rd	99106366		125.03	0.00	125.03			
989220	CHK	A	SCOTTY RHODEN, SHERIFF	757	1	2,434.00	.00	2,434.00	03/20/2026		24361
			School Zone Enforcement 2.26	3453		2,434.00	0.00	2,434.00			
989221	CHK	A	SCOTTY RHODEN, SHERIFF	757	1	18,587.07	.00	18,587.07	03/20/2026		24361
			E911 12.25	3464		18,587.07	0.00	18,587.07			
989222	CHK	A	SCOTTY RHODEN, SHERIFF	757	1	465.89	.00	465.89	03/20/2026		24361
			EMPG Grant G0525 Claim #4	3467		465.89	0.00	465.89			
989223	CHK	A	SCOTTY RHODEN, SHERIFF	757	1	5,578.60	.00	5,578.60	03/20/2026		24361
			EMPG Grant G0575 Claim #1	3468		5,578.60	0.00	5,578.60			
989224	CHK	A	VALIC	419	1	1,055.00	.00	1,055.00	03/20/2026		24361
			AIG VALIC 3/20	PR168-140		1,055.00	0.00	1,055.00			
1913	EPAY	A	FIRST FEDERAL BANK OF FLORIDA-	667	1	164.56	.00	164.56	03/20/2026		24350
			Tape 2x/Dog Food 5x-AC	MAR26		164.56	0.00	164.56			
1914	EPAY	A	FIRST FEDERAL BANK OF FLORIDA-	667	1	45.29	.00	45.29	03/20/2026		24350
			Library Books 3x-StAid	MAR26.10		45.29	0.00	45.29			
1915	EPAY	A	FIRST FEDERAL BANK OF FLORIDA-	667	1	228.99	.00	228.99	03/20/2026		24350
			Office Chair-StAid	MAR26.11		228.99	0.00	228.99			
1916	EPAY	A	FIRST FEDERAL BANK OF FLORIDA-	667	1	180.00	.00	180.00	03/20/2026		24350
			Chat GPT Subscription 3.26	MAR26.12		180.00	0.00	180.00			
1917	EPAY	A	FIRST FEDERAL BANK OF FLORIDA-	667	1	58.80	.00	58.80	03/20/2026		24350
			Email Accounts 3.26	MAR26.13		58.80	0.00	58.80			
1918	EPAY	A	FIRST FEDERAL BANK OF FLORIDA-	667	1	88.20	.00	88.20	03/20/2026		24350
			2 Year SSL Subsc-Shoals	MAR26.14		88.20	0.00	88.20			
1919	EPAY	A	FIRST FEDERAL BANK OF FLORIDA-	667	1	18.97	.00	18.97	03/20/2026		24350
			3V Batteries-Lib	MAR26.15		18.97	0.00	18.97			
1920	EPAY	A	FIRST FEDERAL BANK OF FLORIDA-	667	1	86.86-	.00	86.86-	03/20/2026		24350
			Pant Return-EMS	MAR26.16		86.86-	0.00	86.86-			

Bank Number: 1 / Name: First Federal / Description: Operating Account

Payment Number	Type	ID	Name	SRC	Num INV	Gross Amount	Discounts	Net Pay	Payment Date	HP Void	Batch
1921	EPAY	A	FIRST FEDERAL BANK OF FLORIDA- Pant Return-EMS	667	1	86.86- 86.86-	.00 0.00	86.86- 86.86-	03/20/2026		24350
1922	EPAY	A	FIRST FEDERAL BANK OF FLORIDA- Tax Refund Jackets-Fire	667	1	12.60- 12.60-	.00 0.00	12.60- 12.60-	03/20/2026		24350
1923	EPAY	A	FIRST FEDERAL BANK OF FLORIDA- Tax Refund Jacket-Fire	667	1	6.30- 6.30-	.00 0.00	6.30- 6.30-	03/20/2026		24350
1924	EPAY	A	FIRST FEDERAL BANK OF FLORIDA- Frames 3pk 2x-AC	667	1	15.94 15.94	.00 0.00	15.94 15.94	03/20/2026		24350
1925	EPAY	A	FIRST FEDERAL BANK OF FLORIDA- E10 Body Repair/ESTEEL FLAT;AL	667	1	727.28 727.28	.00 0.00	727.28 727.28	03/20/2026		24350
1926	EPAY	A	FIRST FEDERAL BANK OF FLORIDA- Pants 4x-EMS	667	1	139.96 139.96	.00 0.00	139.96 139.96	03/20/2026		24350
1927	EPAY	A	FIRST FEDERAL BANK OF FLORIDA- Pants 2x-EMS	667	1	86.86 86.86	.00 0.00	86.86 86.86	03/20/2026		24350
1928	EPAY	A	FIRST FEDERAL BANK OF FLORIDA- Pants 2x-EMS	667	1	86.86 86.86	.00 0.00	86.86 86.86	03/20/2026		24350
1929	EPAY	A	FIRST FEDERAL BANK OF FLORIDA- Addtnl Phone Storage 2.26-EMS	667	1	2.99 2.99	.00 0.00	2.99 2.99	03/20/2026		24350
1930	EPAY	A	FIRST FEDERAL BANK OF FLORIDA- ST90 5Gal Trailer Wash 4x-EMS	667	1	299.96 299.96	.00 0.00	299.96 299.96	03/20/2026		24350
1931	EPAY	A	FIRST FEDERAL BANK OF FLORIDA- ST50 5Gal Trailer Wash-Fire	667	1	74.99 74.99	.00 0.00	74.99 74.99	03/20/2026		24350
1932	EPAY	A	FIRST FEDERAL BANK OF FLORIDA- Practice Safety Treat-Paramed	667	1	64.94 64.94	.00 0.00	64.94 64.94	03/20/2026		24350
1933	EPAY	A	FIRST FEDERAL BANK OF FLORIDA- Button Down Shirt 4x-Fire	667	1	163.95 163.95	.00 0.00	163.95 163.95	03/20/2026		24350
1934	EPAY	A	FIRST FEDERAL BANK OF FLORIDA- UT1 BOOSTER HOSE/SHUTOFF-FIRE	667	1	2,183.00 2,183.00	.00 0.00	2,183.00 2,183.00	03/20/2026		24350
1935	EPAY	A	FIRST FEDERAL BANK OF FLORIDA- Bleach/Cleaner/Lndry Dtrgnt-AC	667	1	55.04 55.04	.00 0.00	55.04 55.04	03/20/2026		24350
1936	EPAY	A	FIRST FEDERAL BANK OF FLORIDA- UT1 LED Red-Fire	667	1	130.82 130.82	.00 0.00	130.82 130.82	03/20/2026		24350
1937	EPAY	A	FIRST FEDERAL BANK OF FLORIDA- UT1 Pedestal Horn 4x-Fire	667	1	147.32 147.32	.00 0.00	147.32 147.32	03/20/2026		24350
1938	EPAY	A	FIRST FEDERAL BANK OF FLORIDA- ST70 Pine Sol 2ct-Fire	667	1	65.45 65.45	.00 0.00	65.45 65.45	03/20/2026		24350
1939	EPAY	A	FIRST FEDERAL BANK OF FLORIDA- ST90 5 Crossed Bugles 6x-EMS	667	1	32.47 32.47	.00 0.00	32.47 32.47	03/20/2026		24350

Bank Number: 1 / Name: First Federal / Description: Operating Account

Payment Number	Type	ID	Name	SRC	Num INV	Gross Amount	Discounts	Net Pay	Payment Date	HP Void	Batch
1940	EPAY	A	FIRST FEDERAL BANK OF FLORIDA- ST90 Copy Paper 4x-EMS	667	1	113.12 113.12	.00 0.00	113.12 113.12	03/20/2026		24350
1941	EPAY	A	FIRST FEDERAL BANK OF FLORIDA- UT1 BALL SHUTOFFX2;NZZL T-Fire	667	1	2,331.00 2,331.00	.00 0.00	2,331.00 2,331.00	03/20/2026		24350
1942	EPAY	A	FIRST FEDERAL BANK OF FLORIDA- Creamer Pods-Clerk	667	1	39.20 39.20	.00 0.00	39.20 39.20	03/20/2026		24350
1943	EPAY	A	FIRST FEDERAL BANK OF FLORIDA- 2026 Prime Membership	667	1	129.00 129.00	.00 0.00	129.00 129.00	03/20/2026		24350
1944	EPAY	A	FIRST FEDERAL BANK OF FLORIDA- Postcards 250x-Adm	667	1	74.69 74.69	.00 0.00	74.69 74.69	03/20/2026		24350
1945	EPAY	A	FIRST FEDERAL BANK OF FLORIDA- Office Chair-DevOp	667	1	269.99 269.99	.00 0.00	269.99 269.99	03/20/2026		24350
1946	EPAY	A	FIRST FEDERAL BANK OF FLORIDA- Library Books 6x-StAid	667	1	71.22 71.22	.00 0.00	71.22 71.22	03/20/2026		24350
1947	EPAY	A	FIRST FEDERAL BANK OF FLORIDA- Chair Mat-Adm	667	1	31.30 31.30	.00 0.00	31.30 31.30	03/20/2026		24350
1948	EPAY	A	FIRST FEDERAL BANK OF FLORIDA- Disinfectant Cleaner 4pk-Adm	667	1	72.95 72.95	.00 0.00	72.95 72.95	03/20/2026		24350
1949	EPAY	A	FIRST FEDERAL BANK OF FLORIDA- Masking Tape/Dogging Key-Ag	667	1	48.04 48.04	.00 0.00	48.04 48.04	03/20/2026		24350
1950	EPAY	A	FIRST FEDERAL BANK OF FLORIDA- Black Ink Cartridge-PA	667	1	157.02 157.02	.00 0.00	157.02 157.02	03/20/2026		24350
1951	EPAY	A	FIRST FEDERAL BANK OF FLORIDA- Black Ink Cartridge-PA	667	1	225.89 225.89	.00 0.00	225.89 225.89	03/20/2026		24350
1952	EPAY	A	FIRST FEDERAL BANK OF FLORIDA- Name Plate-Adm	667	1	18.00 18.00	.00 0.00	18.00 18.00	03/20/2026		24350
1953	EPAY	A	FIRST FEDERAL BANK OF FLORIDA- Business Cards 1000x-Adm	667	1	64.98 64.98	.00 0.00	64.98 64.98	03/20/2026		24350
1954	EPAY	A	FIRST FEDERAL BANK OF FLORIDA- 2025 TDC marketing/Discounts/W	667	1	750.00 750.00	.00 0.00	750.00 750.00	03/20/2026		24350
1955	EPAY	A	FIRST FEDERAL BANK OF FLORIDA- Tape Meas Keychain 120pcs-CD	667	1	74.90 74.90	.00 0.00	74.90 74.90	03/20/2026		24350
1956	EPAY	A	FIRST FEDERAL BANK OF FLORIDA- AC Director Wanted Posting	667	1	85.09 85.09	.00 0.00	85.09 85.09	03/20/2026		24350
1957	EPAY	A	FIRST FEDERAL BANK OF FLORIDA- Cotton/Crdstk/Bags/Tape-StAid	667	1	46.44 46.44	.00 0.00	46.44 46.44	03/20/2026		24350
1958	EPAY	A	FIRST FEDERAL BANK OF FLORIDA- FL Notary Renew-CD	667	1	275.36 275.36	.00 0.00	275.36 275.36	03/20/2026		24350

Bank Number: 1 / Name: First Federal / Description: Operating Account

Payment Number	Type	ID	Name	SRC	Num INV	Gross Amount	Discounts	Net Pay	Payment Date	HP Void	Batch
1959	EPAY	A	FIRST FEDERAL BANK OF FLORIDA- Membership-CD	667	1	140.00 140.00	.00 0.00	140.00 140.00	03/20/2026		24350
1960	EPAY	A	FIRST FEDERAL BANK OF FLORIDA- Foam board/Keyboard/Cutlery-CD	667	1	38.55 38.55	.00 0.00	38.55 38.55	03/20/2026		24350
1961	EPAY	A	FIRST FEDERAL BANK OF FLORIDA- Wiper Blades 10pk/Stock-Rd	667	1	41.68 41.68	.00 0.00	41.68 41.68	03/20/2026		24350
1962	EPAY	A	FIRST FEDERAL BANK OF FLORIDA- Wiper Blades 10pk/Stock-Rd	667	1	41.65 41.65	.00 0.00	41.65 41.65	03/20/2026		24350
1963	EPAY	A	FIRST FEDERAL BANK OF FLORIDA- Disconnect Switch 8x-Rd	667	1	81.92 81.92	.00 0.00	81.92 81.92	03/20/2026		24350
1964	EPAY	A	FIRST FEDERAL BANK OF FLORIDA- Paper Towels 30pk 4x-Rd	667	1	172.52 172.52	.00 0.00	172.52 172.52	03/20/2026		24350
1965	EPAY	A	FIRST FEDERAL BANK OF FLORIDA- #9747 Car Charger Adapter 2-Rd	667	1	49.58 49.58	.00 0.00	49.58 49.58	03/20/2026		24350
1966	EPAY	A	FIRST FEDERAL BANK OF FLORIDA- #9747 Strobe Light 2x-Rd	667	1	71.98 71.98	.00 0.00	71.98 71.98	03/20/2026		24350
1967	EPAY	A	FIRST FEDERAL BANK OF FLORIDA- #9747 Advisor Light Bar 2x-Rd	667	1	99.98 99.98	.00 0.00	99.98 99.98	03/20/2026		24350
1968	EPAY	A	FIRST FEDERAL BANK OF FLORIDA- Paper/Clamps/Stickers-StAid	667	1	21.55 21.55	.00 0.00	21.55 21.55	03/20/2026		24350
1969	EPAY	A	FIRST FEDERAL BANK OF FLORIDA- Drop Light 2x/Door Button-Rd	667	1	82.87 82.87	.00 0.00	82.87 82.87	03/20/2026		24350
1970	EPAY	A	FIRST FEDERAL BANK OF FLORIDA- Tire Repair Patch Tools-Rd	667	1	66.49 66.49	.00 0.00	66.49 66.49	03/20/2026		24350
1971	EPAY	A	FIRST FEDERAL BANK OF FLORIDA- 26 CVSOA Registration-VS	667	1	350.00 350.00	.00 0.00	350.00 350.00	03/20/2026		24350
1972	EPAY	A	FIRST FEDERAL BANK OF FLORIDA- Clean Out Added Septic S-Shoal	667	1	57.45 57.45	.00 0.00	57.45 57.45	03/20/2026		24350
1973	EPAY	A	FIRST FEDERAL BANK OF FLORIDA- Organizer/Tag Screws-Rd	667	1	22.66 22.66	.00 0.00	22.66 22.66	03/20/2026		24350
1974	EPAY	A	FIRST FEDERAL BANK OF FLORIDA- Spreader Shoulder-Rd	667	1	39.99 39.99	.00 0.00	39.99 39.99	03/20/2026		24350
1975	EPAY	A	FIRST FEDERAL BANK OF FLORIDA- #9747 Radio Bracket Mount-Rd	667	1	67.59 67.59	.00 0.00	67.59 67.59	03/20/2026		24350
1976	EPAY	A	FIRST FEDERAL BANK OF FLORIDA- ST50 Trailer Wash Return-Fire	667	1	76.82- 76.82-	.00 0.00	76.82- 76.82-	03/20/2026		24350
1977	EPAY	A	FIRST FEDERAL BANK OF FLORIDA- ST70 Pine Sol Return-Fire	667	1	40.98- 40.98-	.00 0.00	40.98- 40.98-	03/20/2026		24350

Bank Number: 1 / Name: First Federal / Description: Operating Account

Payment Number	Type	ID	Name	SRC	Num INV	Gross Amount	Discounts	Net Pay	Payment Date	HP Void	Batch
1978	EPAY	A	FIRST FEDERAL BANK OF FLORIDA- ST90 Coffee Pods 32ct 4x-EMS	667 MAR26.69	1	64.00 64.00	.00 0.00	64.00 64.00	03/20/2026		24350
1979	EPAY	A	FIRST FEDERAL BANK OF FLORIDA- Library Book-StAid	667 MAR26.7	1	28.27 28.27	.00 0.00	28.27 28.27	03/20/2026		24350
1980	EPAY	A	FIRST FEDERAL BANK OF FLORIDA- Guide to Chemical Hazards-EMS	667 MAR26.70	1	170.40 170.40	.00 0.00	170.40 170.40	03/20/2026		24350
1981	EPAY	A	FIRST FEDERAL BANK OF FLORIDA- LT Test 3-Ring Binder 6pk-EMS	667 MAR26.71	1	116.40 116.40	.00 0.00	116.40 116.40	03/20/2026		24350
1982	EPAY	A	FIRST FEDERAL BANK OF FLORIDA- UT1 Multi-Batt Overmold C-Fire	667 MAR26.72	1	53.99 53.99	.00 0.00	53.99 53.99	03/20/2026		24350
1983	EPAY	A	FIRST FEDERAL BANK OF FLORIDA- ST70 Pine Sol 2pk 2x-Fire	667 MAR26.73	1	40.98 40.98	.00 0.00	40.98 40.98	03/20/2026		24350
1984	EPAY	A	FIRST FEDERAL BANK OF FLORIDA- ST70 Paper Towels 12pk-Fire	667 MAR26.74	1	32.46 32.46	.00 0.00	32.46 32.46	03/20/2026		24350
1985	EPAY	A	FIRST FEDERAL BANK OF FLORIDA- ST70 Oxy Cleaner 12pk-Fire	667 MAR26.75	1	37.82 37.82	.00 0.00	37.82 37.82	03/20/2026		24350
1986	EPAY	A	FIRST FEDERAL BANK OF FLORIDA- R70 3D Printer Filament 2x-EMS	667 MAR26.76	1	40.70 40.70	.00 0.00	40.70 40.70	03/20/2026		24350
1987	EPAY	A	FIRST FEDERAL BANK OF FLORIDA- ST90 Ladder-EMS	667 MAR26.77	1	340.19 340.19	.00 0.00	340.19 340.19	03/20/2026		24350
1988	EPAY	A	FIRST FEDERAL BANK OF FLORIDA- ST90 Napkins-EMS	667 MAR26.78	1	21.77 21.77	.00 0.00	21.77 21.77	03/20/2026		24350
1989	EPAY	A	FIRST FEDERAL BANK OF FLORIDA- ST90 Disp Forks-EMS	667 MAR26.79	1	20.79 20.79	.00 0.00	20.79 20.79	03/20/2026		24350
1990	EPAY	A	FIRST FEDERAL BANK OF FLORIDA- Air Freshener 9x-Lib	667 MAR26.8	1	8.73 8.73	.00 0.00	8.73 8.73	03/20/2026		24350
1991	EPAY	A	FIRST FEDERAL BANK OF FLORIDA- ST90,50,70 External Speakers ST90,50,70 External Speakers	667 MAR26.80 MAR26.80	2	282.50 282.50 282.50	.00 0.00 0.00	282.50 84.75 197.75	03/20/2026		24350
1992	EPAY	A	FIRST FEDERAL BANK OF FLORIDA- ST90 Storage Cabinet 2x-EMS	667 MAR26.81	1	287.10 287.10	.00 0.00	287.10 287.10	03/20/2026		24350
1993	EPAY	A	FIRST FEDERAL BANK OF FLORIDA- ST90 Disp Cups 50ct 4x-EMS	667 MAR26.82	1	18.72 18.72	.00 0.00	18.72 18.72	03/20/2026		24350
1994	EPAY	A	FIRST FEDERAL BANK OF FLORIDA- ST90 Take Out Containers-EMS	667 MAR26.83	1	49.44 49.44	.00 0.00	49.44 49.44	03/20/2026		24350
1995	EPAY	A	FIRST FEDERAL BANK OF FLORIDA- ST90 Trash Bags 2x-EMS	667 MAR26.84	1	29.95 29.95	.00 0.00	29.95 29.95	03/20/2026		24350
1996	EPAY	A	FIRST FEDERAL BANK OF FLORIDA-	667	2	26.01	.00	26.01	03/20/2026		24350

Bank Number: 1 / Name: First Federal / Description: Operating Account

Payment Number	Type	ID	Name	SRC	Num INV	Gross Amount	Discounts	Net Pay	Payment Date	HP Void	Batch
			B70 Batt Chrgr/R70 Rvt Clips	MAR26.85		26.01	0.00	7.64			
			B70 Batt Chrgr/R70 Rvt Clips	MAR26.85		26.01	0.00	18.37			
1997	EPAY	A	FIRST FEDERAL BANK OF FLORIDA-	667	1	71.79	.00	71.79	03/20/2026		24350
			24.76Gal Fuel-Maint	MAR26.86		71.79	0.00	71.79			
1998	EPAY	A	FIRST FEDERAL BANK OF FLORIDA-	667	2	234.58	.00	234.58	03/20/2026		24350
			UtlAir Hose/Swvl/Plat-Fire,EMS	MAR26.87		234.58	0.00	161.19			
			UtlAir Hose/Swvl/Plat-Fire,EMS	MAR26.87		234.58	0.00	73.39			
1999	EPAY	A	FIRST FEDERAL BANK OF FLORIDA-	667	2	639.00	.00	639.00	03/20/2026		24350
			SMARTFILL ANNUAL REPORTING -EM	MAR26.88		639.00	0.00	319.50			
			SMARTFILL ANNUAL REPORTING -EM	MAR26.88		639.00	0.00	319.50			
2000	EPAY	A	FIRST FEDERAL BANK OF FLORIDA-	667	1	722.22	.00	722.22	03/20/2026		24350
			Workstation chairs for staff 3	MAR26.9		722.22	0.00	722.22			
2001	EPAY	A	NATIONWIDE RETIREMENT SOLUTION	311	1	100.00	.00	100.00	03/20/2026		24361
			PEBSCO/NATIONWIDE 3/20	PR168-142		100.00	0.00	100.00			
989225	CHK	A	ARROWHEAD DBA THE STORE	978	1	46.55	.00	46.55	03/24/2026		24371
			1GAL MO FOAM-RD	12488		46.55	0.00	46.55			
989226	CHK	A	BAKER BUSINESS CENTER LLC	2102	1	17.50	.00	17.50	03/24/2026		24371
			AED Mailed for Repair 2x-EMS	57544		17.50	0.00	17.50			
989227	CHK	A	CARL J ALTMILLER	1104	3	500.00	.00	500.00	03/24/2026		24371
			Fire Run 2.25	FEB2025		200.00	0.00	200.00			
			Fire Run 3.24	MARCH24		100.00	0.00	100.00			
			Fire Run 10.24	OCT24		200.00	0.00	200.00			
989228	CHK	A	CHRIS BONDS	1148	1	50.00	.00	50.00	03/24/2026		24371
			Fire Run 1.22	JAN22		50.00	0.00	50.00			
989229	CHK	A	CITY ELECTRIC SUPPLY	2084	1	387.79	.00	387.79	03/24/2026		24371
			Bulbs 13x/Knabb-Rec	195910		387.79	0.00	387.79			
989230	CHK	A	CITY OF MACCLENNY	109	5	353.96	.00	353.96	03/24/2026		24371
			339 E MACCLENNY AVE-COURTHOUSE	#500836-167		94.18	0.00	94.18			
			360 E SHUEY-BLDG WATER	#500976-167		66.82	0.00	66.82			
			TRI CNTY/GAL COURT SERVICES	#500977-167		61.18	0.00	61.18			
			55 N 3RD ST-ADMIN	#500987-167		69.82	0.00	69.82			
			3RD ST-PUBLIC DEFENDER	#500996-167		61.96	0.00	61.96			
989231	CHK	A	CLAY ELECTRIC CORPORATION INC	110	5	240.85	.00	240.85	03/24/2026		24371
			JONESVILLE/BLDG REC LIGHTS	#1078757-167		16.07	0.00	16.07			
			MARGARETTA PARK ST LGHT/HWY127	#2815405-167		42.31	0.00	42.31			
			MARGARETTA PARK POWER POLE	#6049084-167		42.19	0.00	42.19			
			MUDLAKE RECYCLE SITE	#791020-167		91.91	0.00	91.91			
			JONESVILLE PARK/9575CR	#8958124-167		48.37	0.00	48.37			
989232	CHK	A	DARRELL CREWS SEPTIC TANK SERV	528	1	350.00	.00	350.00	03/24/2026		24371
			ST70 Septic Pump Out-Fire	61741		350.00	0.00	350.00			
989233	CHK	A	DUVAL FORD	165	1	717.74	.00	717.74	03/24/2026		24371
			FR2 Diagnostic-Fire	6437881		717.74	0.00	717.74			

Bank Number: 1 / Name: First Federal / Description: Operating Account

Payment Number	Type	ID	Name	SRC	Num INV	Gross Amount	Discounts	Net Pay	Payment Date	HP Void	Batch
989234	CHK	A	EMS CONSULTANTS LTD-ELEVOS JANUARY 2026 BILLING SVCS	1146 5280	1	3,166.94 3,166.94	.00 0.00	3,166.94 3,166.94	03/24/2026		24371
989235	CHK	A	FAE4HA TREASURER FAE4-HA FY21/22 Membership	282 2021-14	1	140.00 140.00	.00 0.00	140.00 140.00	03/24/2026		24371
989236	CHK	A	FPL 07521-58113 WOMEN SOFTBALL 12567-18154 STREET LIGHTS 12567-18154 STREET LIGHTS 12567-18154 STREET LIGHTS 17019-59270 S50 GLEN FIRE 17074-19774 PUBLIC DEFENDER 47253-66092 COURTHOUSE 50483-97334 TRANSP/WILLIS HODG 55706-76238 SENIOR LIFE CTR 58599-18764 JEFF STARLING-SW 65342-69524 ST50 SIGN 80842-28439 SOFTBALL 480 6TH 85105-19757 ADMIN BLDG 3RD ST 85115-17784 CRT SERV/GAL 85125-13709 COM DEV 360E SHUEY 85215-10746 COA US90 85255-19743 COA US90 85265-17779 LIBRARY 14 E MCIVE 85285-11721 OLD JAIL 42W MCIVE 90088-52551 OLUSTEE PARK LED	200 07521-58113.1-132 12567-18154-087 12567-18154-087 12567-18154-087 17019-59270-127 17074-19774.1-132 47253-66092.1-132 50483-97334.1-132 55706-76238-048 58599-18764.1-132 65342-69524.1-132 80842-28439.1-132 85105-19757.1-132 85115-17784.1-132 85125-13709.1-132 85215-10746.1-132 85255-19743.1-132 85265-17779.1-132 85285-11721.1-132 90088-52551.1-132	20	12,346.21 182.26 95.55 95.55 95.55 81.92 186.82 5,881.64 2,282.62 715.86 56.98 36.11 135.70 410.32 493.73 264.21 353.53 32.57 912.67 160.42 63.30	.00 0.00 0.00 0.00 0.00 0.00 0.00 0.00 0.00 0.00 0.00 0.00 0.00 0.00 0.00 0.00 0.00 0.00 0.00 0.00 0.00 0.00 0.00	12,346.21 182.26 11.94 71.66 11.95 81.92 186.82 5,881.64 2,282.62 715.86 56.98 36.11 135.70 410.32 493.73 264.21 353.53 32.57 912.67 160.42 63.30	03/24/2026		24371
989237	CHK	A	GLEN CASH STORE INC 6ft Chain/Grab Hook 2x-Rd	212 B40847	1	35.32 35.32	.00 0.00	35.32 35.32	03/24/2026		24371
989238	CHK	A	GRANT BARKER M.D Medical Director Feb26	4615 2026-2	1	3,000.00 3,000.00	.00 0.00	3,000.00 3,000.00	03/24/2026		24371
989239	CHK	A	GUERRY FUNERAL HOME ME Transport 8/4/23	218 AUG4.23	1	410.00 410.00	.00 0.00	410.00 410.00	03/24/2026		24371
989240	CHK	A	HAGAN ACE HARDWARE OF MACCLENN Pipe Ctr/Elbw/Cpl/Primer/H-Rec Screws/Shop-Rec Tie Down Ratchet 4pk-Rec Wire Rope/King Ruise Prk-Rec Garden Hose-Rec Primer Cmnt/Cap/PVC Cutt-Shoal PVC/Elbw/Hose/Hacksaw-Rec Ext Cord/Tapcube-Shoals 5Gal Bucket/Pickup Tool-Rec Self Drill Screws-Rec Fltr/Gloves/Bckt/Cloth/Sp-Hist Bckt/Plaster/Patch/Screws-Hist Disp Gloves/Water 24pk 2x-Main Sand Paper Set/Osc Blade-Hist Gloves/Flagging Tape 2x-Rec Lubricant Oil-Main Felt Pads/Clear Pads 2x-CD UT1 Truefuel/Tie Plate/Sc-Fire	221 356571 356690 356758 356930 356996 357010 357027 357153 357247 357276 357315 357392 357420 357431 357435 357439 357506 357573	18	769.37 60.21 7.35 32.99 4.59 20.23 38.49 40.10 48.74 73.36 13.33 173.85 72.52 42.33 44.14 31.43 13.79 13.03 38.89	.00 0.00 0.00 0.00 0.00 0.00 0.00 0.00 0.00 0.00 0.00 0.00 0.00 0.00 0.00 0.00 0.00 0.00 0.00	769.37 60.21 7.35 32.99 4.59 20.23 38.49 40.10 48.74 73.36 13.33 173.85 72.52 42.33 44.14 31.43 13.79 13.03 38.89	03/24/2026		24371

Bank Number: 1 / Name: First Federal / Description: Operating Account

Payment Number	Type	ID	Name	SRC	Num INV	Gross Amount	Discounts	Net Pay	Payment Date	HP Void	Batch
989241	CHK	A	HAMILTON MEDICAL, INC Valved Tee Adapter-EMS	4588 23464842	1	210.00 210.00	.00 0.00	210.00 210.00	03/24/2026		24371
989242	CHK	A	HENRY SCHEIN INC Metrix Kit/Lancet/Gsct/Glo-EMS	588 53619972	1	660.36 660.36	.00 0.00	660.36 660.36	03/24/2026		24371
989243	CHK	A	JASON GRUNTZEL Fire Run 10.23	4466 OCT23	1	200.00 200.00	.00 0.00	200.00 200.00	03/24/2026		24371
989244	CHK	A	JIMMY'S AUTOMOTIVE REPAIR INC #49 Oil Change-Rec #47 Oil Change-Rec T30 Tires/Install-Fire #88 Tires 4x-Maint	1105 23071 23088 23146 23167	4	1,495.86 93.94 91.92 846.00 464.00	.00 0.00 0.00 0.00 0.00	1,495.86 93.94 91.92 846.00 464.00	03/24/2026		24371
989245	CHK	A	L V HIERS INC 148Gal Fuel-EMS 195 GA DYED DIESEL-EMS	267 493122 493123	2	1,064.00 430.24 633.76	.00 0.00 0.00	1,064.00 430.24 633.76	03/24/2026		24371
989246	CHK	A	MACCLENNY MOWER AND SAW INC Chainsaw Chain 2x-Rec Weedeater Two Cycle Oil 6x-Rec Pulley/Wing Nut/Air Filter-Rec Mower Blades 2x-Rd Mower Blades 9x-Rec Mower Blades 9x-Rec Chain 2x-Rd BR50 Fuel Pump-Fire Gallon Container/Blade-Beck 1Qt Premix Fuel 6x-Beck Gallon Container 2x-Beck Gallon Container 2x-Beck Blade/Deck Belt/Filter-Main Blade/Fuel Filter/Bolt-Rec Mower PTO Clutch-Rec Mower Driveshaft/Belt Pump-Rec 1Gal 2Cycle Premix Fuel-Beck Chainsaw-Rec	1334 118470 118488 118824 119316 119390 120037 120061 13891 13963 14024 14087 14135 14160 14759 14889 14918 15060 8097	18	3,136.57 43.30 23.04 108.99 58.98 162.00 135.00 40.70 26.73 68.82 47.94 59.98 59.98 485.84 202.95 414.27 379.89 28.17 789.99	.00 0.00 0.00 0.00 0.00 0.00 0.00 0.00 0.00 0.00 0.00 0.00 0.00 0.00 0.00 0.00 0.00 0.00 0.00 0.00	3,136.57 43.30 23.04 108.99 58.98 162.00 135.00 40.70 26.73 68.82 47.94 59.98 59.98 485.84 202.95 414.27 379.89 28.17 789.99	03/24/2026		24371
989247	CHK	A	NAPA AUTO PARTS- JAX015 #99 Oil/Air Filter-Rd Gloves/Gauge/Chuck/Shop-Rd T40 Coupling 7x/Adapter-Fire T40 Coupling/Air Brake Ho-Fire #99 Wiper Blade/Soap-Rd Welding Wire/Shop-Rd Gloves/Lubricant-Rd Threadlock/Silicone/Shop-Rd #156 Clamp 12x/Battery-Rd #99 Spark Plug Boot/Plug-Rd #758 Adptr/Fittings/Hose/Ch-Rd #2806 Fuel Filter 5x-Rd #110 Hose Fittings/Hose-Rd Utility Gloves 3pk-Rd #97 Fuel/Oil Filter-Rd air compressor for #99/rd inv	284 000053 000054 000074 000086 000134 000256 000340 000365 000397 000406 000408 000445 000488 000489 000541 000543	124	13,738.95 31.98 73.47 80.62 22.78 29.37 39.99 49.48 40.28 241.29 183.76 305.36 124.58 246.69 10.99 81.35 3,000.00	.00 0.00 0.00 0.00 0.00 0.00 0.00 0.00 0.00 0.00 0.00 0.00 0.00 0.00 0.00 0.00 0.00	13,738.95 31.98 73.47 80.62 22.78 29.37 39.99 49.48 40.28 241.29 183.76 305.36 124.58 246.69 10.99 81.35 3,000.00	03/24/2026		24371

Bank Number: 1 / Name: First Federal / Description: Operating Account

Payment Number	Type	ID	Name	SRC	Num INV	Gross Amount	Discounts	Net Pay	Payment Date	HP Void	Batch
			GMC Sierra Brk Shoe/Disc Pa-Rd	000651		126.64	0.00	126.64			
			Utility Gloves 3pk/Gloves-Rd	000652		25.98	0.00	25.98			
			#321 Hose/Fittings/Oring-Rd	000691		271.92	0.00	271.92			
			GMC Sierra Brake Rotor/Shoe-Rd	000764		118.09	0.00	118.09			
			6Ton Jack Stands/Sockets-Rd	000765		137.98	0.00	137.98			
			#99 Bed Liner 2x-Rd	000766		140.98	0.00	140.98			
			#97 Fuel Treatment-Rd	000838		14.29	0.00	14.29			
			#97 Fuel Filter-Rd	000839		28.54	0.00	28.54			
			Ratchet/Hexbit/Socket-Rd	000847		107.47	0.00	107.47			
			#806 Batt Cbl Lug/Solenoid-Rd	000910		21.52	0.00	21.52			
			UT1 Fuel Cap-Fire	000947		31.99	0.00	31.99			
			Adapter/Tire Shop-Rd	000953		18.49	0.00	18.49			
			#347 Battery/Battery Box-Rd	000965		198.59	0.00	198.59			
			#805 Alternator-Rd	000985		159.95	0.00	159.95			
			#2702 2.5 DEF-Rd	001161		38.98	0.00	38.98			
			#99 Adptr/Connector/Coupler-Rd	001164		136.50	0.00	136.50			
			HQ Silicone/Towels/Brush-EMS	001287		45.94	0.00	45.94			
			Antifreeze-AC	001326		10.06	0.00	10.06			
			Bat2 Capsule-Fire	001753		16.99	0.00	16.99			
			E20 Fittings/Hose/Adapter-Fire	001856		75.27	0.00	75.27			
			T30 Wiper Motor-Fire	10522		134.03	0.00	134.03			
			E70 Solenoid-Fire	10669		67.99	0.00	67.99			
			UT1 Silicone/Terry Towels-Fire	10670		36.27	0.00	36.27			
			Cleaning Wipes/Brake Flui-Main	11374		24.98	0.00	24.98			
			UT1 Bulb 2x-Fire	11785		4.58	0.00	4.58			
			UT1 Super Glue-Fire	11786		3.29	0.00	3.29			
			#8375 Hose Fittings/Hose-SW	1188		88.59	0.00	88.59			
			GMC Sierra Wiper Blade 2x-Rd	1189		19.38	0.00	19.38			
			UT1 2.5 DEF/Bug Clnr/Funn-Fire	12188		48.25	0.00	48.25			
			Transmission Fluid/Shop 3x-Rd	1283		119.97	0.00	119.97			
			#5753 Oil Filter 2x-Rd	1484		15.98	0.00	15.98			
			Lamp Gasket/Gloves/Shop-Rd	1485		52.81	0.00	52.81			
			#99 Hose/Batt Cable/Cbl Lug-Rd	1544		105.71	0.00	105.71			
			#79 Headlight Bulb-Rec	15759		9.39	0.00	9.39			
			#224 Brake Pads/Rotors-AC	15929		472.94	0.00	472.94			
			#5753 Oil Fil 5x/Air Fil 3x-Rd	16148		137.61	0.00	137.61			
			#5753 Oil Fil/Air Fil Retur-Rd	16184		37.99	0.00	37.99			
			Tax Refund 16148-Rd	16262		9.00	0.00	9.00			
			#960 Hose Fitting 2x/Hose 2-SW	16265		70.30	0.00	70.30			
			Paint Marker/Locknut/Screw-Rd	1864		35.06	0.00	35.06			
			Chuck/Gauge/Gloves-Rd	1977		80.97	0.00	80.97			
			#2806 Fuel Filter/Oil Filte-Rd	1978		81.35	0.00	81.35			
			#156 Tees/Hose/Elbow/Connec-Rd	2029		91.76	0.00	91.76			
			#156 Water Pump-Rd	2078		119.99	0.00	119.99			
			#325 Battery Cable 42x-Rd	2079		185.18	0.00	185.18			
			#325 Chuck/Clamp-Rd	2122		45.48	0.00	45.48			
			E20 Hose Fitting/Hose-Fire	2124		64.94	0.00	64.94			
			#960 Transmission Fluid 3x-SW	2155		75.37	0.00	75.37			
			#943 Hose Fitting/Hose-SW	2163		253.23	0.00	253.23			
			WL1 Fuel Trtmt/Clamp/Filt-Fire	2165		14.47	0.00	14.47			
			#5753/347 Terminals/Chuck-Rd	2288		22.97	0.00	22.97			
			#125 Hose/Fittings/Absorben-SW	2292		228.32	0.00	228.32			
			Hose Fitting/Hose/Seal Tape-SW	23054		122.03	0.00	122.03			
			#943 Hose/Fittings-SW	2340		79.39	0.00	79.39			
			#14 Air Filter-Main	23742		29.71	0.00	29.71			
			Absorbent/Gloves/Coupler/Ch-Rd	2418		84.43	0.00	84.43			

Bank Number: 1 / Name: First Federal / Description: Operating Account

Payment Number	Type	ID	Name	SRC	Num INV	Gross Amount	Discounts	Net Pay	Payment Date	HP Void	Batch
			E50 Tubing 3x/Coupling 4x-Fire	2448		23.31	0.00	23.31			
			Screw/Nut/Lockwash-Shoal	25190		8.87	0.00	8.87			
			#817 Rear Brake Pads-SW	2546		44.32	0.00	44.32			
			#14 Brake Disc/Brake Pad-Main	25840		179.27	0.00	179.27			
			#115 Air Filter/Fuel Treat-Rd	2634		140.03	0.00	140.03			
			#115 Air Filter-Rd	2635		35.65	0.00	35.65			
			#753 Batt Protect/Sealer/Ba-Rd	2676		182.19	0.00	182.19			
			#753 Battery-Rd	2682		37.87	0.00	37.87			
			Battery-Rec	26839		53.08	0.00	53.08			
			SQ51 Thermostat/Antifreez-Fire	2694		31.97	0.00	31.97			
			#753 Fuse 4x-Rd	2699		14.76	0.00	14.76			
			SQ51 Connector 2x-Fire	27013		4.00	0.00	4.00			
			#5753 Battery-Rd	2702		138.12	0.00	138.12			
			#14 Brake Rotor-Main	27179		221.98	0.00	221.98			
			#14 Brake Rotor-Main	27229		3.99	0.00	3.99			
			#14 Brake Pad Return-Main	27239		85.99	0.00	85.99			
			#14 Brake Pad/Brake Clean-Main	27247		185.64	0.00	185.64			
			#817 Brake Disc 2x-SW	27254		128.98	0.00	128.98			
			Wash&Wax/Bleach/Armorall-Rec	27445		38.45	0.00	38.45			
			#102 Oil Filter/Trans Mount-Rd	27493		36.87	0.00	36.87			
			Sndrsn Compactor Fittings/H-SW	27565		307.76	0.00	307.76			
			#803 Battery-Rd	27566		209.49	0.00	209.49			
			#99 Impact Wrench/Adapter 4-Rd	2933		246.95	0.00	246.95			
			#7712 Oil/Air Filt/JB Weld-SW	33857		42.42	0.00	42.42			
			#806 Fuel Filter/Wiper Blad-Rd	33904		48.22	0.00	48.22			
			#102 Ignition Switch/HD Wip-Rd	34024		56.97	0.00	56.97			
			#2806 Capsule/Grease/Elec C-Rd	34046		83.44	0.00	83.44			
			#964 Oil/Adapter/Support-Rd	34075		68.97	0.00	68.97			
			#806 Fuel Filter/Air Filter-Rd	34851		144.20	0.00	144.20			
			#960 Air Chuck/Gauge-SW	34928		57.98	0.00	57.98			
			#49 1Qt 5W30 Oil 2x-Rec	46414		25.98	0.00	25.98			
			E50 Circuit Breaker-Fire	47525		64.99	0.00	64.99			
			#142 Hose 2x/Clamp 20x-SW	5279		48.58	0.00	48.58			
			#90 Fuel Filter 3x-Rd	5679		26.73	0.00	26.73			
			E50 Hood Latch Kit-Fire	6685		58.99	0.00	58.99			
			B30 Starter Button-Fire	6687		15.49	0.00	15.49			
			B30 Solenoid-Fire	6690		16.22	0.00	16.22			
			B30 Fuel Filter-Fire	6691		4.69	0.00	4.69			
			BR70 Air Filter-Fire	9004		25.29	0.00	25.29			
			E50 Air Filter 4x-Fire	9005		96.60	0.00	96.60			
			T40 Wiper Motor-Fire	9173		134.03	0.00	134.03			
			#953 Battery 2x-Rd	9213		478.98	0.00	478.98			
			#817 Front Brake Pads-SW	9240		44.32	0.00	44.32			
			#964 Front Brake Pads-Rd	9292		35.40	0.00	35.40			
			#156 Wiper Blade 4x/Tune Up-Rd	9294		60.45	0.00	60.45			
			#960 Env Hose/Hyd Hose-SW	9434		141.50	0.00	141.50			
			Plasma Cutter Rpr-Rd	999810		90.86	0.00	90.86			
			Battery Charger/Shop-Rd	999887		63.99	0.00	63.99			
			#321 Apdtr/Fittings/Hose-Rd	999888		221.29	0.00	221.29			
			#5753 Mini Bulbs/Coupler-Rd	999918		10.78	0.00	10.78			
			#99 Coveralls/Welding Helme-Rd	999920		27.58	0.00	27.58			
			#960 Grommet/Signal Light-Rd	999973		70.56	0.00	70.56			
989248	CHK	A	NEW RIVER SOLID WASTE ASSOCIAT	317	1	45.58	.00	45.58	03/24/2026		24371
			Animal Waste 2.26	FEB26AC		45.58	0.00	45.58			

Bank Number: 1 / Name: First Federal / Description: Operating Account

Payment Number	Type	ID	Name	SRC	Num INV	Gross Amount	Discounts	Net Pay	Payment Date	HP Void	Batch
989249	CHK	A	PENGUIN MANAGEMENT INC	1162	2	2,604.00	.00	2,604.00	03/24/2026		24371
			DEVELOPMENT;RECIPIENT PLAN;5 A	17082		2,604.00	0.00	1,302.00			
			DEVELOPMENT;RECIPIENT PLAN;5 A	17082		2,604.00	0.00	1,302.00			
989250	CHK	A	ROBERT'S OXYGEN COMPANY INC	4306	2	427.19	.00	427.19	03/24/2026		24371
			Oxygen Tank 3x-EMS	210339		148.09	0.00	148.09			
			Oxygen Tank Rental 19x-EMS	G47407		279.10	0.00	279.10			
989251	CHK	A	SARGENT SEAT COVER CO., INC	4648	1	1,996.73	.00	1,996.73	03/24/2026		24371
			R50 REUPHOLSTER FRONT SEAT-EMS	24685		1,996.73	0.00	1,996.73			
989252	CHK	A	SCOTTY RHODEN, SHERIFF	757	1	200,252.45	.00	200,252.45	03/24/2026		24371
			Inmate Medical FY23/24	3452		200,252.45	0.00	200,252.45			
989253	CHK	A	SHERWIN-WILLIAMS COMPANY	1245	1	38.44	.00	38.44	03/24/2026		24371
			1Gal Paint SW6101-SOE	7191-2		38.44	0.00	38.44			
989254	CHK	A	SMARTCOP	1065	2	453.00	.00	453.00	03/24/2026		24371
			2026 CAD Maint 5.26-4.27	1155		453.00	0.00	226.50			
			2026 CAD Maint 5.26-4.27	1155		453.00	0.00	226.50			
989255	CHK	A	SOUTHERN AIR & REFRIGERATION,	614	2	445.00	.00	445.00	03/24/2026		24371
			ST90 AC Capacitor-EMS	5672		200.00	0.00	200.00			
			ST90 Srvc Call/Refrigerant-EMS	5869		245.00	0.00	245.00			
989256	CHK	A	SOUTHERN DIESEL & AUTO	746	2	2,762.84	.00	2,762.84	03/24/2026		24371
			UT1 OIL CHANGE,FILTER,CAP-FIRE	4502		1,087.00	0.00	1,087.00			
			UT11 EGR COOLER ASSEMBLY-Fire	4575		1,675.84	0.00	1,675.84			
989257	CHK	A	TAMPA ELECTRIC COMPANY DBA PEO	4510	1	153.59	.00	153.59	03/24/2026		24371
			SENIOR LIFE NATURAL GAS 3.26	8.25-013		153.59	0.00	153.59			
989258	CHK	A	THOMAS C FINK	2192	1	233.72	.00	233.72	03/24/2026		24371
			Fire Run 11.21	FIRERUN11.21		233.72	0.00	233.72			
989259	CHK	A	WINDMILL CONSULTING	1081	1	3,047.15	.00	3,047.15	03/24/2026		24371
			Interim Director 9.22-CD	OCT17.22		3,047.15	0.00	3,047.15			
989260	CHK	A	ARRIVE	1047	1	108.00	.00	108.00	03/26/2026		24406
			Shoals Kiosk Check 2.26	4821		108.00	0.00	108.00			
989261	CHK	A	BAKER COUNTY PRESS	56	2	124.14	.00	124.14	03/26/2026		24406
			BID2026-01 Lawn Service Ad	78053		83.44	0.00	83.44			
			LPA Meeting Date Change Ad	78054		40.70	0.00	40.70			
989262	CHK	A	CFX OFFICE TECHNOLOGY INC	1185	1	297.85	.00	297.85	03/26/2026		24406
			J12094 3.26-EMS	346970		297.85	0.00	297.85			
989263	CHK	A	GLEN CASH STORE INC	212	1	46.98	.00	46.98	03/26/2026		24406
			Press Gauge/Press Switch-Main	A237397		46.98	0.00	46.98			
989264	CHK	A	HAGAN ACE HARDWARE OF MACCLENN	221	5	217.26	.00	217.26	03/26/2026		24406
			Wipes/Brush Cup/Brus-Main,Hist	357530		47.68	0.00	47.68			
			Faucet/Nipple/Trash Ba-CH,Main	357554		116.54	0.00	116.54			
			4.5Gal Drywall Mud Pail-Hist	357599		21.59	0.00	21.59			
			PVC Elbow 4x-Ag	357600		26.96	0.00	26.96			

Bank Number: 1 / Name: First Federal / Description: Operating Account

Payment Number	Type	ID	Name	SRC	Num INV	Gross Amount	Discounts	Net Pay	Payment Date	HP Void	Batch
			#48 Galv Strap Hanger-Main	357601		4.49	0.00	4.49			
989265	CHK	A	KELLY KLEAN	1321	2	4,840.00	.00	4,840.00	03/26/2026		24406
			KELLY KLEAN 3.26	4375		4,840.00	0.00	2,950.00			
			KELLY KLEAN 3.26	4375		4,840.00	0.00	1,890.00			
989266	CHK	A	KNOX PEST CONTROL	2180	15	438.00	.00	438.00	03/26/2026		24406
			HISTORICAL 42 3.26	359551		32.00	0.00	32.00			
			ADMIN PEST 3.26	659548		30.00	0.00	30.00			
			LIB 14W PEST 3.26	659549		30.00	0.00	30.00			
			MAIN 323 PEST 3.26	659553		20.00	0.00	20.00			
			PA/TC/SOE PEST 3.26	659554		45.00	0.00	45.00			
			COM DEV 360 PEST 3.26	659557		30.00	0.00	30.00			
			DEPU DG LN 14564 3.26	659558		35.00	0.00	35.00			
			CRT SERV PEST 3.26	659560		30.00	0.00	30.00			
			TRNSPT 9264 PEST 3.26	659561		34.00	0.00	34.00			
			FIRE10 4980 3.26	659562		18.00	0.00	18.00			
			FIRE20 14496 3.26	659563		18.00	0.00	18.00			
			FIRE40 26461 3.26	659565		18.00	0.00	18.00			
			ST70 12170WIREMIL 3.26	659629		18.00	0.00	18.00			
			COA 5426 PEST 3.26	660037		40.00	0.00	40.00			
			Rodent Control 3.26-AC	660243		40.00	0.00	40.00			
989267	CHK	A	L V HIERS INC	267	15	1,140.40	.00	1,140.40	03/26/2026		24406
			27.60Gal Fuel-Rec	196388		73.58	0.00	73.58			
			27.60Gal Fuel-Rec	196664		82.96	0.00	82.96			
			35Gal Fuel-Rec	196843		108.72	0.00	108.72			
			29.20Gal Fuel-Rec	196852		90.68	0.00	90.68			
			21.80Gal Fuel-Maint	196992		72.08	0.00	72.08			
			22.50Gal Fuel-AC	607178		74.39	0.00	74.39			
			25Gal Fuel-Rec	607951		66.65	0.00	66.65			
			30.40Gal Fuel-Rec	607968		81.08	0.00	81.08			
			30Gal Fuel-Rec	608004		79.98	0.00	79.98			
			27Gal Fuel-Maint	608014		71.99	0.00	71.99			
			5Gal Marine Gas-Rec	608033		15.25	0.00	15.25			
			32Gal Fuel-Rec	608067		94.92	0.00	94.92			
			17.80Gal Fuel-Maint	608085		52.80	0.00	52.80			
			32.80Gal Fuel-Rec	608090		98.60	0.00	98.60			
			24.70Gal Fuel-Maint	608102		76.72	0.00	76.72			
989268	CHK	A	MACCLENNY MOWER AND SAW INC	1334	5	471.39	.00	471.39	03/26/2026		24406
			1Gal 50:1 Fuel Mix 3x-Beck	15712		80.28	0.00	80.28			
			Mower Blades 3x-Rec	15715		54.00	0.00	54.00			
			#2901 Carburetor/Pump-Rd	15722		127.98	0.00	127.98			
			Valve 4x-Rec	15735		102.08	0.00	102.08			
			1Gal 50:1 Fuel Mix 4x-Beck	15771		107.05	0.00	107.05			
989269	CHK	A	NAPA AUTO PARTS- JAX015	284	3	318.15	.00	318.15	03/26/2026		24406
			#4311 Water Pump/Thermos-DevOp	47669		302.98	0.00	302.98			
			Valve Tool-Maint	47686		7.49	0.00	7.49			
			#14 ATC-5 Fuse/ATC-3 Fuse-Main	47702		7.68	0.00	7.68			
989270	CHK	A	QUALITY INTERNET SERVICES OF F	349	4	467.25	.00	467.25	03/26/2026		24406
			ST50 Phone/Internet 4.26	12199		139.35	0.00	139.35			
			Clerk Internet 4.26	12204		168.90	0.00	168.90			
			Internet Service 4.26	12254		159.00	0.00	80.00			

Bank Number: 1 / Name: First Federal / Description: Operating Account

Payment Number	Type	ID	Name	SRC	Num INV	Gross Amount	Discounts	Net Pay	Payment Date	HP Void	Batch
			Internet Service 4.26	12254		159.00	0.00	79.00			
989271	CHK	A	SOUTHEASTERN SERVICES INC	387	1	1,121.92	.00	1,121.92	03/26/2026		24406
			Shoals Gate Attendants 3/8	128889		1,121.92	0.00	1,121.92			
989272	CHK	A	STAPLES ADVANTAGE	2164	5	579.78	.00	579.78	03/26/2026		24406
			Tlt Clnr/Bleach/Rubber Ban-Rec	6057876503		146.65	0.00	146.65			
			Tlt Clnr/Bleach/Rbr Band-Shoal	6057876506		77.35	0.00	77.35			
			Trash Bags 2x-Shoals	6058123889		98.88	0.00	98.88			
			Trash Bags 4x-Rec	6058123890		197.76	0.00	197.76			
			Trash Bags 2x-PD	6058193563		59.14	0.00	59.14			
989273	CHK	A	TARBOX CONSULTING AND DESIGN I	484	3	58,041.88	.00	58,041.88	03/26/2026		24406
			Enterprise East Infrastructure 1740			18,381.00	0.00	18,381.00			
			Enterprise East Infrastructure 1741			26,318.00	0.00	26,318.00			
			Enterprise East Infrastructure 1744			13,342.88	0.00	13,342.88			
989274	CHK	A	ADVANCED TIRE SERVICE, LLC	2372	2	830.02	.00	830.02	03/30/2026		24412
			#2806 2 11R24.5 tires /rd inv	4023389		728.48	0.00	728.48			
			Box Tire Repair Kit 3x-Rd	4023430		101.54	0.00	101.54			
989275	CHK	A	BALER & COMPACTOR HYDRAULIC SE	4419	1	1,368.28	.00	1,368.28	03/30/2026		24412
			cuyler compactor repair-direct	321016		1,368.28	0.00	1,368.28			
989276	CHK	A	BOB'S BARRICADES INC	2174	1	378.20	.00	378.20	03/30/2026		24412
			Barricades 620x-Rd	G965835		378.20	0.00	378.20			
989277	CHK	A	CGC INC	4645	1	503,707.50	.00	503,707.50	03/30/2026		24412
			Willis Hodges drainage improve	C-25-01		503,707.50	0.00	503,707.50			
989278	CHK	A	HAGAN ACE HARDWARE OF MACCLENNY	221	4	854.11	.00	854.11	03/30/2026		24412
			Miltondale Rpr/Screws/Pain-Rd	357504		476.08	0.00	476.08			
			Concrete Mix 56x-Rd	357555		281.68	0.00	281.68			
			Safety Vest 6x-Rd	357575		66.18	0.00	66.18			
			Yellow Pine 2x/Bridge Deck-Rd	357675		30.17	0.00	30.17			
989279	CHK	A	ICE CUBE EXPRESS	75	1	108.00	.00	108.00	03/30/2026		24412
			10lb Bag Ice 80x-Rd	14832		108.00	0.00	108.00			
989280	CHK	A	L V HIERS INC	267	3	9,068.17	.00	9,068.17	03/30/2026		24412
			1840 gals dyed diesel/rd inv 1	196760		7,157.60	0.00	7,157.60			
			223 gals reg gas/rd inv 493024	493024		610.27	0.00	610.27			
			408 gals reg gas/rd inv 493224	493224		1,300.30	0.00	1,300.30			
989281	CHK	A	MACCLENNY MOWER AND SAW INC	1334	2	127.37	.00	127.37	03/30/2026		24412
			SideBySide Fltr/Spk Plg/Oil-Rd	15742		46.88	0.00	46.88			
			Cement Mixer Rental 1 Day-Rd	4552		80.49	0.00	80.49			
989282	CHK	A	MURPHY COMMUNICATIONS INC	305	1	813.00	.00	813.00	03/30/2026		24412
			9747 furnish/install radio-Rd	17677		813.00	0.00	813.00			
989283	CHK	A	NAPA AUTO PARTS- JAX015	284	2	36.97	.00	36.97	03/30/2026		24412
			#313 Posts/Gloves-Rd	47423		26.98	0.00	26.98			
			#313 Posts-Rd	47670		9.99	0.00	9.99			
989284	CHK	A	NEW RIVER SOLID WASTE ASSOCIAT	317	4	4,638.30	.00	4,638.30	03/30/2026		24412

Bank Number: 1 / Name: First Federal / Description: Operating Account

Payment Number	Type	ID	Name	SRC	Num INV	Gross Amount	Discounts	Net Pay	Payment Date	HP Void	Batch
			Feb 2026 bh Tipping /sw	FEB26BH		2,035.50	0.00	2,035.50			
			Citizen Tipping Feb26	FEB26CIT		181.50	0.00	181.50			
			Feb 2026 BC trash pick upTippi	FEB26RES		648.90	0.00	648.90			
			Feb 2026 VJS Tipping /sw	FEB26VJS		1,772.40	0.00	1,772.40			
989285	CHK	A	HRA Reimbursement FY25-26	HRA01FY25-26	4652 1	500.00	.00	500.00	03/30/2026		24412
						500.00	0.00	500.00			
989286	CHK	A	QUALITY INTERNET SERVICES OF F 349		1	9,854.83	.00	9,854.83	03/30/2026		24412
			2nd litter cycle though 3/2/26	150646		9,854.83	0.00	9,854.83			
989287	CHK	A	RING POWER CORPORATION		365 1	862.42	.00	862.42	03/30/2026		24412
			#1211 travel rpr ECM comput-Rd	07WC1315903		862.42	0.00	862.42			
989288	CHK	A	SOUTHEASTERN SERVICES INC		387 1	12,306.06	.00	12,306.06	03/30/2026		24412
			site attendants thr 2/22/26	128884		12,306.06	0.00	12,306.06			
989289	CHK	A	TARBOX CONSULTING AND DESIGN I		484 1	1,237.50	.00	1,237.50	03/30/2026		24412
			CEI through 2/28/2026 Willis H	1755		1,237.50	0.00	1,237.50			
989290	CHK	A	ADVANCE AUTO PARTS AKA-AAP FIN		951 1	19.98	.00	19.98	03/31/2026		24427
			E10 Wiper Blade 2x-Fire	0801		19.98	0.00	19.98			
989291	CHK	A	AIRGAS USA, LLC		1218 1	502.80	.00	502.80	03/31/2026		24427
			Feb 2026 cylinder rental/rd in	5523085739		502.80	0.00	502.80			
989292	CHK	A	BAKER BUSINESS CENTER LLC		2102 1	33.09	.00	33.09	03/31/2026		24427
			UT1 Parts Mailed-Fire	112955		33.09	0.00	33.09			
989293	CHK	A	BENNETT FIRE PRODUCTS CO INC		2329 1	28,007.92	.00	28,007.92	03/31/2026		24427
			7SETS GLOBE JACKETS,T-Fire,EMS	3477		28,007.92	0.00	28,007.92			
989294	CHK	A	C SLAGTER CONSTRUCTION INC		839 1	5,800.00	.00	5,800.00	03/31/2026		24427
			Guardrail repair CR 125 N near	5686		5,800.00	0.00	5,800.00			
989295	CHK	A	CINTAS DISTRIBUTION LLC-ROAD		4479 2	961.36	.00	961.36	03/31/2026		24427
			Rd Uniforms Cleaned 3/9	4261992883		480.68	0.00	480.68			
			Rd Uniforms Cleaned 3/16	4262717655		480.68	0.00	480.68			
989296	CHK	A	GLEN CASH STORE INC		212 3	318.96	.00	318.96	03/31/2026		24427
			Water Pump Repair-Rd	A238121		28.98	0.00	28.98			
			Water Pump Rpr-Rd	A238132		99.99	0.00	99.99			
			Pensacola Bahia Grass-Rd	A238400		189.99	0.00	189.99			
989297	CHK	A	HAGAN ACE HARDWARE OF MACCLENN		221 5	610.81	.00	610.81	03/31/2026		24427
			Concrete Mix/CR127 Culvert-Rd	357702		328.52	0.00	328.52			
			UT1 Screws,Nuts,Bolts 12x-Fire	357704		3.20	0.00	3.20			
			Screws/Hornet Killer 4x-Rd	357737		38.79	0.00	38.79			
			UT1 Screws,Nuts,Bolts 8x-Fire	357757		1.12	0.00	1.12			
			ST70 Garbage Can 2x-Fire	357823		239.18	0.00	239.18			
989298	CHK	A	HENRY SCHEIN INC		588 1	1,561.14	.00	1,561.14	03/31/2026		24427
			Cath/Atropine/Epinephrine-EMS	54048543		1,561.14	0.00	1,561.14			
989299	CHK	A	ICE CUBE EXPRESS		75 1	148.50	.00	148.50	03/31/2026		24427
			10lb Bag Ice 110x-Rd	13025		148.50	0.00	148.50			

Bank Number: 1 / Name: First Federal / Description: Operating Account

Payment Number	Type	ID	Name	SRC	Num INV	Gross Amount	Discounts	Net Pay	Payment Date	HP Void	Batch
989300	CHK	A	L V HIERS INC 160 GA E10 UNL GAS-EMS 5Gal Blue DEF-Fire	267 493350 608137	2	605.11 545.11 60.00	.00 0.00 0.00	605.11 545.11 60.00	03/31/2026		24427
989301	CHK	A	LIFE SCAN WELLNESS CENTERS M COLLIER;T HOENIE;T KENNEDY;C M COLLIER;T HOENIE;T KENNEDY;C	4600 4316 4317	2	2,460.00 1,920.00 540.00	.00 0.00 0.00	2,460.00 1,920.00 540.00	03/31/2026		24427
989302	CHK	A	MES SERVICE COMPANY LLC UT11 RESCUE TOOL CUTTER-Fire	4637 2454601	1	2,600.00 2,600.00	.00 0.00	2,600.00 2,600.00	03/31/2026		24427
989303	CHK	A	NAPA AUTO PARTS- JAX015 Adapter/#5753 Airchuck-Rd #964 radiator/battery/recha-Rd	284 47705 47767	2	676.05 23.28 652.77	.00 0.00 0.00	676.05 23.28 652.77	03/31/2026		24427
989304	CHK	A	NEW RIVER SOLID WASTE ASSOCIAT Feb 2026 BOCC Tipping /sw	317 FEB26BOCC	1	17,769.30 17,769.30	.00 0.00	17,769.30 17,769.30	03/31/2026		24427
989305	CHK	A	NEXTRAN TRUCK CENTER 30lb Cyl Freon-Rd	318 04P218765	1	425.00 425.00	.00 0.00	425.00 425.00	03/31/2026		24427
989306	CHK	A	O'REILLY AUTOMOTIVE INC UT1 Mini Bulb-Fire UT1 1Gal Antifreeze 3x-Fire	1352 1897-199875 1897-200606	2	45.96 12.99 32.97	.00 0.00 0.00	45.96 12.99 32.97	03/31/2026		24427
989307	CHK	A	PITMAN ENGINEERING LLC CR125 Bridge erosion rpr/de-Rd	4504 26-02BAK02	1	5,365.00 5,365.00	.00 0.00	5,365.00 5,365.00	03/31/2026		24427
989308	CHK	A	PROGRESSIVE POWER PRODUCTS INC E20 ROAD CALL;TROUBLESHOOT TRA	4649 20703	1	823.45 823.45	.00 0.00	823.45 823.45	03/31/2026		24427
989309	CHK	A	RAULERSONVILLE, LLC well replacement-road yard/rd	465 NA014	1	1,900.00 1,900.00	.00 0.00	1,900.00 1,900.00	03/31/2026		24427
989310	CHK	A	RING POWER CORPORATION #1211 travel/diagnostic com-Rd	365 07WC1328204	1	825.78 825.78	.00 0.00	825.78 825.78	03/31/2026		24427
989311	CHK	A	SAFETY PRODUCTS INC Safety Vest 50x-Rd	755 2026-125761	1	149.95 149.95	.00 0.00	149.95 149.95	03/31/2026		24427
989312	CHK	A	SISTER SUSIE DRESSES & EMBROID SHIRTS,PATCHES,PANTS-EMS,Fire SHIRTS,PATCHES,PANTS-EMS,Fire	157 691 691	2	1,331.00 1,331.00 1,331.00	.00 0.00 0.00	1,331.00 976.00 355.00	03/31/2026		24427
989313	CHK	A	SKYBASE COMMUNICATIONS LLC SD7 LTE RADIOS/HOLSTER-Title	4529 38619	1	2,089.00 2,089.00	.00 0.00	2,089.00 2,089.00	03/31/2026		24427
989314	CHK	A	SOUTHEASTERN SERVICES INC site attendants through 3/8	387 128888	1	12,306.06 12,306.06	.00 0.00	12,306.06 12,306.06	03/31/2026		24427
989315	CHK	A	STAPLES ADVANTAGE Self Inking Stamp-CD Copy Paper 2x-CD Desk Calendar-CD	2164 6052662764 6053399006 6059405301	3	96.58 30.19 50.56 15.83	.00 0.00 0.00 0.00	96.58 30.19 50.56 15.83	03/31/2026		24427
989316	CHK	A	WALTER WALDING	1102	1	1,800.00	.00	1,800.00	03/31/2026		24427

Bank Number: 1 / Name: First Federal / Description: Operating Account

Payment Number	Type	ID	Name	SRC	Num INV	Gross Amount	Discounts	Net Pay	Payment Date	HP Void	Batch
			set benchmarks on Bill Davis R 2026-1			1,800.00	0.00	1,800.00			

---

Bank Number: 4 / Name: First Federal / Description: SHIP ACCOUNT

Payment Number	Type	ID	Name	SRC	Num INV	Gross Amount	Discounts	Net Pay	Payment Date	HP Void	Batch
2222	CHK	A	STACIE D. HARVEY, CLERK OF COU	279	1	35.50	.00	35.50	03/16/2026		24288
			RES26-2,4,5,6 Recorded	202601183		65.50	0.00	35.50			

---

REGISTER TOTALS    Checks: 248    Voids: 0                    582    1,339,589.11                    0.00    1,339,589.11



## BAKER COUNTY BOARD OF COUNTY COMMISSIONERS AGENDA ITEM REQUEST FORM

The Board of County Commissioners meet on the 1<sup>st</sup> and 3<sup>rd</sup> Tuesday of each month at 5:00 p.m. at the Baker County Administration Office, Commission Chambers, 55 North Third Street, Macclenny, FL 32063. All agenda items should be submitted to County Administration via [sara.little@bakercountyfl.org](mailto:sara.little@bakercountyfl.org) and [kayla.riggs@bakercountyfl.org](mailto:kayla.riggs@bakercountyfl.org) no later than the Wednesday prior to the Commission meeting.

**Date of Submission:** March 31, 2026                      **Meeting Date:** April 7, 2026

**Name of Submitter:** LaDonna Combs                      **Department:** Community Development

1. Nature and purpose of this agenda item:

Appointment status of LPA members

---

---

---

2. Recommended Motion/Action:

Re-appointment consideration for 2 members, Greg Sheppard and Gabe Powers.

---

---

---

3. Will this item require a presentation? No

4. Deadline for Completion: N/A

5. Fiscal Impact Questions:

Is this item included in the current budget? N/A

---

If item is grant related, is there a County match requirement? N/A

---

Explain the procurement process for this request (attach necessary documentation): N/A

---



**Baker County  
Community Development Department  
Planning ~ Permitting ~ Code Enforcement ~ Building ~ Outreach**

360 East Shuey Avenue  
Macclenny, Florida 32063  
Phone (904) 259-2403

March 31, 2026

**Re: Land Planning Agency Member Appointment**

The Land Planning Agency (LPA) is structured to have five (5) appointed members, one (1) School Board Member, and two (2) alternates. Currently, the LPA Board is filled with the following members reflecting their year of appointment expiration:

Gabe Powers, Chairman (February 2023)\* **Feb. 2026**  
Jack Kirkland, Vice Chairman (October 2023) **Oct.2026**  
Greg Sheppard, Member (February 2023)\* **Feb. 2026**  
Blake Britt, Member (October 2023) **Oct.2026**  
Nate Young, Member (June 2024) **June 2027**  
Franklin "Denny" Wells, (Until otherwise assigned) **N/A**  
Jared Lee, 1<sup>st</sup> Alternate (June 2024) **June 2027**  
VACANT, 2<sup>nd</sup> Alternate (---) **---**

**\*Terms have expired or are going to expire in the very near future.**

I have had discussions with the LPA Board Members and have confirmed that each of them has continued interest in serving as a member of the LPA Board. It is my recommendation that the Baker County Board of County Commissioners consider the re-appointment of the members whose term is or has expired. Applications are currently being accepted for new members.

Thank you for your consideration,

A handwritten signature in blue ink that reads "LaDonna Combs".

LaDonna Combs, Planning Director  
Community Development Department

Ron DeSantis, Florida Governor  
Tom Berger, Interim Secretary  
Warren Sponholtz, Florida State Chief Information Officer

---

**GRANT AGREEMENT**  
**FOR**  
**LOCAL GOVERNMENT CYBERSECURITY GRANT PROGRAM**  
**CONTRACT NO: DMS-25/26-115**  
**CATALOG OF STATE FINANCIAL ASSISTANCE NUMBER: 72.016**  
**BETWEEN**  
**THE STATE OF FLORIDA**  
**DEPARTMENT OF MANAGEMENT SERVICES**  
**AND**  
**BAKER COUNTY BOCC**

**This Grant Agreement** is made and entered into by and between the Department of Management Services (Department), an agency of the State of Florida (State), and Baker County BOCC (Grantee). The Department and the Grantee are sometimes referred to herein individually as a “Party” or collectively as the “Parties.”

THIS AGREEMENT IS ENTERED INTO BASED ON THE FOLLOWING REPRESENTATIONS:

**WHEREAS**, the Department, through the Florida Digital Service (FL[DS]), has the authority, pursuant to Specific Appropriation 2708, Fiscal Year 2025-2026 General Appropriations Act (GAA), to provide nonrecurring assistance to local governments for the development and enhancement of cybersecurity risk management programs; and

**WHEREAS**, the Grantee represents that it is fully qualified and eligible to receive the grant identified herein in accordance with the terms and conditions hereinafter set forth.

**NOW THEREFORE**, the Parties do mutually agree as follows:

**A. Deliverables and Performance Requirements:**

In accordance with the GAA, the Parties agree that the funds will be utilized as described in Attachment A – Solution Statement of Work. The Grantee shall provide the deliverables specified herein in accordance with the terms and conditions of this Agreement, including its attachments and exhibits.

**B. Agreement Period:**

The performance period for this Agreement begins upon execution and ends upon the expiration of the applicable cybersecurity technical assistance services or commodities awarded or purchased pursuant to the Agreement, or in accordance with the final implementation plan(s), unless terminated earlier in accordance with the Agreement. No renewals or extensions of this Agreement are permitted.

**C. Agreement Documents and Amendments Thereto.**

1. Agreement Documents. “Agreement” means this Grant Agreement and all incorporated attachments, exhibits, and schedules, which set forth the entire understanding of the Parties. There are no other provisions, terms, conditions, or obligations. This Agreement supersedes all previous oral or written communications, representations, or agreements on this subject.

All attachments, exhibits, and schedules listed below are incorporated in their entirety into, and will form part of, this Agreement. In the event of a conflict, the following order of precedence shall apply:

- a. This Grant Agreement
- b. Attachment A – Solution Statement of Work
- c. Attachment B – Audit Requirements for Awards of State and Federal Financial Assistance, including its Exhibit 1
- d. Attachment C – Grantee Data Sharing Agreement(s) (“DSA”), if applicable

## GRANT AGREEMENT

- a. Final Implementation Plan(s), if applicable
2. Counterparts. This Agreement may be executed in any number of counterparts, all of which taken together shall constitute one (1) single agreement between the Parties.
3. Survivability. This Agreement and any and all promises, covenants, and representations made herein are binding upon the Parties hereto and any and all respective heirs, assigns, and successors in interest. The respective obligations of the Parties, which by their nature would continue beyond the termination or expiration of this Agreement, including without limitation, the obligations regarding confidentiality, proprietary interests, and public records, shall survive termination or expiration of this Agreement.
4. Severability. If a court of competent jurisdiction deems any term or condition of this Agreement void or unenforceable, the other provisions are severable to that void provision, and will remain in full force and effect. However, to the fullest extent permitted by law, this Agreement shall be construed as if the scope or duration of such provision had been more narrowly drafted so as not to be invalid or unenforceable.
5. Amendments. With the exception of changes to the Primary Contacts, DSA/IT Coordinators, and the provisions of the applicable vendor terms and conditions, this Agreement may only be modified or amended by a written agreement duly executed by the Parties.

### D. Notices and Primary Contacts:

1. Notices. The Parties shall use the contact information provided in Section D.2., Primary Contacts, below, for all communications and notices under this Agreement. Where the term “written notice” is used to specify a notice requirement herein, said notice will be deemed to have been given (i) when personally delivered; (ii) when transmitted via facsimile (with confirmation of receipt) or email (with confirmation of receipt), provided the sender on the same day sends a confirming copy of such notice by a recognized delivery service (charges prepaid); (iii) the Business Day immediately following the next Business Day on which the notice or communication has been provided prepaid by the sender to a recognized overnight delivery service; or (iv) on the date actually received except where there is a date of the certification of receipt. For purposes of this Agreement, “Business Day” means any day of the week, excluding weekends and holidays, observed by State agencies pursuant to section 110.117(1)(a)-(j), Florida Statutes (F.S.).
2. Primary Contacts.
  - a. **Department’s Grant Manager** (see section 215.971, F.S.).

Brad Oswald, Enterprise Technology Coordinator  
Florida Digital Service  
Department of Management Services  
2555 Shumard Oaks Blvd  
Tallahassee, Florida 32399  
Telephone: (850) 413-0604

Email: [CybersecurityGrants@digital.fl.gov](mailto:CybersecurityGrants@digital.fl.gov)

a. **Grantee's Grant Manager**

Clint Shivers, DevOps Director  
Baker County BOCC  
55 N 3rd St  
Macclenny, Florida 32063  
Telephone: (904) 259-0201  
Email: [clint.shivers@bakercountyfl.org](mailto:clint.shivers@bakercountyfl.org)

3. Changes in Primary Contacts. Either Party may provide notice to the other Party by email identifying a change of a designated primary contact and providing the new contact information for the newly designated primary contact. Such notices must be sent to the other Party's Grant Manager and is sufficient to effectuate this change without requiring a written amendment to this Agreement.

**E. Payment, Funding, and Award Considerations:**

1. Fiscal Year. The funds utilized for this Agreement are from the State's 2025-2026 Fiscal Year, which begins July 1, 2025, and expires on June 30, 2026.
2. Services, Licenses or Commodities Awards. The Grantee agrees to implement services, licenses, or commodities described in Attachment A – Solution Statement of Work, according to the Final Implementation Plan(s), if applicable. All uses of the items described in Attachment A – Solution Statement of Work are subject to the terms and conditions of the DSA and applicable riders attached thereto.
3. Procurement. The Department agrees to purchase all commodities or services awarded to the Grantee on behalf of the Grantee as described in Attachment A – Solution Statement of Work.

**F. Compliance with Law:**

1. Applicable Law. The Parties shall comply with the applicable state and federal laws, rules, regulations, and policies, including, but not limited to, those identified in this Agreement.
2. Governing Law. The Grantee agrees that this Agreement is entered into in the State of Florida, and shall be construed, performed, and enforced in all respects in accordance with the laws, rules, and regulations of the State. Each Party shall perform its obligations herein in accordance with the terms and conditions of this Agreement. Without limiting the provisions of Section P, Dispute Resolution, the exclusive venue of any legal or equitable action that arises out of or relates to this Agreement shall be the appropriate State court in Leon County, Florida; in any such action, the Parties waive any right to jury trial. Except as otherwise provided by law, the Parties agree to be responsible for their own attorney fees incurred in connection with disputes arising under the terms of this Agreement.

1. Ethics. The Grantee shall comply with the requirements of sections 11.062 and 216.347, F.S. The Grantee shall not, in connection with this or any other agreement with the State, directly or indirectly:
  - a. Offer, confer, or agree to confer any pecuniary benefit on anyone as consideration for any State officer or employee's decision, opinion, recommendation, vote, other exercise of discretion, or violation of a known legal duty; or
  - b. Offer, give, or agree to give to anyone any gratuity for the benefit of, or at the direction or request of, any State officer or employee. For purposes of this subsection b, "gratuity" means any payment of more than nominal monetary value in the form of cash, travel, entertainment, gifts, meals, lodging, loans, subscriptions, advances, deposits of money, services, employment, or contracts of any kind.

Upon request of the Department's Inspector General, or other authorized State official, the Grantee shall provide any type of information the Inspector General deems relevant to the Grantee's integrity or responsibility. Such information may include, but shall not be limited to, the Grantee's business or financial records, documents, or files of any type or form that refer to or relate to this Agreement. The Grantee shall retain such records in accordance with the record retention requirements of Part V of Attachment B, Audit Requirements for Awards of State and Federal Financial Assistance.

4. Advertising. Subject to Chapter 119, F.S., the Grantee shall not publicly disseminate any information concerning this Agreement under any promotional activity, such as advertisements or press releases, without prior written approval from the Department.
5. Conflict of Interest. This Agreement is subject to Chapter 112, F.S. The Grantee shall disclose the name of any officer, director, employee, or other agent who has or potentially has a conflict of interest relating to this Agreement or funds received hereunder.
6. Records Retention. The Grantee shall retain all records made or received in conjunction with this Agreement for the longer of five (5) years after the end of this Agreement period and all pending matters or the period required by the General Records Schedules maintained by the Florida Department of State (available at: <https://dos.myflorida.com/media/703328/gs1-sl-2020.pdf>). If the Grantee's record retention requirements terminate prior to the requirements stated herein, the Grantee may meet the Department's record retention requirements for this Agreement by transferring its records to the Department at that time, and by destroying duplicate records in accordance with section 501.171, F.S., and, if applicable, section 119.0701, F.S. The Grantee shall adhere to established information destruction standards such as those established by the National Institute of Standards and Technology Special Publication NIST SP 800-88r2, "Guidelines for Media Sanitization" (2025). See <https://doi.org/10.6028/NIST.SP.800-88r2>.

#### **A. Recoupment of Funds:**

1. Notwithstanding the damages limitations of Section R, Limitation of Liability, if the Grantee's non-compliance with any provision of this Agreement results in additional costs or monetary

loss to the Department or the State, the Department can recoup the costs or losses from monies owed to the Grantee under this Agreement or any other agreement between the Grantee and any State entity. In the event that the discovery of additional costs or losses arises when no monies are available under this Agreement or any other agreement between the Grantee and any State entity, the Grantee shall repay such costs or losses to the Department in full within thirty (30) days from the date of discovery or notification, unless the Department agrees, in writing, to an alternative timeframe. The Department shall not be liable for any penalties or costs associated with the Grantee's misuse of any purchases made pursuant to this Agreement.

1. If the Grantee or its independent auditor discovers that an overpayment has been made, the Grantee shall repay said overpayment within forty (40) calendar days without prior notification from the Department. In the event that the Department first discovers an overpayment has been made, the Department will notify the Grantee in writing. Should repayment not be made in a timely manner, the Department shall be entitled to charge interest at the lawful rate of interest on the outstanding balance beginning forty (40) calendar days after the date of notification or discovery. Refunds should be sent to the Department's Agreement Manager and made payable to the "Department of Management Services." If this Agreement is terminated for cause, the Department, at its discretion, may require that the Grantee return to the Department any funds that were used for purposes that are considered ineligible under this Agreement.

#### **A. Audits and Records:**

1. Representatives of the Department, the State's Chief Financial Officer, the State's Auditor General, and representatives of the federal government, shall have access to any of the Grantee's books, documents, papers, and records, including electronic storage media, as they may relate to this Agreement, for the purposes of conducting audits or examinations or making excerpts or transcriptions.
2. The Grantee shall maintain books, records, and documents in accordance with the generally accepted accounting principles to sufficiently and properly reflect all purchases made under this Agreement.

The Grantee shall comply with all applicable requirements of section 215.97, F.S., and Attachment B, Audit Requirements for Awards of State and Federal Financial Assistance. If the Grantee is required to undergo an audit, the Grantee shall disclose all related party transactions to the auditor.

3. The Grantee shall retain all its records, financial records, supporting documents, statistical records, and any other documents, including electronic storage media, pertinent to this Agreement in accordance with the record retention requirements of Part V of Attachment B, Audit Requirements for Awards of State and Federal Financial Assistance. The Grantee shall cooperate with the Department to facilitate the duplication and transfer of such records or documents upon the Department's request.

1. If awarded services, licenses, or commodities described in Attachment A – Solution Statement of Work, the Grantee shall include records of the start and end dates for all tasks in the Final Implementation Plan(s), if applicable. Additional requirements may be incorporated in the Final Implementation Plan(s).
2. The Grantee shall include the aforementioned audit and recordkeeping requirements in all approved subrecipient contracts and assignments.

#### **A. Public Records and Records Production:**

1. Identification and Protection of Confidential Information. Article 1, section 24, Florida Constitution, guarantees every person access to all public records, and section 119.011, F.S., provides a broad definition of “public record.” As such, records submitted to the Department (or any other State agency) are public records and are subject to disclosure unless exempt from disclosure by law. The following records for agencies, as “agency” is defined in section 119.011(2), F.S., are confidential and exempt pursuant to section 119.0725, F.S.:
  - a. Cybersecurity insurance limits and deductibles;
  - b. Information relating to critical infrastructure;
  - c. Incident reporting information pursuant to sections 282.318 and 282.3185, F.S.;
  - d. Network schematics;
  - e. Hardware and software configurations; and
  - f. Encryption information or information that identifies detection, investigation, or response practices for suspected or confirmed cybersecurity incidents, including suspected or confirmed breaches.

If the Grantee considers any portion of other records it provides to the Department (or any other State agency) to be trade secret or otherwise confidential or exempt from disclosure under Florida or federal law, the Grantee shall mark the document as “confidential” and simultaneously provide the Department (or other State agency) with a separate, redacted copy of the record. Such records and those records made confidential and exempt pursuant to section 119.0725, F.S., shall be considered “Confidential Information.” For each portion redacted, the Grantee shall describe in writing the grounds for claiming the exemption, including the specific statutory citation for such exemption. The Grantee shall only redact portions of records that it claims are Confidential Information.

In the event of a request for public records pursuant to Chapter 119, F.S., the Florida Constitution, or other authority, to which records that are marked as “confidential” are responsive, the Department will provide the Grantee-redacted copy to the requestor. If a requestor asserts a right to the redacted Confidential Information, the Department will notify the Grantee such an assertion has been made. It is the Grantee’s responsibility to take the appropriate legal action to assert that the information in question is exempt from disclosure under Chapter 119, F.S., or other applicable law.

If the Department becomes subject to a demand for discovery or disclosure of documents that are marked as “confidential” in a legal proceeding, the Department will give the Grantee notice of the demand or request. The Grantee shall take the appropriate legal action in response to the demand and to defend its claims of confidentiality. If the Grantee fails to take appropriate and timely action to protect the records it has designated as Confidential Information, the Grantee agrees that the Department is permitted to treat those records as not confidential and the Department is permitted to provide the unredacted records to the requester and the Grantee agrees not to pursue any suit, action, or claim, including for damages, against the Department or its employees, attorneys, agents or volunteers.

The Grantee shall protect, defend, and indemnify the Department from all suits, claims, actions, demands, liability, costs, fines, and attorneys’ fees arising from or relating to the Grantee’s determination that the redacted portions of its records are Confidential Information, including all costs, including attorney’s fees, incurred regarding the entitlement or amount of such attorney’s fees. If the Grantee fails to submit a redacted copy in accordance with this section, of information it claims is Confidential Information, the Department is authorized to produce the entire record submitted to the Department, including those records marked “confidential,” in response to a public records request for, or demand for discovery or disclosure of, these records and the Grantee agrees not to pursue any suit, action, or claim, including for damages, against the Department or its employees, attorneys, agents, or volunteers.

1. Inspection of Records. In accordance with section 216.1366, F.S., the Department is authorized to inspect the: (a) financial records, papers, and documents of the Grantee that are directly related to the performance of this Agreement or the expenditure of State funds; and (b) programmatic records, papers, and documents of the Grantee which the Department determines are necessary to monitor the performance of this Agreement or to ensure that the terms of this Agreement are being met. The Grantee shall provide such records, papers, and documents requested by the Department within ten (10) Business Days after the request is made.

## **B. Non-Discrimination:**

The Grantee shall not unlawfully discriminate against any individual employed in the performance of this Agreement due to race, religion, color, sex, physical handicap unrelated to such person’s ability to engage in this work, national origin, ancestry, or age. The Grantee shall provide a harassment-free workplace, and any allegation of harassment shall be given priority attention and action.

## **C. Duty of Continuing Disclosure of Legal Proceedings and Instances of Fraud:**

1. The Grantee shall provide written notice to the Department disclosing any criminal litigation, investigation, or proceeding that arises during the Agreement period involving the Grantee except where the Grantee is involved in a prosecutorial or administrative capacity, or, to the

extent the Grantee is aware, any of the Grantee's subrecipients or contractors (or any of the foregoing entities' current officers or directors). The Grantee shall also provide written notice to the Department disclosing any civil litigation, arbitration, or proceeding that arises during the Agreement period that is related to or involves funds provided under this Agreement, to which the Grantee (or, to the extent the Grantee is aware, any subrecipient or contractor hereunder) is a party, and which:

- a. Might reasonably be expected to adversely affect the viability or financial stability of the Grantee or any subrecipient or contractor hereunder; or
- b. Involves a claim or written allegation of fraud against the Grantee, or any subrecipient or contractor hereunder, by a governmental or public entity arising out of business dealings with governmental or public entities.

All notices under this section must be provided to the Department within thirty (30) Business Days following the date that the Grantee first becomes aware of any such litigation, investigation, arbitration, or other proceeding (collectively, a "Proceeding"). Details of settlements that are prevented from disclosure by the terms of the settlement must be annotated as such.

1. This duty of disclosure applies to each officer and director of the Grantee, subrecipients, or contractors when any Proceeding relates to the officer's or director's business or financial activities.
2. Instances of Grantee operational fraud or criminal activities, regardless of whether a legal Proceeding has been initiated, shall be reported to the Department's Grant Manager within twenty-four (24) hours of the Grantee being made aware of the incident.
3. The Grantee shall promptly notify the Department's Grant Manager of any Proceeding relating to or affecting the Grantee's, subrecipient's, or contractor's business. If the existence of such Proceeding causes the State to conclude that the Grantee's ability or willingness to perform this Agreement is jeopardized, the Grantee shall be required to provide the Department's Grant Manager all reasonable assurances requested by the Department to demonstrate that:
  - a. The Grantee will be able to perform this Agreement in accordance with its terms and conditions; and
  - b. The Grantee and/or its employees, agents, subrecipients, or contractor(s) have not and will not engage in conduct in performance under this Agreement that is similar in nature to the conduct alleged in such Proceeding.

#### **A. Assignments, Subgrants, and Contracts:**

1. Unless otherwise specified in Attachment A – Solution Statement of Work, or through prior written approval of the Department, the Grantee may not: 1) subgrant any funds awarded

under this Agreement; 2) contract its duties or responsibilities under this Agreement out to a third party; or 3) assign, transfer, or sell any of the Grantee's rights or responsibilities, unless specifically permitted by law to do so. Any such subgrant, contract, or assignment occurring without the prior approval of the Department shall be null and void. In the event the Department approves transfer of the Grantee's obligations, the Grantee remains responsible for all work performed and all expenses incurred in connection with this Agreement. In addition, this Agreement shall bind the successors, assigns, and legal representatives of the Grantee, and of any legal entity that succeeds the Grantee, to the Grantee's obligations to the Department.

1. The Grantee agrees to be responsible for all work performed in fulfilling the obligations of this Agreement.
2. The Grantee agrees that the Department may assign or transfer its rights, duties, or obligations under this Agreement to another governmental entity upon giving prior written notice to the Grantee.

#### **B. Intellectual Property Rights:**

Where activities supported by this Agreement result in the creation of intellectual property rights, the Grantee shall notify the Department, and the Department will determine whether the Grantee will be required to grant the Department a perpetual, irrevocable, royalty-free, nonexclusive license to use, and to authorize others to use for State government purposes, any resulting patented, copyrighted, or trademarked work products developed under this Agreement.

#### **C. Independent Contractor Status:**

It is mutually understood and agreed to that at all times during the Grantee's performance of its duties and responsibilities under this Agreement that Grantee is acting and performing as an independent contractor. The Department shall neither have nor exercise any control or direction over the methods by which the Grantee shall perform its work and functions other than as provided herein. Nothing in this Agreement is intended to or shall be deemed to constitute a partnership or joint venture between the Parties.

1. The Grantee (and its officers, agents, employees, subrecipients, contractors, or assignees), in performance of this Agreement, shall act in the capacity of an independent contractor and not as an officer, employee, or agent of the State. Further, unless specifically authorized to do so, the Grantee shall not represent to others that, as the Grantee, it has the authority to bind the Department or the State.
2. Neither the Grantee nor its officers, agents, employees, subrecipients, contractors, or assignees, are entitled to State retirement or State leave benefits, or to any other compensation of State employment as a result of performing the duties and obligations of this Agreement.

1. The Grantee agrees to take such actions as may be necessary to ensure that each subrecipient or contractor will also be deemed to be an independent contractor and will not be considered or permitted to be an agent, servant, joint venturer, or partner of the State.
2. Unless agreed to by the Department in Attachment A – Solution Statement of Work, the Department will not furnish services of support (e.g., office space, office supplies, telephone service, secretarial, clerical support, etc.) to the Grantee or its subrecipient, contractor, or assignee.
3. The Department shall not be responsible for withholding taxes with respect to the Grantee's compensation hereunder. The Grantee shall have no claim against the Department for vacation pay, sick leave, retirement benefits, social security, workers' compensation, health or disability benefits, reemployment assistance benefits, or employee benefits of any kind. The Grantee shall ensure that its employees, subrecipients, contractors, and other agents, receive benefits and necessary insurance (health, workers' compensation, reemployment assistance benefits) from an employer other than the State.
4. At all times during the Agreement period, the Grantee must comply with the reporting and Reemployment Assistance contribution payment requirements of chapter 443, F.S.

**A. Termination:**

1. Termination for Failure to Implement. For awarded services, licenses, or commodities under Attachment A – Solution Statement of Work, if the Grantee does not approve a Final Implementation Plan before June 22, 2026, for the awarded solutions, this Agreement may be terminated by the Department, at its sole discretion.
2. Termination Due to the Lack of Funds. The funds utilized for this Agreement are from the State's 2025-2026 Fiscal Year, which begins July 1, 2025, and expires on June 30, 2026. If funds become unavailable for this Agreement's purpose, such event will not constitute a default by the Department or the State. The Department agrees to notify the Grantee in writing at the earliest possible time if funds are no longer available. In the event that any State funds upon which this Agreement depends are withdrawn or redirected, the Department may terminate this Agreement by providing written notice to the Grantee. The Department will be the final authority as to the availability of funds.
3. Termination for Cause. The Department may terminate this Agreement if the Grantee fails to:
  - a. Satisfactorily complete the deliverables within the time specified in this Agreement;
  - b. Maintain adequate progress, thus endangering performance of this Agreement;
  - c. Honor any term of this Agreement; or
  - d. Abide by any statutory, regulatory, or licensing requirement.

The Grantee shall continue to perform any work not terminated. The Department's rights and remedies in this clause are in addition to any other rights and remedies provided by law

or under this Agreement. The Grantee shall not be entitled to recover any cancellation charges or lost profits.

1. Termination for Convenience. The Department may terminate this Agreement, in whole or in part, by providing written notice to the Grantee that the Department determined, in its sole discretion, it is in the State's interest to do so. The Grantee shall not furnish any product or continue services after the specified termination date in the Department's notice of termination, except as necessary to complete the continued portion of this Agreement, if any. The Grantee will not be entitled to recover any cancellation charges or lost profits.
2. Grantee's Responsibilities upon Termination. If the Department provides a notice of termination to the Grantee, except as otherwise specified by the Department in that notice, the Grantee shall:
  - a. Stop work under this Agreement on the date and to the extent specified in the notice.
  - b. Complete performance of such part of the work that has not been terminated by the Department, if any.
  - c. Take such action as may be necessary, or as the Department may specify, to protect and preserve any property which is in the possession and custody of the Grantee, and in which the Department has or may acquire an interest.
  - d. Transfer, assign, and make available to the Department all property and materials belonging to the Department upon the effective date of termination of this Agreement. No extra compensation will be paid to the Grantee for its services in connection with such transfer or assignment.

#### **A. Dispute Resolution:**

Disputes concerning performance under this Agreement will be decided by the Department, who shall reduce the decision to writing and serve a copy to the Grantee.

#### **B. Unauthorized Use:**

1. The Grantee shall fully defend and hold harmless the State and the Department from any suits, actions, damages, and costs of every name and description, including attorneys' fees, arising from or relating to violation or infringement of a trademark, copyright, patent, trade secret, or intellectual property right provided, however, that the foregoing obligation shall not apply to the Department's misuse or modification of the Grantee's products or the Department's operation or use of the Grantee's products in a manner not contemplated by the Agreement. The Department will not be liable for any royalties.
2. The Grantee shall not be liable for any cost, expense, or compromise incurred or made by the State or the Department in any legal action without the Grantee's prior written consent, which shall not be unreasonably withheld. The State and the Department shall have the right, at its own cost and expense, to participate in all actions under this Section Q.

1. For the avoidance of doubt, as the Grantee is a subdivision, as defined in section 768.28(2), F.S., pursuant to section 768.28(19), F.S., neither Party indemnifies nor insures or assumes any liability to the other Party for the other Party's negligence. Notwithstanding anything to the contrary in this Section Q, liability of either Party for tort claims is limited to the amounts prescribed in section 768.28, F.S., plus the Party's reasonable attorneys' fees.

**A. Limitation of Liability:**

1. Unless otherwise specifically enumerated in this Agreement, no Party shall be liable to the other Party for special, indirect, punitive, or consequential damages, including lost data or records (unless this Agreement requires the Grantee to back-up data or records), even if the Party has been advised that such damages are possible. No Party shall be liable to the other Party for lost profits, lost revenue, or lost institutional operating savings. The State and the Department may, in addition to other remedies available to them at law or in equity and upon notice to the Grantee, retain such monies from amounts due the Grantee as may be necessary to satisfy any claim for damages, penalties, costs, and the like asserted by or against them. Except as otherwise provided in this Agreement or the Data Sharing Agreement or its attachments or Riders, the Department is not liable for unauthorized access to information except as directly attributable to the actions of the Department. For all claims against Grantee under this Agreement, and regardless of the basis on which the claim is made, Grantee's liability under this Agreement for direct damages shall be limited to the dollar value of this Agreement. This limitation shall not apply to claims arising under Section Q of this Agreement.
2. Pursuant to Specific Appropriation 2708 and Section 211 of the 2025-2026 General Appropriations Act, the State is hereby released from all liability related to cybersecurity incidents impacting the Grantee.

**B. Force Majeure and Notice of Delay from Force Majeure:**

Neither Party shall be liable to the other for any delay or failure to perform under this Agreement if such delay or failure is neither the fault nor caused by the negligence of the Party or its employees or agents and the delay is due directly to acts of God, wars, acts of public enemies, strikes, fires, floods, or other similar cause wholly beyond the Party's control, or for any of the foregoing that affects subrecipients, contractors, or suppliers if no alternate source of supply is available. However, in the event a delay arises from the foregoing causes, the Party shall take all reasonable measures to mitigate any and all resulting damages, costs, delays, or disruptions to the project in accordance with the Party's performance requirements under this Agreement.

In the case of any delay the Grantee believes is excusable under this section, the Grantee shall provide written notice to the Department describing the delay or potential delay and the cause of the delay within: ten (10) calendar days after the cause that creates or will create the delay first arose (if the Grantee could reasonably foresee that a delay could occur as a result); or five (5) calendar days after the date the Grantee first had reason to believe that a delay could result (if the delay is not reasonably foreseeable). **THE FOREGOING SHALL CONSTITUTE THE GRANTEE'S SOLE REMEDY OR EXCUSE WITH RESPECT TO DELAY.** Providing notice in strict accordance with this section is a condition precedent to such remedy.

The Department, in its sole discretion, will determine if the delay is excusable under this section and will notify the Grantee of its decision in writing. The Grantee shall not assert a claim for damages, other than for an extension of time, against the Department. The Grantee will not be entitled to an increase in the Agreement price or payment of any kind from the Department for any reason. If performance is suspended or delayed, in whole or in part, due to any of the causes described in this section, after the causes have ceased to exist, the Grantee shall resume performance, unless the Department determines, in its sole discretion, that the delay will significantly impair the ability of the Grantee to timely complete its obligations under this Agreement, in which case, the Department may terminate this Agreement in whole or in part.

#### **A. Mandatory Disclosure Requirements:**

1. Convicted Vendor List. The Grantee has a continuous duty to disclose to the Department if the Grantee or any of its affiliates, as defined by section 287.133(1)(a), F.S., are placed on the convicted vendor list. Pursuant to section 287.133(2)(a), F.S.: “A person or affiliate who has been placed on the convicted vendor list following a conviction for a public entity crime may not submit a bid, proposal, or reply on a contract to provide any goods or services to a public entity; may not submit a bid, proposal, or reply on a contract with a public entity for the construction or repair of a public building or public work; may not submit bids, proposals, or replies on leases of real property to a public entity; may not be awarded or perform work as a contractor, supplier, subcontractor, or consultant under a contract with any public entity; and may not transact business with any public entity in excess of the threshold amount provided in s. 287.017, F.S., for CATEGORY TWO for a period of 36 months following the date of being placed on the convicted vendor list.”
2. Discriminatory Vendor List. The Grantee has a continuous duty to disclose to the Department if the Grantee or any of its affiliates, as defined by section 287.134(1)(a), F.S., are placed on the discriminatory vendor list. Pursuant to section 287.134(2)(a), F.S.: “An entity or affiliate who has been placed on the discriminatory vendor list may not submit a bid, proposal, or reply on a contract to provide any goods or services to a public entity; may not submit a bid, proposal, or reply on a contract with a public entity for the construction or repair of a public building or public work; may not submit bids, proposals, or replies on leases of real property to a public entity; may not be awarded or perform work as a contractor, supplier, subcontractor, or consultant under a contract with any public entity; and may not transact business with any public entity.”
3. Antitrust Violator Vendor List. The Grantee has a continuous duty to disclose to the Department if the Grantee or any of its affiliates, as defined by section 287.137(1)(a), F.S., are placed on the antitrust violator vendor list. Pursuant to section 287.137(2)(a), F.S.: “A person or an affiliate who has been placed on the antitrust violator vendor list following a conviction or being held civilly liable for an antitrust violation may not submit a bid, proposal, or reply for any new contract to provide any goods or services to a public entity; may not submit a bid, proposal, or reply for a new contract with a public entity for the construction or repair of a public building or public work; may not submit a bid, proposal, or reply on new leases of real property to a public entity; may not be awarded or perform work as a contractor,

supplier, subcontractor, or consultant under a new contract with a public entity; and may not transact new business with a public entity.”

1. Foreign Gifts and Contracts. The Grantee shall comply with any applicable disclosure requirements in section 286.101, F.S. Pursuant to section 268.101(7), F.S.: “In addition to any fine assessed under [section 286.101(7)(a), F.S.], a final order determining a third or subsequent violation by an entity other than a state agency or political subdivision shall automatically disqualify the entity from eligibility for any grant or contract funded by a state agency or any political subdivision until such ineligibility is lifted by the Administration Commission for good cause.”

REMAINDER OF PAGE INTENTIONALLY LEFT BLANK



## BAKER COUNTY BOARD OF COUNTY COMMISSIONERS AGENDA ITEM REQUEST FORM

The Board of County Commissioners meet on the 1<sup>st</sup> and 3<sup>rd</sup> Tuesday of each month at 5:00 p.m. at the Baker County Administration Office, Commission Chambers, 55 North Third Street, Macclenny, FL 32063. All agenda items should be submitted to County Administration via [sara.little@bakercountyfl.org](mailto:sara.little@bakercountyfl.org) and [kayla.riggs@bakercountyfl.org](mailto:kayla.riggs@bakercountyfl.org) no later than the Wednesday prior to the Commission meeting.

**Date of Submission:** April 6, 2026                      **Meeting Date:** April 7, 2026

**Name of Submitter:** Kayla Riggs                      **Department:** Administration

1. Nature and purpose of this agenda item:  
Plant AS inducement and development agreement, 10th amendment. This amendment extends the term to May 1, 2026 to allow Plant AS adequate time to close on the property.

2. Recommended Motion/Action:  
approve the agreement as submitted.

3. Will this item require a presentation? No, consent agenda item.

4. Deadline for Completion: 05/01/2026

5. Fiscal Impact Questions:

Is this item included in the current budget? na

If item is grant related, is there a County match requirement? na

Explain the procurement process for this request (attach necessary documentation): na

## TENTH AMENDMENT TO INDUCEMENT AND DEVELOPMENT AGREEMENT

**THIS TENTH AMENDMENT TO INDUCEMENT AND DEVELOPMENT AGREEMENT** (this “Amendment”) is made as of the 7 day of April, 2026, by and among **BAKER COUNTY, FLORIDA**, a political subdivision of the State of Florida (“Baker County”), the **BAKER COUNTY DEVELOPMENT COMMISSION**, an independent special district and public corporation of the State of Florida, within the statutory boundaries of Baker County, FL (“Development Commission”), and **PLANT AGRICULTURAL SYSTEMS LLC**, a Delaware limited liability company (“PLANT-AS”), collectively with its affiliates, subsidiaries, and designees, including, but not limited to, **PLANT-4TMRW-FOOD INC**, a Delaware nonprofit corporation (collectively, the “Company”).

**WHEREAS**, Baker County, the Development Commission and Company have entered into that certain Inducement and Development Agreement dated April 12, 2023, (“Agreement”) regarding a “Controlled Environment Agriculture Distributed Network Production Site” to be constructed on approximately 772 acres of land located within the Woodstock Industrial Site in Baker County, Florida; and,

**WHEREAS**, Baker County, the Development Commission and Company have previously entered into that certain Amendment to Inducement and Development Agreement dated September 6, 2023, (the “First Amendment”); and

**WHEREAS**, Baker County, the Development Commission and Company have previously entered into that certain Second Amendment to Inducement and Development Agreement dated March 12, 2024, (the “Second Amendment”); and

**WHEREAS**, Baker County, the Development Commission and Company have previously entered into that certain Third Amendment to Inducement and Development Agreement dated July 16, 2024, (the “Third Amendment”); and

**WHEREAS**, Baker County, the Development Commission and Company have previously entered into that certain Fourth Amendment to Inducement and Development Agreement dated September 24, 2024, (the “Fourth Amendment”); and

**WHEREAS**, Baker County, the Development Commission and Company have previously entered into that certain Fifth Amendment to Inducement and Development Agreement dated November 19, 2024, (the “Fifth Amendment”); and

**WHEREAS**, Baker County, the Development Commission and Company have previously entered into that certain Sixth Amendment to Inducement and Development Agreement dated March 4, 2025, (the “Sixth Amendment”); and

**WHEREAS**, Baker County, the Development Commission and Company have previously entered into that certain Seventh Amendment to Inducement and Development Agreement dated as of May 31, 2025, (the “Seventh Amendment”); and

**WHEREAS**, Baker County, the Development Commission and Company have previously entered into that certain Eighth Amendment to Inducement and Development Agreement dated as of October 21, 2025, (the “Eighth Amendment”);

**WHEREAS**, Baker County, the Development Commission and Company have previously entered into that certain Ninth Amendment to Inducement and Development Agreement dated as of January 20, 2026, (the “Ninth Amendment”); and

**WHEREAS**, Baker County, the Development Commission and Company have agreed to further modify the date of “Closing” defined in the Agreement, as modified, to May 1, 2026.

**NOW, THEREFORE**, in consideration of the mutual covenants and premises contained herein and for other good and valuable consideration, the receipt and sufficiency of which is hereby acknowledged, the parties hereby agree as follows:

1. The Recitals are true and correct and are incorporated by this reference thereto.
2. The first paragraph of Section I of the Agreement (for the purpose of clarity, not including the portion of Section I that begins with “The “Closing Conditions” shall be the following:” and continues with subsections A, B, C, and D that follow such statement as contained within Section I) is amended in its entirety to read as follows:

**I. CONVEYANCE OF LAND**

Contingent only upon satisfaction of the Closing Conditions as provided below and simultaneously upon its acquisition of the Land, the Development Commission shall convey to the Company, and the Company shall accept from the Development Commission, fee simple title in and to the Land in the same form as received by the Development Commission, including the Harvesting Easement and the Access Easement, as defined in the Property Agreement, and the matters set forth in the Title Commitment, attached hereto as Exhibit B, with such Land and title not encumbered by any monetary lien, together with all of the Development Commission’s right, title, and interest, if any, in and to (i) all improvements of every nature whatsoever located in or on, or attached to, the Land; (ii) all of the Development Commission’s right, title, and interest with respect to the Land and all development rights, approvals and permits relating solely to the Land held by the Development Commission, to the extent assignable, and without the payment of any fee by the Development Commission, and (iii) all recorded easements, rights of way, gores of land, streets, ways, alleys, passages, and all estates, rights, titles, interests, privileges, liberties, tenements, hereditaments, and appurtenances whatsoever, in any way belonging, relating, or appertaining to the Land (collectively, the “Land”), without cost to the Company and solely in consideration for the Company entering into this Agreement and the terms and conditions contained herein, the receipt, adequacy, and sufficiency of which consideration is hereby acknowledged by the Development Commission and Baker County (such transactions, collectively, the “Conveyance”). It is anticipated that the Closing Conditions will be satisfied on or prior to May 1, 2026. The closing of the transactions contemplated hereby (“Closing”) shall be conducted through escrow at the offices of Smith Hulsey & Busey (“Escrow Agent”) as of a date

agreed upon by the parties hereto and no later than May 1, 2026, simultaneously with the closing under the Property Agreement, pursuant to a mutually acceptable escrow agreement (“Escrow Agreement”). All original deliverables shall be deposited with Escrow Agent on or before 2:00 p.m. (Eastern Time) on the day prior to Closing. The parties will enter into additional closing related agreements, instruments, and documents to effect the transactions contemplated herein and memorialize certain additional terms and conditions related to the Conveyance, including, without limitation, an Escrow Agreement that will set forth terms and conditions related to the timing of certain transactions related thereto. Notwithstanding the foregoing, the Conveyance will automatically be deemed effected and final and the Development Commission will deliver to the Company and the Company will accept and have fee simple title to the Land with such Land and title not encumbered by any monetary lien along with a deed memorializing the foregoing, and any contingencies for the Conveyance shall be satisfied in full, upon satisfaction of the Closing Conditions. For the sake of clarity, no further action by any of the parties to this Agreement need be taken in order for the Conveyance to be deemed effective for all purposes from and after the satisfaction of the Closing Conditions.

3. This Amendment constitutes the only agreement between the parties regarding the modification of the Agreement and the subject matter thereof as set forth herein. All other provisions of the Agreement not amended hereby remain in full force and effect. To the extent of any conflict between the Agreement (as modified by the First Amendment, the Second Amendment, the Third Amendment, the Fourth Amendment, the Fifth Amendment, the Sixth Amendment, the Seventh Amendment, Eighth Amendment and the Ninth Amendment) and this Amendment, this Amendment shall control.

4. This Amendment may be executed in counterparts, each of which will be deemed an original, but all of which together will be deemed to be one and the same instrument. Counterparts may be delivered digitally or via electronic mail (including PDF or any electronic signature complying with the U.S. federal ESIGN Act of 2000) or other transmission method, and any counterpart so delivered will be deemed to have been duly and validly delivered and be valid and effective for all purposes.

***Signature Page Follows.***

**IN WITNESS WHEREOF**, and as authorized respectively by the Development Commission, Baker County, and the Company, the parties have executed this Amendment to be effective as of the day and year first written above.

**“DEVELOPMENT COMMISSION”**

ATTEST:

**BAKER COUNTY DEVELOPMENT COMMISSION**, an independent special district and public corporation of the State of Florida, within the statutory boundaries of Baker County, Florida

\_\_\_\_\_

By: \_\_\_\_\_  
Name: \_\_\_\_\_  
Its: \_\_\_\_\_

**“BAKER COUNTY”**

ATTEST:

**BAKER COUNTY, FLORIDA**, a political subdivision of the State of Florida

\_\_\_\_\_

By: Board of Commissioners

By: \_\_\_\_\_  
Name: \_\_\_\_\_  
Its: Chairman

**“PLANT-AS”**

ATTEST:

**PLANT AGRICULTURAL SYSTEMS LLC**, a Delaware limited liability company

\_\_\_\_\_

By: \_\_\_\_\_  
Name: \_\_\_\_\_  
Its: \_\_\_\_\_



## BAKER COUNTY BOARD OF COUNTY COMMISSIONERS AGENDA ITEM REQUEST FORM

The Board of County Commissioners meet on the 1<sup>st</sup> and 3<sup>rd</sup> Tuesday of each month at 5:00 p.m. at the Baker County Administration Office, Commission Chambers, 55 North Third Street, Macclenny, FL 32063. All agenda items should be submitted to County Administration via [sara.little@bakercountyfl.org](mailto:sara.little@bakercountyfl.org) and [kayla.riggs@bakercountyfl.org](mailto:kayla.riggs@bakercountyfl.org) no later than the Wednesday prior to the Commission meeting.

**Date of Submission:** April 2, 2026 **Meeting Date:** April 7, 2026

**Name of Submitter:** Kayla Riggs **Department:** Admin

1. Nature and purpose of this agenda item:  
Proclamation - Sexual Assault Awareness. This is a request from Women's Center of Jacksonville.  
Recognizing April 2026 as Sexual Assault Awareness Month.

2. Recommended Motion/Action:  
Approval of Proclamation as presented.

3. Will this item require a presentation? No, Item backup document only.

4. Deadline for Completion: April 2026

5. Fiscal Impact Questions:

Is this item included in the current budget? na

If item is grant related, is there a County match requirement? na

Explain the procurement process for this request (attach necessary documentation): na

**Sexual Assault Awareness Month**

**April 2026**

WHEREAS, April marks Sexual Assault Awareness Month (SAAM), a time to honor 25 years of progress and recommit to creating safe communities for all. This year’s theme, “25 Years Strong: Looking Back, Moving Forward,” celebrates the resilience of survivors and the communities that have worked for changed;

WHEREAS, for 25 years, SAAM has supported survivors, raised awareness, and inspired action to prevent sexual assault, abuse, and harassment. As we reflect on how far we have come, we also recognize the work that lies ahead;

WHEREAS, prevention starts with all of us. It is in how we support one another, practice consent, and create spaces rooted in care and respect. When we act with intention, we move closer to a future free from violence;

WHEREAS, we honor survivors who have shared their stories and the advocates who have led the way. Their courage reminds us that prevention is possible and that each of us has a role to play;

WHEREAS, as we look to the next 25 years, we renew our commitment to building a future free from sexual violence. Together, we can continue to strengthen prevention, support healing, and create communities where everyone feels safe and valued.

25 years strong. Every voice matters. Every action counts. By standing in solidarity, we can build a future free from sexual violence and create a world where everyone is safe, valued, and respected.

NOW, THEREFORE, WE, the Baker County Board of County Commissioners, join with advocates and community members in raising awareness about sexual violence and serving those who have been harmed. I do hereby proclaim April 2026 as Sexual Assault Awareness Month.

**BAKER COUNTY BOARD  
OF COUNTY COMMISSIONERS**

---

**Ronald Mann, Chairman**

**Attest:**

---

**Stacie D. Harvey, Clerk**



## BAKER COUNTY BOARD OF COUNTY COMMISSIONERS AGENDA ITEM REQUEST FORM

The Board of County Commissioners meet on the 1<sup>st</sup> and 3<sup>rd</sup> Tuesday of each month at 5:00 p.m. at the Baker County Administration Office, Commission Chambers, 55 North Third Street, Macclenny, FL 32063. All agenda items should be submitted to County Administration via [sara.little@bakercountyfl.org](mailto:sara.little@bakercountyfl.org) and [kayla.riggs@bakercountyfl.org](mailto:kayla.riggs@bakercountyfl.org) no later than the Wednesday prior to the Commission meeting.

**Date of Submission:** April 2, 2026 **Meeting Date:** April 7, 2026

**Name of Submitter:** Sara Little **Department:** Administration

1. Nature and purpose of this agenda item:  
LPA Alternate Member Appointment- due to a vacancy on the LPA Board, staff advertised for applications for volunteers. Applications were accepted, reviewed and a recommendation to the BOCC prepared.

2. Recommended Motion/Action:  
Approve Mr. Chandler as the LPA Alternate Member.

3. Will this item require a presentation? No

4. Deadline for Completion: ASAP due to Quorum issues

5. Fiscal Impact Questions:

Is this item included in the current budget? NA

If item is grant related, is there a County match requirement? NA

Explain the procurement process for this request (attach necessary documentation): NA



## BAKER COUNTY BOARD OF COUNTY COMMISSIONERS AGENDA ITEM REQUEST FORM

The Board of County Commissioners meet on the 1<sup>st</sup> and 3<sup>rd</sup> Tuesday of each month at 5:00 p.m. at the Baker County Administration Office, Commission Chambers, 55 North Third Street, Macclenny, FL 32063. All agenda items should be submitted to County Administration via [sara.little@bakercountyfl.org](mailto:sara.little@bakercountyfl.org) and [kayla.riggs@bakercountyfl.org](mailto:kayla.riggs@bakercountyfl.org) no later than the Wednesday prior to the Commission meeting.

**Date of Submission:** April 2, 2026 **Meeting Date:** April 7, 2026

**Name of Submitter:** Sara Little **Department:** Administration

1. Nature and purpose of this agenda item:  
Approval of Engagement Letters with Bryant Miller Olive for Impact Fee Study and Solid Waste  
Special Assessment study.

2. Recommended Motion/Action:  
Engagement Letters are within budgeted amount. Staff recommends approval of both. Peter  
Napoli with Stantec will be present for questions. Stantec is the subconsultant of Bryant Miller Olive that  
will perform the data collection for the study.

3. Will this item require a presentation? No

4. Deadline for Completion: ASAP.

5. Fiscal Impact Questions:

Is this item included in the current budget? Yes, \$100,000

If item is grant related, is there a County match requirement? NA

Explain the procurement process for this request (attach necessary documentation): Florida  
Statutes exempts legal services from procurement process.

March 19, 2026

**VIA EMAIL ONLY**

Sara Little, County Manager  
Baker County, Florida  
55 North 3rd Street  
Macclenny, FL 32063

Re: Professional Services Related to Development and Implementation of Impact Fees

Dear Ms. Little:

Thank you for considering Bryant Miller Olive (the "Firm") for purposes of assisting Baker County (the "County") with developing and adopting impact fees for transportation, schools, parks, fire rescue, emergency medical services, and law enforcement. As further described in the scope of services description below, our assistance will include developing the methodologies used by the County to calculate the impact fees and preparing the County ordinance or ordinances providing for imposition, collection and administration of the impact fees. The Firm has extensive experience in this field, and we would be pleased to provide related professional services to the County. This letter sets forth the terms by which the Firm will provide such services.

At the outset we note that accomplishing the County's objectives will necessarily require more than legal expertise. We propose collaborating with the Stantec consulting firm (the "Methodology Consultant") which will, among other things, perform the numerical calculations associated with developing the impact fee methodologies. In the engagement, the Firm will have an attorney-client relationship with the County and will collaborate with the Methodology Consultant as a sub-consultant hereunder.

The anticipated scope of services for updating the impact fees is outlined below, and additional detail is included in the Methodology Consultant's proposal attached hereto as Exhibit "A".

1. Developing the methodologies used by the County to calculate the impact fees.
2. Drafting a comprehensive impact fee ordinance or ordinances for adoption by the County related to imposition, collection and administration of impact fees, including drafting any amendments to existing code provisions, and related notices of the impact fees.

3. Research and advice regarding state law governing impact fees and any changes or updates thereto.
4. Preparing written memoranda when necessary.
5. Preparing one or more written reports documenting the calculation of the impact fees and related matters.
6. Appearing at County meetings to present the impact fees and assist with the process of implementation.

### **FEES AND EXPENSES**

I will be the attorney primarily responsible for the legal aspects of the work effort. The County will be billed for my time at my standard hourly rate of \$350.00 per hour. As appropriate, certain tasks may be assigned to associates and paralegals. Work performed by associates will be billed at \$275.00 per hour, and work performed by paralegals will be billed at \$125.00 per hour, respectively. We estimate that the legal fees will not exceed a total of \$17,500. In addition, the Methodology Consultant will charge a fixed fee of \$74,640 as outlined in their attached proposal. The cost estimates summarized above are for professional fees only.

In the current undertaking where two or more impact fee programs are addressed simultaneously, there are typically efficiencies and economies of scale which help to minimize overall costs. While the cost estimates set forth above are conservative and actual costs may be less in light of cost-efficiencies and economies of scale, the direction of the County will control and matters of outside influence beyond the control of the County and/or the Firm may impact the anticipated work effort.

In addition to hourly rates, the Firm will invoice for reimbursement for actual costs incurred, such as computer printing or photocopies, long distance telephone charges and travel expenses which will be reimbursed in accordance with Section 112.061, Florida Statutes. For budgeting purposes, reimbursements for actual costs are not expected to exceed 2% of the professional fees. We will bill periodically, but not less often than monthly, by detailed invoice reflecting hours and expenses with all appropriate back-up materials typically required by governmental entities.

The County may cancel or terminate this engagement at any time upon written notice to the Firm. In the event of termination of this engagement, the Firm and Methodology Consultant will immediately cease work and shall be reimbursed for eligible and documented time and reimbursable expenses incurred prior to the notice to stop work.

Sara Little  
Baker County, Florida  
March 19, 2026  
Page 3 of 3

If the terms and conditions described in this letter are acceptable, please direct us to proceed by returning a signed copy for our files. We look forward to working with you and greatly appreciate this opportunity to serve Baker County.

Sincerely,

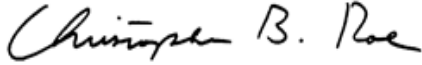

Christopher B. Roe, Shareholder

cc: Richard Komando, County Attorney  
Peter Napoli, Stantec

Direction to proceed this \_\_\_\_\_ day of \_\_\_\_\_, 2026:

By: \_\_\_\_\_

Print: \_\_\_\_\_

Title: \_\_\_\_\_

**EXHIBIT "A"**

**STANTEC PROPOSAL**



December 15, 2025

Sara Little, County Manager  
Baker County Administration  
55 North Third Street  
Macclenny, FL 32063  
(904)259-3613

Re: Baker County Impact Fee Study

Dear Ms. Little:

Stantec has prepared the following proposal to conduct the above referenced Impact Fee Study (Study) for Baker County's transportation, schools, parks, fire rescue, emergency medical services, and law enforcement impact fees.

**Project Description**

Stantec has prepared this proposal to conduct an Impact Fee Study in which we would prepare impact fees for eight of the County's service departments listed above. With 30+ years of experience, Stantec has developed a thorough and effective approach to the development, review, and creation of impact fees. Stantec's familiarity with Florida impact fee statutes and Florida growth management legislation will guide our calculation of impact fees for the County's consideration.

**Scope of Services**

This project includes the calculation and implementation of transportation, schools, parks, fire rescue, emergency medical services, and law enforcement (6 total) impact fees using the most recent and localized data available. Stantec will work with your staff to interpret and process the County's capital improvement plans, fixed asset data, funding history, and level of service standards to inform the calculation of impact fees. Stantec will also establish the elements of the impact fee structure and methodology that are necessary to best fit the County's unique profile. Stantec will perform a comparative survey of up to 10 neighboring communities impact fees including the County's proposed impact fees.

During this project Stantec will conduct several virtual work sessions with you and your staff in which we will explore various scenarios and confirm key inputs and assumptions. Thereafter, Stantec will provide you the schedules of the proposed impact fees and assumptions upon which the results are based. This will allow you and your staff to review the results in detail.

**Presentations and Deliverables**

Upon completion of the analyses, Stantec will prepare a presentation of the results, review the presentation with you, and present the resulting proposed impact fees to the County Commission in two (2) meetings. Stantec will incorporate any adjustments to the analyses necessary based upon input from the County



Commission and prepare a draft report for your review and comment. Stantec will incorporate any comments and prepare and deliver a Final Report including the underlying assumptions and methodologies used for each of the impact fee categories.

### **Time of Performance**

The Consultant (Stantec) proposes to begin the Study upon receipt of a notice-to-proceed from the County. The study will be completed within 150 days of receipt of all requested data. This schedule is contingent upon County staff availability for meetings and responsiveness to review draft deliverables.

### **Consultant's Compensation**

The Consultant has developed the Project Work Plan and Cost Estimate Schedule (Schedule) that presents a detailed description of the tasks, the estimated labor-hours required, and the total fixed fee to accomplish the analysis. The Schedule is enclosed at the end of this proposal and shows a fixed fee of **\$74,640** inclusive of out-of-pocket expenses.

It is Stantec's practice to invoice monthly based upon the percentage of each task completed. To the extent that additional presentations, meetings, analysis, or any other services are requested by the County that are beyond the scope identified in the above referenced Schedule, they will be completed based upon the actual time required at the hourly rates identified within the Agreement plus actual out-of-pocket expenses, upon authorization by the County.

### **Conclusion**

Stantec is delighted to have the opportunity to present this proposal to you. Please review and if there are any questions or concerns feel free to reach out to me. Stantec has prepared this letter to serve as a short-form agreement in the event the County wishes to immediately proceed with this study. If the terms of this proposal are acceptable, please affix the appropriate signature on the following page and return a copy (a digital scan emailed to me, or facsimile will be acceptable) to us for our files. If you have any questions or would like to discuss this proposal, please do not hesitate to call me call me at (904) 671-0117.

Very truly yours,



Peter Napoli, Senior Manager  
peter.napoli@stantec.com  
Stantec Consulting Services Inc.  
777 S. Harbour Island Boulevard, Suite 600  
Tampa FL 33602-5729



All terms and conditions of the Agreement apply and stay unchanged:

**Accepted by Baker County:**

**Accepted by Stantec Consulting Services Inc.**

Napoli, Peter  
Digitally signed by  
Napoli, Peter  
Date: 2025.12.15 11:27:40  
-05'00'

\_\_\_\_\_  
*Signature*

\_\_\_\_\_  
*Signature*

\_\_\_\_\_  
*Name*

Peter Napoli  
\_\_\_\_\_  
*Name*

\_\_\_\_\_  
*Title*

Manager  
\_\_\_\_\_  
*Title*

\_\_\_\_\_  
*Date*

12/15/2025  
\_\_\_\_\_  
*Date*





**Baker County, Florida**  
**Impact Fee Study**  
**Project Work Plan and Fee Estimate**

Project Tasks	Estimated Labor-Hours					Multiplier (# of Fees Calculated)	Total Labor Hours
	Director	Project Manager	Quality Control	Financial Analyst	Project Admin		
Rates →	\$350	\$275	\$250	\$175	\$120		
<b>Task 1 Initiate the Project, Obtain and Review Relevant Data, and Perform Survey</b>							
a. Prepare initial data request list and detailed critical path schedule. Perform job set up activities. Establish project monitoring and control responsibilities.	0	3	0	6	2	x1	11
b. Conduct kick-off conference call with County staff to confirm study objectives, identify fiscal objectives, establish communication protocols, discuss approach, establish schedule, provide data request, and discuss forecasting methods and modeling.	1	2	0	2	0	x1	5
c. Review the County's Comprehensive Plan (and other docs) to determine adopted level of service standards, population projections, and capital improvement planning elements. Obtain and review fixed asset records for all departments/services.	1	1	0	2	0	x1	4
d. Update population projections based upon census data and permitting and development data and information.	0	1	0	2	0	x1	3
e. Compile property data from County Property Appraiser to identify acreage, sq. ft., dwelling units, etc. by property use type.	0	1	0	2	0	x1	3
f. Perform comparative survey to neighboring and similar communities for fees developed in this study.	0	6	1	16	0	x1	23
<b>Task 2 Calculate Impact Fee for 1 (one) Department/Service</b>							
a. Input level of service, capacity, population, capital improvement plan, fixed asset data, and other key data/assumptions into the model.	0	1	0	1	0	x6	12
b. Input data regarding capital costs recovered via grants, bonds, user fees, and/or taxes for calculation of impact fee credit to avoid "double recovery" of costs in the impact fees and user fees and/or taxes.	0	1	0	1	0	x6	12
c. Identify and input number of ERU's served by CIP and/or Fixed Assets.	0	1	0	1	0	x6	12
d. Finalize customization of impact fee model to determine impact fee rate per ERU.	0	1	0	1	0	x6	12
e. Determine basis of calculating fees for various property use types and develop sample fee calculations for various properties.	0	1	0	1	0	x6	12
f. Conduct internal review with Stantec project team to review preliminary results.	1	1	0	1	0	x6	18
g. Perform adjustments based upon internal review conclusions.	0	1	0	1	0	x6	12
h. Prepare for and conduct a virtual work sessions with County staff to review data and assumptions.	0	1	0	1	0	x6	12
i. Make adjustments to the impact fee model per review with County staff and distribute workbook of results.	1	1	1	1	0	x6	24
j. Assist with implementation considerations, including development of potential phasing and indexing plans.	1	1	0	1	0	x6	18
<b>Task 3 Final Report / Ordinance</b>							
a. Prepare Report of the results of the study, and provide to County staff for review and comment.	4	10	2	20	0	x1	36
b. Prepare schedules of impact fees for inclusion in appropriate ordinance to be prepared by County Attorney.	2	6	0	8	0	x1	16
c. Provide a sample ordinance regarding methodology for calculation of impact fees.	2	4	0	0	0	x1	6
d. Review ordinance prepared by the County's Attorney and provide comments/edits as appropriate.	0	2	0	0	0	x1	2
e. Make adjustments based upon input and direction from County Commission. Complete Final Report and Impact Fee Schedules.	0	6	0	10	0	x1	16





**Baker County, Florida**  
**Impact Fee Study**  
**Project Work Plan and Fee Estimate**

Project Tasks	Estimated Labor-Hours					Multiplier (# of Fees Calculated)	Total Labor Hours
	Director	Project Manager	Quality Control	Financial Analyst	Project Admin		
Rates →	\$350	\$275	\$250	\$175	\$120		
<b>Task 4 Meetings and Presentations</b>							
a. Prepare a presentation of the results of the analyses, including alternative scenarios identified during the project.	1	6	1	8	0	x1	16
b. Meet with the County Management to prepare presentation.	0	3	0	3	0	x1	6
c. Make adjustments based upon input and direction from County management and staff.	1	2	0	4	0	x1	7
d. Present the impact fee results to Board of County Commissioners (2 in person presentations).	0	6	0	0	0	x2	12
<b>SUBTOTAL ESTIMATED LABOR-HOURS TASK 1</b>	2	14	1	30	2		49
<b>SUBTOTAL ESTIMATED LABOR-HOURS TASK 2 (x6 Fees)</b>	18	60	6	60	0		144
<b>SUBTOTAL ESTIMATED LABOR-HOURS TASK 3</b>	8	28	2	38	0		76
<b>SUBTOTAL ESTIMATED LABOR-HOURS TASK 4</b>	2	23	1	15	0		41
<b>TOTAL ESTIMATED LABOR-HOURS</b>	<b>30</b>	<b>125</b>	<b>10</b>	<b>143</b>	<b>2</b>		<b>310</b>
<b>SUBTOTAL ESTIMATED CONSULTING FEE</b>	<b>\$ 10,500</b>	<b>\$ 34,375</b>	<b>\$ 2,500</b>	<b>\$ 25,025</b>	<b>\$ 240</b>		<b>\$ 72,640</b>
<b>ESTIMATED EXPENSES</b>							<b>\$ 2,000</b>
<b>TOTAL NOT-TO-EXCEED CONSULTING FEE</b>							<b>\$ 74,640</b>
<b>ESTIMATED COSTS BY FEE</b>							
TRANSPORTATION IMPACT FEE COST							\$ 12,440
SCHOOLS IMPACT FEE COST							\$ 12,440
PARKS IMPACT FEE COST							\$ 12,440
FIRE RESCUE IMPACT FEE COST							\$ 12,440
EMERGENCY MEDICAL SERVICES IMPACT FEE COST							\$ 12,440
LAW ENFORCEMENT IMPACT FEE COST							\$ 12,440
<b>TOTAL NOT-TO-EXCEED CONSULTING FEE</b>							<b>\$ 74,640</b>
<b>ESTIMATED COSTS BY TASK</b>							
Task 1 Initiate the Project, Obtain and Review Relevant Data, and Perform Survey							\$ 11,798
Task 2 Calculate Impact Fee for 1 (one) Department/Service (x6 Impact Fees)							\$ 34,671
Task 3 Final Report / Ordinance							\$ 18,299
Task 4 Meetings and Presentations							\$ 9,872
<b>TOTAL NOT-TO-EXCEED CONSULTING FEE</b>							<b>\$ 74,640</b>



The following Terms and Conditions are attached to and form part of a proposal for services to be performed by Consultant and together, when the CLIENT authorizes Consultant to proceed with the services, constitute the AGREEMENT. Consultant means the Stantec entity issuing the Proposal.

**DESCRIPTION OF WORK:** Consultant shall render the services described in the Proposal (hereinafter called the "SERVICES") to the CLIENT.

**DESCRIPTION OF CLIENT:** The CLIENT confirms and agrees that the CLIENT has authority to enter into this AGREEMENT on its own behalf and on behalf of all parties related to the CLIENT who may have an interest in the PROJECT.

**TERMS AND CONDITIONS:** No terms, conditions, understandings, or agreements purporting to modify or vary these Terms and Conditions shall be binding unless hereafter made in writing and signed by the CLIENT and Consultant. In the event of any conflict between the Proposal and these Terms and Conditions, these Terms and Conditions shall take precedence. This AGREEMENT supercedes all previous agreements, arrangements or understandings between the parties whether written or oral in connection with or incidental to the PROJECT

**COMPENSATION:** Payment is due to Consultant upon receipt of invoice. Failure to make any payment when due is a material breach of this AGREEMENT and will entitle Consultant, at its option, to suspend or terminate this AGREEMENT and the provision of the SERVICES. Interest will accrue on accounts overdue by 30 days at the lesser of 1.5 percent per month (18 percent per annum) or the maximum legal rate of interest. Unless otherwise noted, the fees in this agreement do not include any value added, sales, or other taxes that may be applied by Government on fees for services. Such taxes will be added to all invoices as required.

**NOTICES:** Each party shall designate a representative who is authorized to act on behalf of that party. All notices, consents, and approvals required to be given hereunder shall be in writing and shall be given to the representatives of each party.

**TERMINATION:** Either party may terminate the AGREEMENT without cause upon thirty (30) days notice in writing. If either party breaches the AGREEMENT and fails to remedy such breach within seven (7) days of notice to do so by the non-defaulting party, the non-defaulting party may immediately terminate the Agreement. Non-payment by the CLIENT of Consultant's invoices within 30 days of Consultant rendering same is agreed to constitute a material breach and, upon written notice as prescribed above, the duties, obligations and responsibilities of Consultant are terminated. On termination by either party, the CLIENT shall forthwith pay Consultant all fees and charges for the SERVICES provided to the effective date of termination.

**ENVIRONMENTAL:** Except as specifically described in this AGREEMENT, Consultant's field investigation, laboratory testing and engineering recommendations will not address or evaluate pollution of soil or pollution of groundwater.

**PROFESSIONAL RESPONSIBILITY:** In performing the SERVICES, Consultant will provide and exercise the standard of care, skill and diligence required by customarily accepted professional practices normally provided in the performance of the SERVICES at the time and the location in which the SERVICES were performed.

**LIMITATION OF LIABILITY:** The CLIENT releases Consultant from any liability and agrees to defend, indemnify and hold Consultant harmless from any and all claims, damages, losses, and/or expenses, direct and indirect, or consequential damages, including but not limited to attorney's fees and charges and court and arbitration costs, arising out of, or claimed to arise out of, the performance of the SERVICES, excepting liability arising from the sole negligence of Consultant. It is further agreed that the total amount of all claims the CLIENT may have against Consultant under this AGREEMENT, including but not limited to claims for negligence, negligent misrepresentation and/or breach of contract, shall be strictly limited to the lesser of professional fees paid to Consultant for the SERVICES or \$50,000.00. No claim may be brought against Consultant more than two (2) years after the cause of action arose. As the CLIENT's sole and exclusive remedy under this AGREEMENT any claim, demand or suit shall be directed and/or asserted only against Consultant and not against any of Consultant's employees, officers or directors.

Consultant's liability with respect to any claims arising out of this AGREEMENT shall be absolutely limited to direct damages arising out of the SERVICES and Consultant shall bear no liability whatsoever for any consequential loss, injury or damage incurred by the CLIENT, including but not limited to claims for loss of use, loss of profits and/or loss of markets.

**INDEMNITY FOR MOLD CLAIMS:** It is understood by the parties that existing or constructed buildings may contain mold substances that can present health hazards and result in bodily injury, property damage and/or necessary remedial measures. If, during performance of the SERVICES, Consultant knowingly encounters any such substances, Consultant shall notify the CLIENT and, without liability for consequential or any other damages, suspend performance of services until the CLIENT retains a qualified specialist to abate and/or remove the mold substances. The CLIENT agrees to release and waive all claims, including consequential damages, against Consultant, its subconsultants and their officers, directors and employees arising from or in any way connected with the existence of mold on or about the project site whether during or after completion of the SERVICES. The CLIENT further agrees to indemnify and hold Consultant harmless from and against all claims, costs, liabilities and damages, including reasonable attorneys' fees and costs, arising in any way from the existence of mold on the project site whether during or after completion of the SERVICES, except for those claims, liabilities, costs or damages caused by the sole gross negligence and/or knowing or willful misconduct of Consultant. Consultant and the CLIENT waive all rights against each other for mold damages to the extent that such damages sustained by either party are covered by insurance.

**DOCUMENTS:** All of the documents prepared by or on behalf of Consultant in connection with the PROJECT are instruments of service for the execution of the PROJECT. Consultant retains the property and copyright in these documents, whether the PROJECT is executed or not. These documents may not be used for any other purpose without the prior written consent of Consultant. In the event Consultant's documents are subsequently reused or modified in any material respect without the prior consent of Consultant, the CLIENT agrees to defend, hold harmless and indemnify Consultant from any claims advanced on account of said reuse or modification.

Any document produced by Consultant in relation to the Services is intended for the sole use of Client. The documents may not be relied upon by any other party without the express written consent of Consultant, which may be withheld at Consultant's discretion. Any such consent will provide no greater rights to the third party than those held by the Client under the contract, and will only be authorized pursuant to the conditions of Consultant's standard form reliance letter.

Consultant cannot guarantee the authenticity, integrity or completeness of data files supplied in electronic format ("Electronic Files"). CLIENT shall release, indemnify and hold Consultant, its officers, employees, Consultant's and agents harmless from any claims or damages arising from the use of Electronic Files. Electronic files will not contain stamps or seals, remain the property of Consultant, are not to be used for any purpose other than that for which they were transmitted, and are not to be retransmitted to a third party without Consultant's written consent.

**FIELD SERVICES:** Consultant shall not be responsible for construction means, methods, techniques, sequences or procedures, or for safety precautions and programs in connection with work on the PROJECT, and shall not be responsible for any contractor's failure to carry out the work in accordance with the contract documents. Consultant shall not be responsible for the acts or omissions of any contractor, subcontractor, any of their agents or employees, or any other persons performing any of the work in connection with the PROJECT. Consultant shall not be the prime contractor or similar under any occupational health and safety legislation.

**GOVERNING LAW/COMPLIANCE WITH LAWS:** The AGREEMENT shall be governed, construed and enforced in accordance with the laws of the jurisdiction in which the majority of the SERVICES are performed. Consultant shall observe and comply with all applicable laws, continue to provide equal employment opportunity to all qualified persons, and to recruit, hire, train, promote and compensate persons in all jobs without regard to race, color, religion, sex, age, disability or national origin or any other basis prohibited by applicable laws.

**DISPUTE RESOLUTION:** If requested in writing by either the CLIENT or Consultant, the CLIENT and Consultant shall attempt to resolve any dispute between them arising out of or in connection with this AGREEMENT by entering into structured non-binding negotiations with the assistance of a mediator on a without prejudice basis. The mediator shall be appointed by agreement of the parties. If a dispute cannot be settled within a period of thirty (30) calendar days with the mediator, if mutually agreed, the dispute shall be referred to arbitration pursuant to laws of the jurisdiction in which the majority of the SERVICES are performed or elsewhere by mutual agreement.

**ASSIGNMENT:** The CLIENT and Consultant shall not, without the prior written consent of the other party, assign the benefit or in any way transfer the obligations under these Terms and Conditions or any part hereof.

**SEVERABILITY:** If any term, condition or covenant of the AGREEMENT is held by a court of competent jurisdiction to be invalid, void, or unenforceable, the remaining provisions of the AGREEMENT shall be binding on the CLIENT and Consultant.

**FLORIDA CONTRACTS: PURSUANT TO FLORIDA STATUTES CHAPTER 558.0035 AN INDIVIDUAL EMPLOYEE OR AGENT MAY NOT BE HELD INDIVIDUALLY LIABLE FOR DAMAGES RESULTING FROM NEGLIGENCE.**

April 1, 2026

**VIA EMAIL ONLY**

Sara Little, County Manager  
Baker County, Florida  
55 North 3rd Street  
Macclenny, FL 32063

Re: Professional Services Related to Revenue Sufficiency Analysis for Existing Solid Waste Assessment Program and Implementation of Program Modifications

Dear Ms. Little:

Thank you for considering Bryant Miller Olive (the "Firm") for purposes of assisting Baker County (the "County") with a revenue sufficiency analysis for the County's existing solid waste assessment program. As further described in the scope of services description below, our assistance will include the revenue sufficiency analysis, presenting the County with recommendations concerning updates and/or modifications to the solid waste assessments resulting from the analysis, and assisting the County with implementing such recommendations. The Firm has extensive experience in this field, and we would be pleased to provide related professional services to the County. This letter sets forth the terms by which the Firm will provide such services.

At the outset we note that accomplishing the County's objectives will necessarily require more than legal expertise. We propose collaborating with the Stantec consulting firm (the "Methodology Consultant") which will, among other things conduct the revenue sufficiency analysis. In the engagement, the Firm will have an attorney-client relationship with the County and will collaborate with the Methodology Consultant as a sub-consultant hereunder.

The anticipated scope of services for development and implementation of solid waste assessments is outlined below, and additional detail is included in the Methodology Consultant's proposal attached hereto as Exhibit "A".

1. Analyzing the County's existing solid waste assessment program and rate structure to determine its sufficiency for meeting current and future funding needs; recommending updates and/or modifications to the assessment program; preparing a written report or study summarizing the analysis and recommendations.

2. Drafting ordinances and/or resolutions to adopt and implement recommended modifications to the existing solid waste assessment program necessary to achieve the County's rate sufficiency objectives; drafting related notices.
3. Research and advice regarding state law governing assessments and any changes or updates thereto.
4. Preparing written memoranda when necessary.
5. Appearing at County meetings to present the results of the revenue sufficiency analysis and recommendations regarding the solid waste assessment program, and to assist with the process of implementing any recommended modifications.

#### **FEES AND EXPENSES**

I will be the attorney primarily responsible for the legal aspects of the work effort. The County will be billed for my time at my standard hourly rate of \$350.00 per hour. As appropriate, certain tasks may be assigned to associates and paralegals. Work performed by associates will be billed at \$275.00 per hour, and work performed by paralegals will be billed at \$125.00 per hour, respectively. We estimate that the legal fees will not exceed a total of \$14,000. In addition, the Methodology Consultant will charge a fixed fee of \$35,160 as outlined in their attached proposal. The cost estimates summarized above are for professional fees only.

While the cost estimates set forth above are conservative and actual costs may be less in light of cost-efficiencies, the direction of the County will control and matters of outside influence beyond the control of the County and/or the Firm may impact the anticipated work effort.

In addition to hourly rates, the Firm will invoice for reimbursement for actual costs incurred, such as computer printing or photocopies, long distance telephone charges and travel expenses which will be reimbursed in accordance with Section 112.061, Florida Statutes. For budgeting purposes, reimbursements for actual costs are not expected to exceed 2% of the professional fees. We will bill periodically, but not less often than monthly, by detailed invoice reflecting hours and expenses with all appropriate back-up materials typically required by governmental entities.

The County may cancel or terminate this engagement at any time upon written notice to the Firm. In the event of termination of this engagement, the Firm and Methodology Consultant will immediately cease work and shall be reimbursed for eligible and documented time and reimbursable expenses incurred prior to the notice to stop work.

Sara Little  
Baker County, Florida  
April 1, 2026  
Page 3 of 3

If the terms and conditions described in this letter are acceptable, please direct us to proceed by returning a signed copy for our files. We look forward to working with you and greatly appreciate this opportunity to serve Baker County.

Sincerely,



Christopher B. Roe, Shareholder

cc: Richard Komando, County Attorney  
Peter Napoli, Stantec

Direction to proceed this \_\_\_\_\_ day of \_\_\_\_\_, 2026:

By: \_\_\_\_\_

Print: \_\_\_\_\_

Title: \_\_\_\_\_

**EXHIBIT "A"**

**STANTEC PROPOSAL**



January 14, 2026

Sara Little, County Manager  
Baker County Administration  
55 North Third Street  
Macclenny, FL 32063  
(904) 259-3613

Re: Baker County Solid Waste Assessment Study

Dear Ms. Little:

Stantec has prepared the following proposal to conduct the above-mentioned Solid Waste Assessment Study (Study) for Baker County.

### **Project Description**

Stantec has prepared this proposal to conduct a Solid Waste Assessment Study in which we would perform an analysis of the County's Solid Waste assessment program to evaluate the sufficiency of revenues and verify the cost allocation is appropriate. In our 30+ years of experience, we have developed a thorough and effective approach to the development, review, and update of non-ad valorem assessment rate studies. Our understanding of non-ad valorem assessment statutes, "case law", and legislation will provide the County with the essentials to design and adopt a fair and reasonable solid waste rate structure which meets the financial requirements and legal obligations of the County.

### **Scope of Services**

#### **Initiate the Project, Obtain and Review Relevant Data**

To begin the solid waste rate study, we will meet with County staff in a virtual planning meeting to discuss the current funding methodology, data requirements, timeline, and specific County objectives.

#### **Calculation of Solid Waste Assessments**

Once we have reviewed and discussed all data in detail, we will prepare a ten-year financial plan for the funding of solid waste services. We will leverage our interactive financial model to develop alternative scenarios that will truly integrate the capital and financial planning processes. We will analyze current and historical budgets to determine the revenue requirements for current and future level of services that recovers the cost of operations, equipment/capital improvements, implementation, and collection.

We will then develop fees using the revenue requirements developed in the financial plan, the County's waste stream and operations data, and the summary property data as maintained by the Baker County Property Appraiser. As part of the solid waste rate development, we will populate our rate/fee model with the necessary operational data to apportion costs and explore alternatives. These alternatives will be



reviewed in a virtual work session with County staff and will include evaluation of the impact of the rate/fee options on residential property owners.

### **Presentations and Deliverables**

Upon completion of the analyses, Stantec will prepare a presentation of the results, review the presentation with you, and present the resulting proposed fees to the County Commission in two (2) meetings. Stantec will incorporate any adjustments to the analyses necessary based upon input from the County Commission and prepare a draft report for your review and comment. Stantec will incorporate any comments and prepare and deliver a Final Report including the underlying assumptions and methodologies used for each of the impact fee categories.

### **Time of Performance**

Stantec proposes to begin the Study upon receipt of a notice-to-proceed from the County. The study will be completed within 150 days of receipt of all requested data. This schedule is contingent upon County staff availability for meetings and responsiveness to review draft deliverables.

### **Consultant's Compensation**

Stantec has developed the Project Work Plan and Cost Estimate Schedule (Schedule) that presents a detailed description of the tasks, the estimated labor-hours required, and the total fixed fee to accomplish the analysis. The Schedule is enclosed at the end of this proposal and shows a fixed fee of **\$35,160** inclusive of out-of-pocket expenses.

It is Stantec's practice to invoice monthly based upon the percentage of each task completed. To the extent that additional presentations, meetings, analysis, or any other services are requested by the County that are beyond the scope identified in the above referenced Schedule, they will be completed based upon the actual time required at the hourly rates identified within the Agreement plus actual out-of-pocket expenses, upon authorization by the County.

### **Conclusion**

Stantec is delighted to have the opportunity to present this proposal to you. Please review and if there are any questions or concerns feel free to reach out to me. Stantec has prepared this letter to serve as a short-form agreement in the event the County wishes to immediately proceed with this study. If the terms of this proposal are acceptable, please affix the appropriate signature on the following page and return a copy (a digital scan emailed to me, or facsimile will be acceptable) to us for our files. If you have any questions or would like to discuss this proposal, please do not hesitate to call me at (904) 671-0117.

Very truly yours,



Peter Napoli, Senior Manager  
peter.napoli@stantec.com  
Stantec Consulting Services Inc.  
777 S. Harbour Island Boulevard, Suite 600  
Tampa FL 33602-5729



All terms and conditions of the Agreement apply and stay unchanged:

**Accepted by Baker County:**

\_\_\_\_\_  
*Signature*

\_\_\_\_\_  
*Name*

\_\_\_\_\_  
*Title*

\_\_\_\_\_  
*Date*

**Accepted by Stantec Consulting Services Inc.**

**Napoli, Peter** Digitally signed by Napoli, Peter  
Date: 2026.01.14 08:38:24 -05'00'

\_\_\_\_\_  
*Signature*

**Peter Napoli**  
\_\_\_\_\_  
*Name*

**Senior Manager**  
\_\_\_\_\_  
*Title*

**1/14/2026**  
\_\_\_\_\_  
*Date*





**Baker County, FL**  
**FY 2026 Solid Waste Rate Study Update**  
**Project Work Plan and Fee Estimate**

Project Tasks	Estimated Labor-Hours					Total Project
	Project Director	Quality Control	Project Manager	Financial Analyst	Project Admin	
Rates	\$350	\$250	\$275	\$175	\$120	
<b>Task 1 Initiate the Project, Obtain and Review Relevant Data</b>						
a. Prepare initial data request list and detailed critical path schedule, perform job set up activities, and establish project monitoring and control responsibilities.	0	0	3	3	3	9
b. Conduct virtual work session with County staff to confirm study objectives, identify fiscal objectives, establish communication protocols, discuss approach, establish schedule, provide data request, and discuss forecasting methods and modeling.	1	1	1	1	0	4
c. Gather and review items from initial data request list. Identify, source, and obtain all required data/information. This will occur through initial and supplemental data requests to be delivered during this task.	0	0	2	4	0	6
d. Conduct a solid waste assessment benchmarking survey to review up to 8 neighboring and similar community residential solid waste assessment rates, structure and funding.	0	0	1	5	0	6
<b>Task 2 Calculation of Solid Waste Assessments</b>						
a. Evaluate the County's existing legal documents, agreements, reports and other data pertaining to the provision of solid waste services.	0	0	1	6	0	7
b. Perform a detailed analysis of the County's provision of Solid Waste Services including operations, waste stream analysis, and tonnage data in order to develop an appropriate apportionment methodology.	0	1	1	6	0	8
c. Evaluate the County's Solid Waste Services current fiscal year budget and equipment expenditure/capital plan for FY 2026 - FY 2035 to determine the full cost of providing solid waste services.	0	0	1	6	0	7
d. Determine the net service delivery revenue requirements for current and future level of services. Isolate the costs as appropriate relating to the provision of solid waste services and create a ten-year projected revenue requirement for current and future level of services and to maintain and/or update equipment as needed. This will include the costs associated with implementing the study update and collection of the new rates/fees.	0	0	1	6	0	7
e. Develop the proposed solid waste rate/fee model utilizing the latest summary property data files, waste stream and tonnage data analysis results and net assessable budget.	0	0	1	6	0	7
f. Revise the methodology and adjust the proposed model as necessary to determine legally available options to be considered by the County.	0	0	1	6	0	7
g. Conduct Internal Review with Project team to review preliminary results.	3	3	3	3	0	12
h. Conduct Virtual Work Session with County Staff to review preliminary model results.	0	0	2	2	0	4
i. Make adjustments based upon interactive work session and update model with latest information available.	0	0	3	6	0	9
j. Conduct Internal Review with Project team to review final results.	0	0	1	1	0	2
k. Develop a pro forma schedule of rates based on the apportionment methodology and revenue requirements for Solid Waste Services including, but not limited to, personnel, administration, equipment, capital projects and assessment program implementation, collection and administration.	1	1	2	4	0	8
l. Conduct Virtual Work Session with County Staff & Management to review final results.	0	0	2	2	0	4
<b>Task 3 Review Results with County Management and County Commission</b>						
a. Prepare and deliver Draft Report for County Staff & Management review.	1	1	4	7	0	13
b. Prepare presentation for Commission workshop, provide to County staff for review, adjust accordingly.	1	1	4	6	0	12
c. Present the results of the analysis to Commission in-person at a workshop.	0	0	6	0	0	6
d. Make adjustments based upon feedback/direction from the Commission workshop.	1	1	2	4	0	8
e. Deliver Final Report, documenting results of the study, to the County.	1	1	1	1	0	4
f. Present the final results of the study to the County Commission in person at a Commission meeting and/or workshop as requested by the County.	0	0	6	0	0	6
<b>SUBTOTAL ESTIMATED LABOR-HOURS</b>	<b>9</b>	<b>10</b>	<b>49</b>	<b>85</b>	<b>3</b>	<b>156</b>
<b>SUBTOTAL ESTIMATED PROJECT FEE</b>	<b>\$ 3,150</b>	<b>\$ 2,500</b>	<b>\$ 13,475</b>	<b>\$ 14,875</b>	<b>\$ 360</b>	<b>\$ 34,360</b>
<b>ESTIMATED EXPENSES</b>						<b>\$ 800</b>
<b>TOTAL ESTIMATED FIXED FEE</b>						<b>\$ 35,160</b>



The following Terms and Conditions are attached to and form part of a proposal for services to be performed by Consultant and together, when the CLIENT authorizes Consultant to proceed with the services, constitute the AGREEMENT. Consultant means the Stantec entity issuing the Proposal.

**DESCRIPTION OF WORK:** Consultant shall render the services described in the Proposal (hereinafter called the "SERVICES") to the CLIENT.

**DESCRIPTION OF CLIENT:** The CLIENT confirms and agrees that the CLIENT has authority to enter into this AGREEMENT on its own behalf and on behalf of all parties related to the CLIENT who may have an interest in the PROJECT.

**TERMS AND CONDITIONS:** No terms, conditions, understandings, or agreements purporting to modify or vary these Terms and Conditions shall be binding unless hereafter made in writing and signed by the CLIENT and Consultant. In the event of any conflict between the Proposal and these Terms and Conditions, these Terms and Conditions shall take precedence. This AGREEMENT supercedes all previous agreements, arrangements or understandings between the parties whether written or oral in connection with or incidental to the PROJECT

**COMPENSATION:** Payment is due to Consultant upon receipt of invoice. Failure to make any payment when due is a material breach of this AGREEMENT and will entitle Consultant, at its option, to suspend or terminate this AGREEMENT and the provision of the SERVICES. Interest will accrue on accounts overdue by 30 days at the lesser of 1.5 percent per month (18 percent per annum) or the maximum legal rate of interest. Unless otherwise noted, the fees in this agreement do not include any value added, sales, or other taxes that may be applied by Government on fees for services. Such taxes will be added to all invoices as required.

**NOTICES:** Each party shall designate a representative who is authorized to act on behalf of that party. All notices, consents, and approvals required to be given hereunder shall be in writing and shall be given to the representatives of each party.

**TERMINATION:** Either party may terminate the AGREEMENT without cause upon thirty (30) days notice in writing. If either party breaches the AGREEMENT and fails to remedy such breach within seven (7) days of notice to do so by the non-defaulting party, the non-defaulting party may immediately terminate the Agreement. Non-payment by the CLIENT of Consultant's invoices within 30 days of Consultant rendering same is agreed to constitute a material breach and, upon written notice as prescribed above, the duties, obligations and responsibilities of Consultant are terminated. On termination by either party, the CLIENT shall forthwith pay Consultant all fees and charges for the SERVICES provided to the effective date of termination.

**ENVIRONMENTAL:** Except as specifically described in this AGREEMENT, Consultant's field investigation, laboratory testing and engineering recommendations will not address or evaluate pollution of soil or pollution of groundwater.

**PROFESSIONAL RESPONSIBILITY:** In performing the SERVICES, Consultant will provide and exercise the standard of care, skill and diligence required by customarily accepted professional practices normally provided in the performance of the SERVICES at the time and the location in which the SERVICES were performed.

**LIMITATION OF LIABILITY:** The CLIENT releases Consultant from any liability and agrees to defend, indemnify and hold Consultant harmless from any and all claims, damages, losses, and/or expenses, direct and indirect, or consequential damages, including but not limited to attorney's fees and charges and court and arbitration costs, arising out of, or claimed to arise out of, the performance of the SERVICES, excepting liability arising from the sole negligence of Consultant. It is further agreed that the total amount of all claims the CLIENT may have against Consultant under this AGREEMENT, including but not limited to claims for negligence, negligent misrepresentation and/or breach of contract, shall be strictly limited to the lesser of professional fees paid to Consultant for the SERVICES or \$50,000.00. No claim may be brought against Consultant more than two (2) years after the cause of action arose. As the CLIENT's sole and exclusive remedy under this AGREEMENT any claim, demand or suit shall be directed and/or asserted only against Consultant and not against any of Consultant's employees, officers or directors.

Consultant's liability with respect to any claims arising out of this AGREEMENT shall be absolutely limited to direct damages arising out of the SERVICES and Consultant shall bear no liability whatsoever for any consequential loss, injury or damage incurred by the CLIENT, including but not limited to claims for loss of use, loss of profits and/or loss of markets.

**INDEMNITY FOR MOLD CLAIMS:** It is understood by the parties that existing or constructed buildings may contain mold substances that can present health hazards and result in bodily injury, property damage and/or necessary remedial measures. If, during performance of the SERVICES, Consultant knowingly encounters any such substances, Consultant shall notify the CLIENT and, without liability for consequential or any other damages, suspend performance of services until the CLIENT retains a qualified specialist to abate and/or remove the mold substances. The CLIENT agrees to release and waive all claims, including consequential damages, against Consultant, its subconsultants and their officers, directors and employees arising from or in any way connected with the existence of mold on or about the project site whether during or after completion of the SERVICES. The CLIENT further agrees to indemnify and hold Consultant harmless from and against all claims, costs, liabilities and damages, including reasonable attorneys' fees and costs, arising in any way from the existence of mold on the project site whether during or after completion of the SERVICES, except for those claims, liabilities, costs or damages caused by the sole gross negligence and/or knowing or willful misconduct of Consultant. Consultant and the CLIENT waive all rights against each other for mold damages to the extent that such damages sustained by either party are covered by insurance.

**DOCUMENTS:** All of the documents prepared by or on behalf of Consultant in connection with the PROJECT are instruments of service for the execution of the PROJECT. Consultant retains the property and copyright in these documents, whether the PROJECT is executed or not. These documents may not be used for any other purpose without the prior written consent of Consultant. In the event Consultant's documents are subsequently reused or modified in any material respect without the prior consent of Consultant, the CLIENT agrees to defend, hold harmless and indemnify Consultant from any claims advanced on account of said reuse or modification.

Any document produced by Consultant in relation to the Services is intended for the sole use of Client. The documents may not be relied upon by any other party without the express written consent of Consultant, which may be withheld at Consultant's discretion. Any such consent will provide no greater rights to the third party than those held by the Client under the contract, and will only be authorized pursuant to the conditions of Consultant's standard form reliance letter.

Consultant cannot guarantee the authenticity, integrity or completeness of data files supplied in electronic format ("Electronic Files"). CLIENT shall release, indemnify and hold Consultant, its officers, employees, Consultant's and agents harmless from any claims or damages arising from the use of Electronic Files. Electronic files will not contain stamps or seals, remain the property of Consultant, are not to be used for any purpose other than that for which they were transmitted, and are not to be retransmitted to a third party without Consultant's written consent.

**FIELD SERVICES:** Consultant shall not be responsible for construction means, methods, techniques, sequences or procedures, or for safety precautions and programs in connection with work on the PROJECT, and shall not be responsible for any contractor's failure to carry out the work in accordance with the contract documents. Consultant shall not be responsible for the acts or omissions of any contractor, subcontractor, any of their agents or employees, or any other persons performing any of the work in connection with the PROJECT. Consultant shall not be the prime contractor or similar under any occupational health and safety legislation.

**GOVERNING LAW/COMPLIANCE WITH LAWS:** The AGREEMENT shall be governed, construed and enforced in accordance with the laws of the jurisdiction in which the majority of the SERVICES are performed. Consultant shall observe and comply with all applicable laws, continue to provide equal employment opportunity to all qualified persons, and to recruit, hire, train, promote and compensate persons in all jobs without regard to race, color, religion, sex, age, disability or national origin or any other basis prohibited by applicable laws.

**DISPUTE RESOLUTION:** If requested in writing by either the CLIENT or Consultant, the CLIENT and Consultant shall attempt to resolve any dispute between them arising out of or in connection with this AGREEMENT by entering into structured non-binding negotiations with the assistance of a mediator on a without prejudice basis. The mediator shall be appointed by agreement of the parties. If a dispute cannot be settled within a period of thirty (30) calendar days with the mediator, if mutually agreed, the dispute shall be referred to arbitration pursuant to laws of the jurisdiction in which the majority of the SERVICES are performed or elsewhere by mutual agreement.

**ASSIGNMENT:** The CLIENT and Consultant shall not, without the prior written consent of the other party, assign the benefit or in any way transfer the obligations under these Terms and Conditions or any part hereof.

**SEVERABILITY:** If any term, condition or covenant of the AGREEMENT is held by a court of competent jurisdiction to be invalid, void, or unenforceable, the remaining provisions of the AGREEMENT shall be binding on the CLIENT and Consultant.

**FLORIDA CONTRACTS: PURSUANT TO FLORIDA STATUTES CHAPTER 558.0035 AN INDIVIDUAL EMPLOYEE OR AGENT MAY NOT BE HELD INDIVIDUALLY LIABLE FOR DAMAGES RESULTING FROM NEGLIGENCE.**



## BAKER COUNTY BOARD OF COUNTY COMMISSIONERS AGENDA ITEM REQUEST FORM

The Board of County Commissioners meet on the 1<sup>st</sup> and 3<sup>rd</sup> Tuesday of each month at 5:00 p.m. at the Baker County Administration Office, Commission Chambers, 55 North Third Street, Macclenny, FL 32063. All agenda items should be submitted to County Administration via [sara.little@bakercountyfl.org](mailto:sara.little@bakercountyfl.org) and [kayla.riggs@bakercountyfl.org](mailto:kayla.riggs@bakercountyfl.org) no later than the Wednesday prior to the Commission meeting.

Date of Submission: 03/03/2026 Meeting Date: 04/07/2026

Name of Submitter: Brooklyn Nevill Department: Finance

1. Nature and purpose of this agenda item:

Propose amendments to 2025/2026 budget that was originally approved on 9/23/2025.

2. Recommended Motion/Action:

Review and approve amended budget

3. Will this item require a presentation? No, but I have a printed handout for the board.

4. Deadline for Completion: 04/07/2026

5. Fiscal Impact Questions:

Is this item included in the current budget? Yes

If item is grant related, is there a County match requirement? N/A

Explain the procurement process for this request (attach necessary documentation): N/A

**RESOLUTION 2026-07**

**A RESOLUTION OF THE BOARD OF COUNTY COMMISSIONERS OF BAKER COUNTY, FLORIDA, ADOPTING AN AMENDMENT OF THE BUDGET FOR FISCAL YEAR 2025/2026 PROVIDING FOR AN EFFECTIVE DATE.**

**WHEREAS**, the Board of County Commissioners of Baker County, Florida, set forth the appropriations and revenue estimate for the budget amendment for Fiscal Year 2025/2026 for the purpose of updating revenues and expenditures to reflect current year activity and previous years' trends.

**NOW, THEREFORE, BE IT RESOLVED** by the Board of County Commissioners of Baker County, Florida, that:

1. The Fiscal Year 2025/2026 Budget Amendment be adopted.
2. This resolution shall take effect immediately upon its adoption.

Approved and resolved on the 7<sup>th</sup> day of April 2026, by the Baker County Board of County Commissioners.

**BOARD OF COUNTY COMMISSIONERS OF  
BAKER COUNTY, FLORIDA**

---

Ronald Mann, Chairman

**Attest:**

---

Stacie D. Harvey, Clerk to the Board

**BAKER COUNTY DEPARTMENTAL BUDGET (APPROVED ON 9/23/2025)**

**GENERAL FUND (001)**

FISCAL YEAR 2025-2026

BUDGET CATEGORY	24/25	ACTUALS	CURRENT YEAR	BUDGET VS PRIOR
			BUDGET	YEAR ACTUAL
REVENUES		16,409,780	14,096,743	(2,313,037)
TRANSFERS IN		191,203	208,000	16,797
LESS: 5%		(830,049)	(724,905)	105,144
<b>TOTAL REVENUES</b>		<b>15,770,934</b>	<b>13,579,838</b>	<b>(2,191,096)</b>
<b>CASH FORWARD</b>		<b>21,680,848</b>	<b>3,849,785</b>	
<b>TOTAL BUDGET</b>		<b>37,451,781</b>	<b>17,429,623</b>	
PERSONAL SERVICES		4,758,764	5,571,323	812,559
OPERATING COSTS		3,254,859	9,820,461	6,565,602
EQUIPMENT		148,790	513,870	365,080
TRANSFERS OUT		7,059,985	8,108,609	1,048,624
<b>TOTAL EXPENDITURES</b>		<b>15,222,397</b>	<b>24,014,263</b>	<b>8,791,865</b>
ENDING FUND BALANCE		22,229,384	(6,584,640)	
<b>TOTAL BUDGET</b>		<b>37,451,781</b>	<b>17,429,623</b>	
<b>Revenues - expenses (decrease in fund balance):</b>				<b>(10,434,424.73)</b>

**BAKER COUNTY BOARD OF COUNTY COMMISSIONERS**

**BUDGET PRESENTATION 9/23/2025**

FUND	DESCRIPTION	INCOME	EXPENSE	DIFFERENCES
001	<b>GENERAL FUND</b>	<b>17,429,623</b>	<b>17,429,623</b>	<b>0</b>
103	PUBLIC WORKS	4,815,078	4,815,078	0
104	FINE & FORFEITURE FUND	13,698,853	13,698,853	0
105	FIRE DEPARTMENT FUND	3,130,109	3,130,109	0
108	EMS GRANT FUND	75,000	75,000	0
110	HEALTH REIMBURSEMENT FUND	200,000	200,000	0
111	TDC- TOURIST DEV. COMM. FUND	700,000	700,000	0
112	LAW LIBRARY TRUST FUND	9,500	9,500	0
113	LEGAL AID TRUST FUND	9,500	9,500	0
114	JUVENILE TRUST FUND	9,500	9,500	0
115	CRIME PREVENTION T.F.	12,550	12,550	0
116	<b>SOLID WASTE</b>	<b>1,203,630</b>	<b>1,203,630</b>	<b>0</b>
117	ALCOHOL/DRUG ABUSE TRUST	750	750	0
119	COURT FACILITY FUND	188,500	188,500	0
120	DRIVERS ED TRUST FUND	7,500	7,500	0
121	SPECIAL LAW ENFORCEMENT	45,000	45,000	0
122	SHIP FUND	517,537	517,537	0
123	SHOALS PARK	306,570	306,570	0
133	BOATING IMPROVEMENT FUND	208,105	208,105	0
139	COURT INNOVATIONS TRUST	246,000	246,000	0
166	12.50 SC FUND	66,500	66,500	0
180	IMPACT FEE TRUST FUND	3,300	3,300	0
197	PARAMEDICINE GRANT	361,609	361,609	0
201	LATCF - LOCAL ASSISTANCE TRIBAL	510,885	510,885	0
255	NATIONAL FOREST/TITLE III-FIREWISE	145,784	145,784	0
600	ROAD PAVING FUND	5,475,125	5,475,125	0
		<b>49,376,508</b>	<b>49,376,508</b>	<b>0</b>

**SUPPLEMENTAL BUDGET AMENDMENT WORKSHEET**  
**GENERAL FUND (001)**  
**FISCAL YEAR 2025-2026**

BUDGET CATEGORY	24/25	CURRENT YEAR		BUDGET VS PRIOR YEAR
		ACTUALS	BUDGET	ACTUAL
REVENUES		16,409,780	15,172,217	(1,237,563)
TRANSFERS IN		191,203	208,000	16,797
LESS: 5%		(830,049)	(769,011)	61,038
<b>TOTAL REVENUES</b>		<b>15,770,934</b>	<b>14,611,206</b>	<b>(1,159,727)</b>
<b>BEGINNING FUND BALANCE</b>		<b>21,680,848</b>	<b>23,059,433</b>	
<b>TOTAL BUDGET</b>		<b>37,451,781</b>	<b>37,670,639</b>	
PERSONAL SERVICES		5,174,024	5,164,337	(9,687)
OPERATING COSTS		5,757,315	6,286,361	529,046
EQUIPMENT		148,790	146,730	(2,060)
TRANSFERS OUT		4,142,269	7,876,107	3,733,838
<b>TOTAL EXPENDITURES</b>		<b>15,222,397</b>	<b>19,473,535</b>	<b>4,251,137</b>
ENDING FUND BALANCE		22,229,384	18,197,104	
<b>TOTAL BUDGET</b>		<b>37,451,781</b>	<b>37,670,639</b>	
<b>Revenues - expenses (decrease in fund balance):</b>				<b>(4,862,328.57)</b>

\*\*NOTE\*\*

Previously, the "CASH FORWARD" method was used to appropriate a portion of the fund balance for use. I thought it more transparent to use actual Fund Balance to give the board and public a more transparent figure of what we have available to spend.

GENERAL FUND (001) CHARTS

GENERAL FUND (001) BUDGET REVENUE

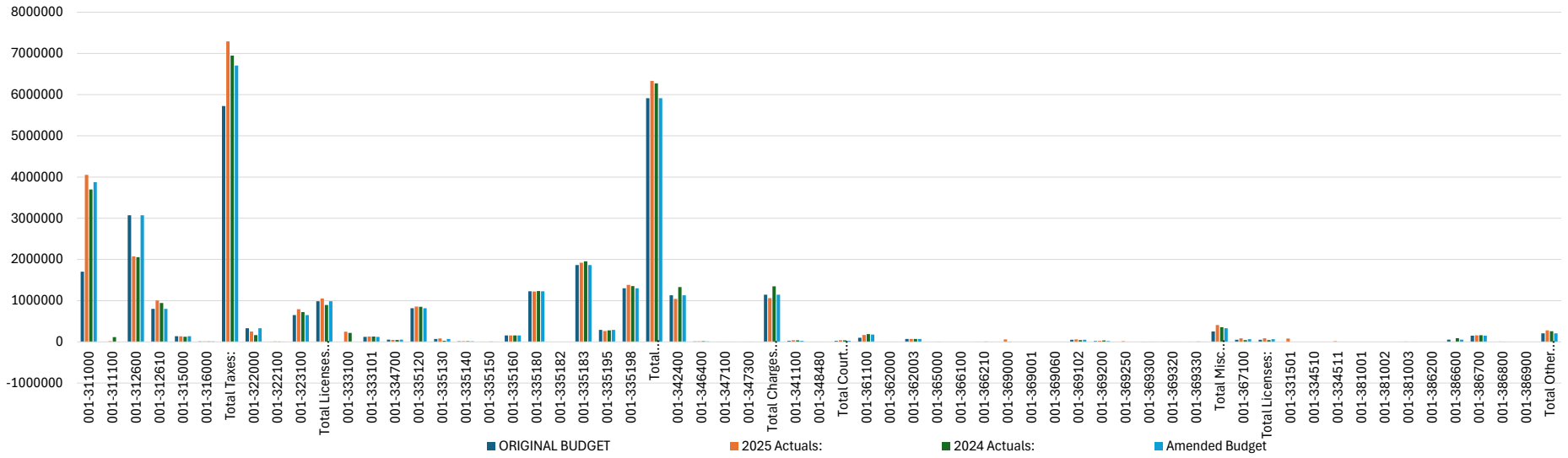

GENERAL FUND (001) BUDGET EXPENSES

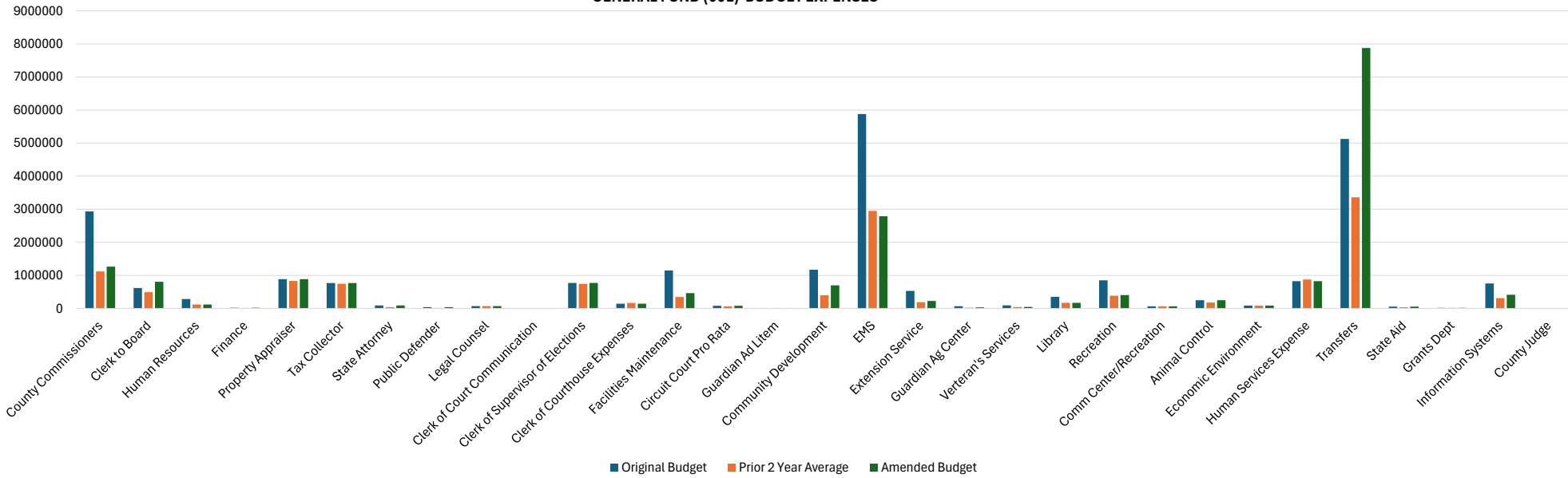

GENERAL FUND (001) CHARTS

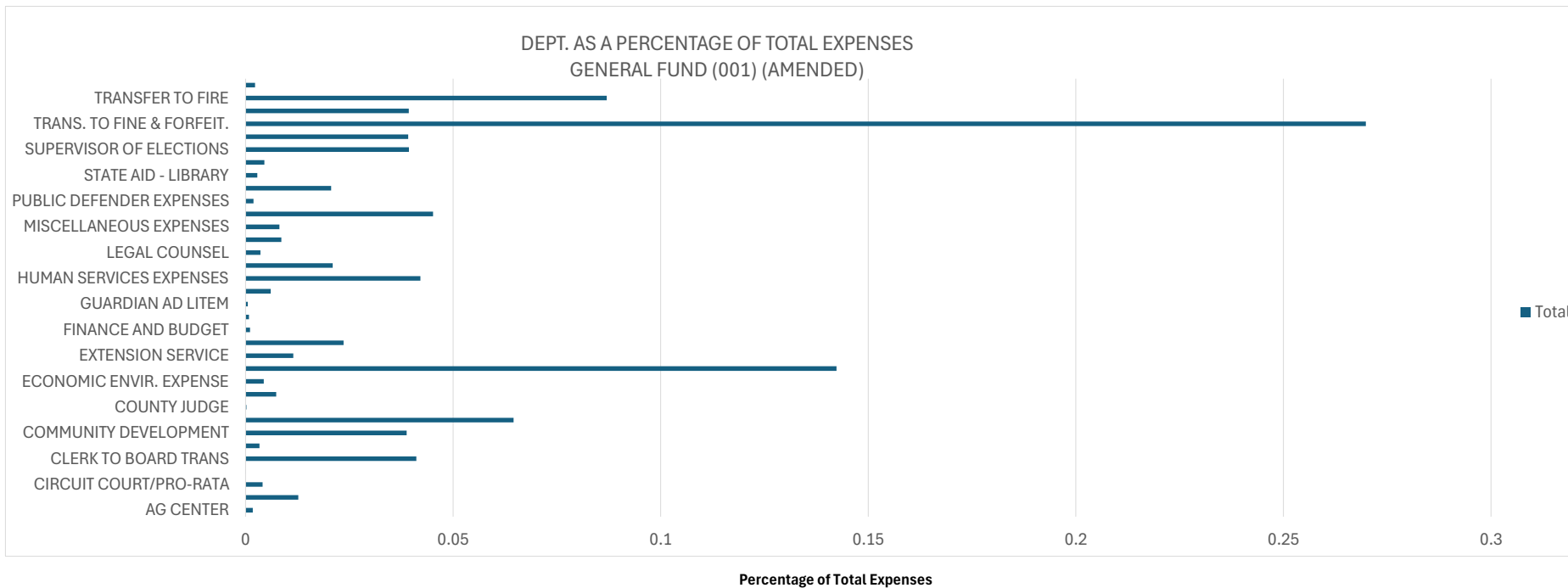
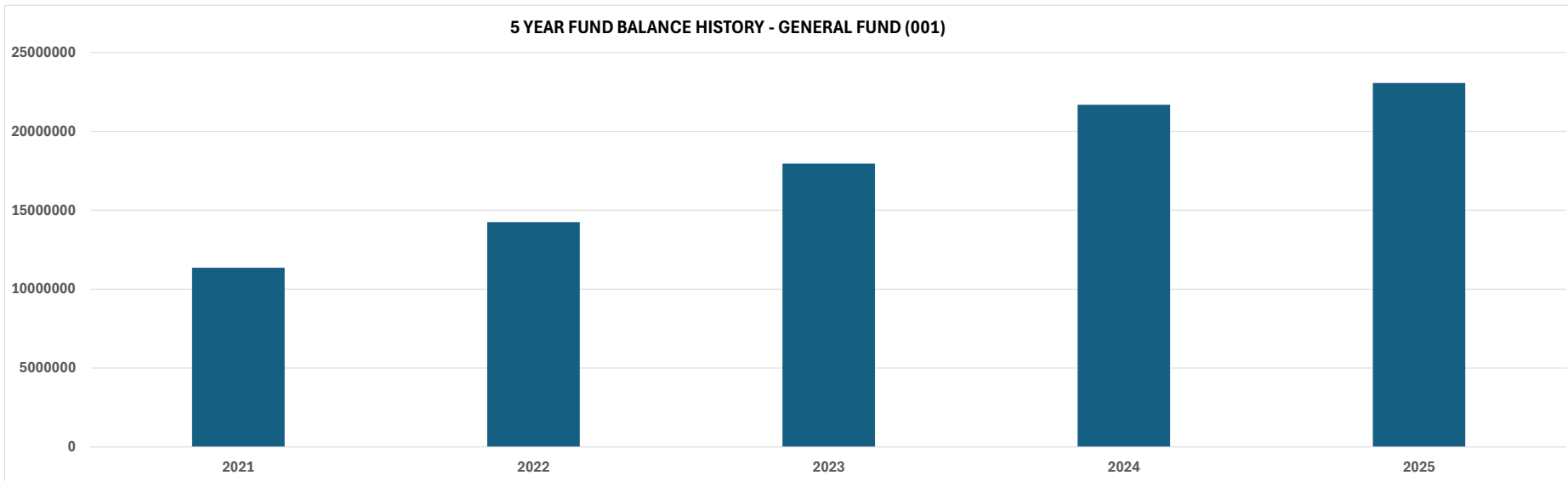

**SUPPLEMENTAL BUDGET AMENDMENT WORKSHEET**

**ROAD & BRIDGE FUND (103)**

**FISCAL YEAR 2025-2026**

AMENDED REVENUES	
CONSTITUTIONAL FUEL TAX	865,117.00
COUNTY GAS TAX	381,164.00
FOREST REVENUE	70,000.00
HWY LIGHT MAINT.	30,000.00
INSURANCE CLAIM REIMB.	
INTEREST	90,000.00
LOCAL OPTION GAS TAX	994,439.00
MISCELLANEOUS REFUNDS	50,000.00
MISCELLANEOUS REVENUES	
MOTOR FUEL USE TAX	1,500.00
OKEFENOKEE REFUGE	4,000.00
ONE CENT GAS TAX	206,645.00
SECOND LOCAL OPTION GAS TAX	869,513.00
TOWN OF GLEN PAYMENT	-
TRANSFER FROM GEN. REV.	160,000.00
<b>Grand Total</b>	<b>3,722,378.00</b>

AMENDED EXPENSES	
ROAD & BRIDGE EXPENSES ADVERTISING	750.00
ROAD & BRIDGE EXPENSES BUILDING MAINTENANCE	-
ROAD & BRIDGE EXPENSES BUILDINGS	-
ROAD & BRIDGE EXPENSES COMMUNICATIONS	4,000.00
ROAD & BRIDGE EXPENSES CSX REPAIRS/MAINTENANCE	33,000.00
ROAD & BRIDGE EXPENSES ELECTRIC	22,950.00
ROAD & BRIDGE EXPENSES EQUIPMENT	420,574.00
ROAD & BRIDGE EXPENSES EQUIPMENT REPAIRS & MAINT	3,500.00
ROAD & BRIDGE EXPENSES FEMA/TROP STORM DEBBY	-
ROAD & BRIDGE EXPENSES FICA TAXES	97,789.00
ROAD & BRIDGE EXPENSES FUEL	380,000.00
ROAD & BRIDGE EXPENSES FUEL TAXES	5,000.00
ROAD & BRIDGE EXPENSES HEALTH INSURANCE	151,086.00
ROAD & BRIDGE EXPENSES HRA CONTRIBUTION	2,400.00
ROAD & BRIDGE EXPENSES INSURANCE CARRIER	125,000.00
ROAD & BRIDGE EXPENSES INTEREST	-
ROAD & BRIDGE EXPENSES LAND	-
ROAD & BRIDGE EXPENSES LIFE INSURANCE	2,100.00
ROAD & BRIDGE EXPENSES LOAN PMT - EQUIPMENT	345,754.15
ROAD & BRIDGE EXPENSES MIDPOINT PKWY GRNT MATCH	-
ROAD & BRIDGE EXPENSES OFFICE SUPPLIES	2,500.00
ROAD & BRIDGE EXPENSES OPERATING SUPPLIE...	69,000.00
ROAD & BRIDGE EXPENSES OPS SALARIES	-
ROAD & BRIDGE EXPENSES OTHER CURRENT CHARGES	-
ROAD & BRIDGE EXPENSES OVERTIME	97,850.00
ROAD & BRIDGE EXPENSES POSTAGE	50.00
ROAD & BRIDGE EXPENSES PRINCIPAL	-
ROAD & BRIDGE EXPENSES PROFESSIONAL SERVICES	22,000.00
ROAD & BRIDGE EXPENSES RECORDING FEES	-
ROAD & BRIDGE EXPENSES REFUNDS	-
ROAD & BRIDGE EXPENSES REGULAR SALARIES/WAGES	1,160,351.00
ROAD & BRIDGE EXPENSES RENTALS AND LEASES	8,000.00
ROAD & BRIDGE EXPENSES REPAIRS AND MAINTENANCE	7,000.00
ROAD & BRIDGE EXPENSES RETIREMENT - FRS	199,788.00
ROAD & BRIDGE EXPENSES ROAD MATERIALS & SUPPLIES	250,000.00
ROAD & BRIDGE EXPENSES SPECIAL PAY	21,000.00
ROAD & BRIDGE EXPENSES SPECIAL ROAD PROJECTS	600,000.00
ROAD & BRIDGE EXPENSES TRAFFIC LIGHT MAINT	3,000.00
ROAD & BRIDGE EXPENSES TRANS TO ROAD PAVING FUND	-
ROAD & BRIDGE EXPENSES TRAVEL AND PER DIEM	-
ROAD & BRIDGE EXPENSES VEHICLE	223,429.00
ROAD & BRIDGE EXPENSES VEHICLE REPAIRS & MAINT.	150,000.00
ROAD & BRIDGE EXPENSES WORKER'S COMP	200,000.00
<b>Grand Total</b>	<b>4,607,871.15</b>

Amended Budget	
REVENUES	3,722,378.00
LESS 5%	(186,118.90)
BEGINNING FUND BALANCE	1,072,703.61
<b>AVAILABLE FUNDING</b>	<b>4,608,962.71</b>
EXPENSES	4,607,871.15
ENDING FUND BALANCE	1,091.56
<b>TOTAL APPROPRIATIONS</b>	<b>4,608,962.71</b>

Original Budget	
REVENUES	4,912,378.00
LESS 5%	(165,843.90)
CASH FORWARD	68,544
<b>AVAILABLE FUNDING</b>	<b>4,815,078.10</b>
EXPENSES	9,567,109.00
ENDING FUND BALANCE	(4,752,030.90)
<b>TOTAL APPROPRIATIONS</b>	<b>4,815,078.10</b>

**SUPPLEMENTAL BUDGET AMENDMENT WORKSHEET**  
**FINE & FORFEITURE FUND (104)**  
**FISCAL YEAR 2025-2026**

AMENDED REVENUES	
911 RURAL COUNTY GRANT	270,000.00
AD VALOREM TAXES	9,107,962.88
CASH FORWARD	
DELINQUENT TAXES	
E911 COMMUNICATION	178,000.00
FF-DOMESTIC VIOLENCE	175.00
INTER FUND TRANSFER	(3,255.85)
INTEREST	12,000.00
JAG GRANTS	50,000.00
MISCELLANEOUS REFUNDS	9,000.00
MISCELLANEOUS REVENUES	30,000.00
TRANS FR SHERIFF	
TRANSFER FROM GEN. REV.	4,983,123.89
<b>Grand Total</b>	<b>14,637,005.92</b>

AMENDED EXPENSES	
CORRECTIONS INMATE HOUSING	4,328,889.00
CORRECTIONS INMATE MEDICAL	400,000.00
DISPATCH TRANS/CONSTIT. OFFICER	716,188.00
JUDICIAL SECURITY TRANS/CONSTIT. OFFICER	470,960.00
LAW ENFORCEMENT TRANS/CONSTIT. OFFICER	6,496,060.00
MEDICAL EXAMINER M.E. TRANSPORTATION COSTS	15,000.00
MEDICAL EXAMINER MEDICAL EXAMINER	150,000.00
OTHER GRANTS 911 COMMUNICATIONS	178,000.00
OTHER GRANTS 911 RURAL COUNTY GRANT	270,000.00
OTHER GRANTS JAG GRANT	85,656.00
OTHER GRANTS MISCELLANEOUS/GRANTS/ETC.	60,374.00
<b>Grand Total</b>	<b>13,171,127.00</b>

Includes both 2024 and 2025

Amended Budget	
REVENUES	14,637,005.92
LESS 5%	(731,850.30)
BEGINNING FUND BALANCE	(692,155.41)
<b>TOTAL AVAILABLE FUNDING</b>	<b>13,213,000.22</b>
EXPENSES	13,171,127.00
ENDING FUND BALANCE	41,873.22
<b>TOTAL APPROPRIATIONS</b>	<b>13,213,000.22</b>

Original Budget	
REVENUES	14,176,496.15
LESS 5%	(477,643.15)
CASH FORWARD	-
<b>TOTAL AVAILABLE FUNDING</b>	<b>13,698,853.00</b>
EXPENSES	12,993,881.00
ENDING FUND BALANCE	704,972.00
<b>TOTAL APPROPRIATIONS</b>	<b>13,698,853.00</b>

**SUPPLEMENTAL BUDGET AMENDMENT WORKSHEET**

**FIRE DEPT FUND (105)**

**FISCAL YEAR 2025-2026**

AMENDED REVENUES	
ASSESSMENTS	989,326.78
DELINQUENT ASSESSMENTS	2,000.00
TRANSFER FROM GENERAL FUND	1,703,622.29
INTEREST	1,200.00
MISCELLANEOUS REFUNDS	2,000.00
MISCELLANEOUS REVENUES	-
<b>Grand Total</b>	<b>2,698,149.07</b>

AMENDED EXPENSES	
FIRE DEPT. ADVERTISING	250.00
FIRE DEPT. BOOKS,PUBS,MEMBERSHIPS	2,000.00
FIRE DEPT. BUILDING MAINTENANCE	33,000.00
FIRE DEPT. BUILDINGS	50,000.00
FIRE DEPT. COMMUNICATIONS	25,000.00
FIRE DEPT. ELECTRIC	15,000.00
FIRE DEPT. EMPLOYEE UNIFORMS	7,500.00
FIRE DEPT. EQUIPMENT	23,750.00
FIRE DEPT. EQUIPMENT REPAIRS & MAINT	26,000.00
FIRE DEPT. FICA TAXES	59,925.00
FIRE DEPT. FUEL	25,000.00
FIRE DEPT. HEALTH INSURANCE	24,812.00
FIRE DEPT. HRA CONTRIBUTION	480.00
FIRE DEPT. IMPROVEMENTS	-
FIRE DEPT. INSURANCE CARRIER	12,500.00
FIRE DEPT. LAND	-
FIRE DEPT. LIFE INSURANCE	750.00
FIRE DEPT. OFFICE FURNITURE	25,000.00
FIRE DEPT. OFFICE SUPPLIES	500.00
FIRE DEPT. OPERATING SUPPLIES	18,000.00
FIRE DEPT. OPS SALARIES	50,000.00
FIRE DEPT. OTHER CONTRACTUAL	-
FIRE DEPT. OTHER CURRENT CHARGES	-
FIRE DEPT. OVERTIME	225,299.00
FIRE DEPT. POSTAGE	200.00
FIRE DEPT. PROFESSIONAL PHYSICALS	4,000.00
FIRE DEPT. PROFESSIONAL SERVICES	65,000.00
FIRE DEPT. REGULAR SALARIES/WAGES	558,031.00
FIRE DEPT. REPAIRS AND MAINTENANCE	-
FIRE DEPT. RETIREMENT - FRS	256,854.00
FIRE DEPT. SOFTWARE LICENSE	4,767.00
FIRE DEPT. TRAINING	14,000.00
FIRE DEPT. TRANSFER OUT	-
FIRE DEPT. TRAVEL AND PER DIEM	2,500.00
FIRE DEPT. UTILITIES/GAS	3,000.00
FIRE DEPT. VEHICLE	118,116.00
FIRE DEPT. VEHICLE REPAIRS & MAINT.	66,000.00
FIRE DEPT. WATER	2,500.00
<b>Grand Total</b>	<b>1,719,734.00</b>

Amended Budget	
REVENUES	2,698,149.07
LESS 5%	(134,907.45)
BEGINNING FUND BALANCE	(837,634.61)
<b>TOTAL AVAILABLE FUNDING</b>	<b>1,725,607.00</b>
EXPENSES	1,719,734.00
ENDING FUND BALANCE	5,873.00
<b>TOTAL APPROPRIATIONS</b>	<b>1,725,607.00</b>

Original Budget	
REVENUES	3,179,675.34
LESS 5%	(49,566.34)
CASH FORWARD	-
<b>TOTAL AVAILABLE FUNDING</b>	<b>3,130,109.00</b>
EXPENSES	3,881,017.00
ENDING FUND BALANCE	(750,908.00)
<b>TOTAL APPROPRIATIONS</b>	<b>3,130,109.00</b>

**SUPPLEMENTAL BUDGET AMENDMENT WORKSHEET**

**EMS GRANT FUND (108)**

**FISCAL YEAR 2025-2026**

AMENDED REVENUES	
EMS GRANT DOH SOW 22-515	-
INTEREST	
LIFEPAK 35	130,000.00
AED Project	31,677.24
<b>Grand Total</b>	<b>161,677.24</b>

AMENDED EXPENSES		
EMS/FIRE GRANT EXPENSES	\$ 161,677.24	
GRANT EXPENSES		
TRANSFER OUT	629,051.12	ARPA Refund
<b>Grand Total</b>	<b>790,728.36</b>	

Amended Budget	
REVENUES	161,677.24
LESS 5%	(8,083.86)
BEGINNING FUND BALANCE	721,057.43
<b>TOTAL AVAILABLE FUNDING</b>	<b>874,650.81</b>
EXPENSES	790,728.36
ENDING FUND BALANCE	83,922.45
<b>TOTAL APPROPRIATIONS</b>	<b>874,650.81</b>

Original Budget	
REVENUES	75,000.00
LESS 5%	
CASH FORWARD	
<b>TOTAL AVAILABLE FUNDING</b>	<b>75,000.00</b>
EXPENSES	75,000.00
ENDING FUND BALANCE	-
<b>TOTAL APPROPRIATIONS</b>	<b>75,000.00</b>

**SUPPLEMENTAL BUDGET AMENDMENT WORKSHEET**

**HEALTH REIMBURSEMENT FUND (110)**

**FISCAL YEAR 2025-2026**

AMENDED REVENUES	
HRA CONTRIBUTIONS	28,000.00
INTEREST	3,000.00
MISCELLANEOUS REVENUES	
WELLNESS FUNDS REVENUE	
<b>Grand Total</b>	<b>31,000.00</b>

AMENDED EXPENSES	
HEALTH REIMBURSEMENT DEPT REFUNDS	\$ 215,000.00
<b>Grand Total</b>	<b>215,000.00</b>

Amended Budget	
REVENUES	31,000.00
LESS 5%	(1,550.00)
BEGINNING FUND BALANCE	210,301.45
<b>TOTAL AVAILABLE FUNDING</b>	<b>239,751.45</b>
EXPENSES	215,000.00
ENDING FUND BALANCE	24,751.45
<b>TOTAL APPROPRIATIONS</b>	<b>239,751.45</b>

Original Budget	
REVENUES	31,000.00
LESS 5%	
CASH FORWARD	169,000
<b>TOTAL AVAILABLE FUNDING</b>	<b>200,000.00</b>
EXPENSES	215,000.00
ENDING FUND BALANCE	(15,000.00)
<b>TOTAL APPROPRIATIONS</b>	<b>200,000.00</b>

**SUPPLEMENTAL BUDGET AMENDMENT WORKSHEET**

**TOURIST DEVELOPMENT FUND (111)**

**FISCAL YEAR 2025-2026**

AMENDED REVENUES	
INTEREST	9,000.00
TOURIST TAX	700,000.00
<b>Grand Total</b>	<b>709,000.00</b>

AMENDED EXPENSES	
TOURIST DEVELOPMENT CAPITAL OUTLAY	\$ 11,000.00
TOURIST DEVELOPMENT PROMOTIONAL ACTIVIT...	700,000.00
TOURIST DEVELOPMENT TRANS/CONSTIT. OFFI...	10,000.00
<b>Grand Total</b>	<b>721,000.00</b>

Amended Budget	
REVENUES	709,000.00
LESS 5%	(35,450.00)
BEGINNING FUND BALANCE	1,450,536.22
<b>TOTAL AVAILABLE FUNDING</b>	<b>2,124,086.22</b>
EXPENSES	721,000.00
ENDING FUND BALANCE	1,403,086.22
<b>TOTAL APPROPRIATIONS</b>	<b>2,124,086.22</b>

Original Budget	
REVENUES	709,000.00
LESS 5%	(35,000.00)
CASH FORWARD	26,000
<b>TOTAL AVAILABLE FUNDING</b>	<b>700,000.00</b>
EXPENSES	721,000.00
ENDING FUND BALANCE	(21,000.00)
<b>TOTAL APPROPRIATIONS</b>	<b>700,000.00</b>

**SUPPLEMENTAL BUDGET AMENDMENT WORKSHEET**

**LAW LIBRARY FUND (112)  
LEGAL AID TRUST FUND (113)  
JUVENILE TRUST FUND (114)**

**FISCAL YEAR 2025-2026**

<b>112 AMENDED REVENUES</b>	
ADD'L COURT COST/ST 939.185	9,500.00

<b>112 AMENDED EXPENSES</b>	
LAW LIBRARY TRUST FUND TRANSFER OUT	\$ 9,500.00

<b>112 Amended Budget</b>	
REVENUES	9,500.00
LESS 5%	(475.00)
BEGINNING FUND BALANCE	6,454.85
<b>TOTAL BUDGET</b>	<b>15,479.85</b>
EXPENSES	9,500.00
ENDING FUND BALANCE	5,979.85
<b>TOTAL BUDGET</b>	<b>15,479.85</b>

<b>112 Original Budget</b>	
REVENUES	9,500.00
LESS 5%	
CASH FORWARD	
<b>TOTAL BUDGET</b>	<b>9,500.00</b>
EXPENSES	9,500.00
ENDING FUND BALANCE	-
<b>TOTAL BUDGET</b>	<b>9,500.00</b>

<b>113 AMENDED REVENUES</b>	
ADD'L COURT COST/ST 939.185	9,500.00

<b>113 AMENDED EXPENSES</b>	
LEGAL AID TRUST FUND TRANSFER TO AGENCY	\$ 9,500.00

<b>113 Amended Budget</b>	
REVENUES	9,500.00
LESS 5%	(475.00)
BEGINNING FUND BALANCE	-
<b>TOTAL BUDGET</b>	<b>9,025.00</b>
EXPENSES	9,500.00
ENDING FUND BALANCE	(475.00)
<b>TOTAL BUDGET</b>	<b>9,025.00</b>

<b>113 Original Budget</b>	
REVENUES	9,500.00
LESS 5%	-
CASH FORWARD	-
<b>TOTAL BUDGET</b>	<b>9,500.00</b>
EXPENSES	9,500.00
ENDING FUND BALANCE	-
<b>TOTAL BUDGET</b>	<b>9,500.00</b>

<b>114 AMENDED REVENUES</b>	
ADD'L COURT COST/ST 939.185	9,500.00

<b>114 AMENDED EXPENSES</b>	
JUVENILE TRUST FUND TRANSFER OUT	\$ 9,500.00

<b>114 Amended Budget</b>	
REVENUES	9,500.00
LESS 5%	(475.00)
BEGINNING FUND BALANCE	6,461.87
<b>TOTAL BUDGET</b>	<b>15,486.87</b>
EXPENSES	9,500.00
ENDING FUND BALANCE	5,986.87
<b>TOTAL BUDGET</b>	<b>15,486.87</b>

<b>114 Original Budget</b>	
REVENUES	9,500.00
LESS 5%	-
CASH FORWARD	-
<b>TOTAL BUDGET</b>	<b>9,500.00</b>
EXPENSES	9,500.00
ENDING FUND BALANCE	-
<b>TOTAL BUDGET</b>	<b>9,500.00</b>

**SUPPLEMENTAL BUDGET AMENDMENT WORKSHEET**

**CRIME PREVENTION FUND (115)**

**FISCAL YEAR 2025-2026**

AMENDED REVENUES	
COUNTY CRIM COURT COSTS	12,550.00

AMENDED EXPENSES	
CRIME PREVENTION T.F. TRANS/CONSTIT. OFF...	\$ 12,550.00

Amended Budget	
REVENUES	12,550.00
LESS 5%	(627.50)
BEGINNING FUND BALANCE	90,123.17
<b>TOTAL AVAILABLE FUNDING</b>	<b>102,045.67</b>
EXPENSES	12,550.00
ENDING FUND BALANCE	89,495.67
<b>TOTAL APPROPRIATIONS</b>	<b>102,045.67</b>

Original Budget	
REVENUES	12,550.00
LESS 5%	
CASH FORWARD	
<b>TOTAL AVAILABLE FUNDING</b>	<b>12,550.00</b>
EXPENSES	12,550.00
ENDING FUND BALANCE	-
<b>TOTAL APPROPRIATIONS</b>	<b>12,550.00</b>

**SUPPLEMENTAL BUDGET AMENDMENT WORKSHEET**

**SOLID WASTE FUND (116)**

**FISCAL YEAR 2025-2026**

AMENDED REVENUES	
ASSESSMENTS	405,405.00
DELINQUENT ASSESSMENTS	
INSURANCE CLAIM REIMB.	
INTEREST	100.00
MISCELLANEOUS REFUNDS	10,000.00
MISCELLANEOUS REVENUES	
NEW RIVER REIMBURSEMENT	329,812.02
SMALL COUNTY GRANT	93,000.00
TRANS FROM GEN REV	800,773.73
<b>Grand Total</b>	<b>1,639,090.75</b>

AMENDED EXPENSES	
SOLID WASTE ADVERTISING	-
SOLID WASTE BUILDING	5,000.00
SOLID WASTE COMMUNICATIONS	5,000.00
SOLID WASTE ELECTRIC	7,000.00
SOLID WASTE EQUIPMENT	23,096.00
SOLID WASTE FICA TAXES	14,137.00
SOLID WASTE FUEL	62,000.00
SOLID WASTE HEALTH INSURANCE	12,145.00
SOLID WASTE HRA CONTRIBUTION	240.00
SOLID WASTE IMPROVEMENTS	-
SOLID WASTE LIFE INSURANCE	225.00
SOLID WASTE NEW RIVER TIPPING FEE	300,000.00
SOLID WASTE OFFICE SUPPLIES	-
SOLID WASTE OPERATING SUPPLIES	12,000.00
SOLID WASTE OTHER CURRENT CHARGES	-
SOLID WASTE OVERTIME	15,450.00
SOLID WASTE PROFESSIONAL SERVICES	-
SOLID WASTE RECYCLING SITE ATTENDANTS	300,000.00
SOLID WASTE REGULAR SALARIES/WAGES	169,340.00
SOLID WASTE RENTALS AND LEASES	7,000.00
SOLID WASTE REPAIRS AND MAINTENANCE	8,000.00
SOLID WASTE RETIREMENT - FRS	25,187.00
SOLID WASTE SPECIAL PAY	5,250.00
SOLID WASTE TRANSFER OUT	-
SOLID WASTE VEHICLE	230,999.00
SOLID WASTE VEHICLE REPAIRS & MAINT.	55,000.00
<b>Grand Total</b>	<b>1,257,069.00</b>

Amended Budget	
REVENUES	1,639,090.75
LESS 5%	(81,954.54)
BEGINNING FUND BALANCE	(300,040.50)
<b>TOTAL AVAILABLE FUNDING</b>	<b>1,257,095.72</b>
EXPENSES	1,257,069.00
ENDING FUND BALANCE	26.72
<b>TOTAL APPROPRIATIONS</b>	<b>1,257,095.72</b>

Original Budget	
REVENUES	1,223,900.25
LESS 5%	(20,270.25)
CASH FORWARD	
<b>TOTAL AVAILABLE FUNDING</b>	<b>1,203,630.00</b>
EXPENSES	2,336,051.00
ENDING FUND BALANCE	(1,132,421.00)
<b>TOTAL APPROPRIATIONS</b>	<b>1,203,630.00</b>

**SUPPLEMENTAL BUDGET AMENDMENT WORKSHEET**

**ALCOHOL/DRUG ABUSE FUND (117)**

**FISCAL YEAR 2025-2026**

AMENDED REVENUES	
ADDITIONAL COURT COSTS	750.00

AMENDED EXPENSES	
ALCOHOL/DRUG ABUSE EXPENS TRANSFER TO AGENCY	750.00

Amended Budget	
REVENUES	750.00
LESS 5%	(37.50)
BEGINNING FUND BALANCE	39,317.03
<b>TOTAL AVAILABLE FUNDING</b>	<b>40,029.53</b>
EXPENSES	750.00
ENDING FUND BALANCE	39,279.53
<b>TOTAL APPROPRIATIONS</b>	<b>40,029.53</b>

Original Budget	
REVENUES	750.00
LESS 5%	-
CASH FORWARD	
<b>TOTAL AVAILABLE FUNDING</b>	<b>750.00</b>
EXPENSES	750.00
ENDING FUND BALANCE	-
<b>TOTAL APPROPRIATIONS</b>	<b>750.00</b>

**SUPPLEMENTAL BUDGET AMENDMENT WORKSHEET**

**COURT FACILITIES FUND (119)**

**FISCAL YEAR 2025-2026**

AMENDED REVENUES	
CIR CRT IMP F.S. 938.18	10.00
CR TRAFF CR IMP ORD#04-36	100.00
INTEREST	300.00
INTERFUND TRANSFER F GENERAL	-
TRAFFIC COURT IMPROVEMENT	44,458.98
<b>Grand Total</b>	<b>44,868.98</b>

AMENDED EXPENSES	
COURT FACILITY EXPENSES BUILDING MAINTENANCE	30,000.00
COURT FACILITY EXPENSES COMMUNICATIONS	-
COURT FACILITY EXPENSES COURT SECURITY MAINTENANC	5,000.00
COURT FACILITY EXPENSES CT.TECHNOLOGY EXPNS.	-
COURT FACILITY EXPENSES EQUIPMENT	-
COURT FACILITY EXPENSES GIVING BACK TO BAKER EXPN	7,500.00
COURT FACILITY EXPENSES IMPROVEMENTS	-
COURT FACILITY EXPENSES OPERATING SUPPLIES	4,500.00
COURT FACILITY EXPENSES OTHER CONTRACTUAL	-
COURT FACILITY EXPENSES PROFESSIONAL SERVICES	-
COURT FACILITY EXPENSES REPAIRS AND MAINTENANCE	60,000.00
<b>Grand Total</b>	<b>107,000.00</b>

Amended Budget	
REVENUES	44,868.98
LESS 5%	(2,243.45)
BEGINNING FUND BALANCE	78,979.32
<b>TOTAL AVAILABLE FUNDING</b>	<b>121,604.85</b>
EXPENSES	107,000.00
ENDING FUND BALANCE	14,604.85
<b>TOTAL APPROPRIATIONS</b>	<b>121,604.85</b>

Original Budget	
REVENUES	129,410.00
LESS 5%	
CASH FORWARD	59,090
<b>TOTAL AVAILABLE FUNDING</b>	<b>188,500.00</b>
EXPENSES	187,000.00
ENDING FUND BALANCE	1,500.00
<b>TOTAL APPROPRIATIONS</b>	<b>188,500.00</b>

**SUPPLEMENTAL BUDGET AMENDMENT WORKSHEET**

**DRIVER'S ED TRUST FUND (120)**

**FISCAL YEAR 2025-2026**

AMENDED REVENUES	
ADDITIONAL COURT COSTS	7,500.00

AMENDED EXPENSES	
DRIVER'S ED TRUST FUND TRANSFER TO AGENCY	\$ 7,500.00

Amended Budget	
REVENUES	7,500.00
LESS 5%	(375.00)
BEGINNING FUND BALANCE	-
<b>TOTAL AVAILABLE FUNDING</b>	<b>7,125.00</b>
EXPENSES	7,500.00
ENDING FUND BALANCE	(375.00)
<b>TOTAL APPROPRIATIONS</b>	<b>7,125.00</b>

Original Budget	
REVENUES	7,500.00
LESS 5%	
CASH FORWARD	-
<b>TOTAL AVAILABLE FUNDING</b>	<b>7,500.00</b>
EXPENSES	7,500.00
ENDING FUND BALANCE	-
<b>TOTAL APPROPRIATIONS</b>	<b>7,500.00</b>

**SUPPLEMENTAL BUDGET AMENDMENT WORKSHEET**

**SPECIAL LAW ENFORCEMENT FUND (121)**

**FISCAL YEAR 2025-2026**

AMENDED REVENUES	
ADDITIONAL COURT COSTS	45,000.00

AMENDED EXPENSES	
EXPENSES-SPECIAL LAW TRANS/CONSTIT. OFFI...	\$ 45,000.00

Amended Budget	
REVENUES	45,000.00
LESS 5%	-
BEGINNING FUND BALANCE	1,239.88
<b>TOTAL BUDGET</b>	<b>46,239.88</b>
EXPENSES	45,000.00
ENDING FUND BALANCE	1,239.88
<b>TOTAL BUDGET</b>	<b>46,239.88</b>

Original Budget	
REVENUES	45,000.00
LESS 5%	-
CASH FORWARD	-
<b>TOTAL AVAILABLE FUNDING</b>	<b>45,000.00</b>
EXPENSES	45,000.00
ENDING FUND BALANCE	-
<b>TOTAL APPROPRIATIONS</b>	<b>45,000.00</b>

**SUPPLEMENTAL BUDGET AMENDMENT WORKSHEET**

**SHIP FUND (122)**

**FISCAL YEAR 2025-2026**

AMENDED REVENUES	
GRANT FUNDS/STATE	350,000.00
INTEREST	800.00
MISCELLANEOUS REFUNDS	5,000.00
<b>CBDG GRANT</b>	<b>750,000.00</b>
<b>Grand Total</b>	<b>1,105,800.00</b>

AMENDED EXPENSES	
SHIP FUNDS/24-25 OTHER CONTRACTUAL	73,726.23
SHIP FUNDS/25-26 OTHER CONTRACTUAL	350,000.00
SHIP OPERATIONS ADVERTISING	700.00
SHIP OPERATIONS ELECTRIC	900.00
SHIP OPERATIONS FICA TAXES	1,273.00
SHIP OPERATIONS FUEL	200.00
SHIP OPERATIONS HEALTH INSURANCE	3,167.00
SHIP OPERATIONS HRA CONTRIBUTION	60.00
SHIP OPERATIONS LIFE INSURANCE	75.00
SHIP OPERATIONS OFFICE SUPPLIES	600.00
SHIP OPERATIONS OPERATING SUPPLIES	400.00
SHIP OPERATIONS POSTAGE	125.00
SHIP OPERATIONS RECORDING FEES	2,100.00
SHIP OPERATIONS REGULAR SALARIES/WAGES	16,640.00
SHIP OPERATIONS RENTALS AND LEASES	200.00
SHIP OPERATIONS RETIREMENT - FRS	2,269.00
SHIP OPERATIONS SOFTWARE LICENSE	4,860.00
<b>CBDG GRANT</b>	<b>750,000.00</b>
<b>Grand Total</b>	<b>1,207,295.23</b>

Amended Budget	
REVENUES	1,105,800.00
LESS 5%	-
BEGINNING FUND BALANCE	435,385
<b>TOTAL BUDGET</b>	<b>1,541,184.51</b>
EXPENSES	1,207,295.23
ENDING FUND BALANCE	333,889.28
<b>TOTAL BUDGET</b>	<b>1,541,184.51</b>

Original Budget	
REVENUES	355,800.00
LESS 5%	
CASH FORWARD	161,737
<b>TOTAL AVAILABLE FUNDING</b>	<b>517,537.00</b>
EXPENSES	828,709.00
ENDING FUND BALANCE	(311,172.00)
<b>TOTAL APPROPRIATIONS</b>	<b>517,537.00</b>

**SUPPLEMENTAL BUDGET AMENDMENT WORKSHEET**

**SHOALS PARK (123)**

**FISCAL YEAR 2025-2026**

AMENDED REVENUES	
MISCELLANEOUS REFUNDS	
MISCELLANEOUS REVENUES	
SALE OF TIMBER	200,000.00
SHOALS PARK CHARGES	15,000.00
ST. MARY'S SHOALS GRANT	
<b>Grand Total</b>	<b>215,000.00</b>

AMENDED EXPENSES	
SHOALS PARK 2016 ADVERTISING	\$ -
SHOALS PARK 2016 BUILDINGS	50,000.00
SHOALS PARK 2016 COMMISSION & FEES	1,250.00
SHOALS PARK 2016 COMMUNICATIONS	-
SHOALS PARK 2016 CONTINGENCY RESERVES	14,000.00
SHOALS PARK 2016 EQUIPMENT	-
SHOALS PARK 2016 FEE FOR SERVICE	18,000.00
SHOALS PARK 2016 FUEL	3,000.00
SHOALS PARK 2016 IMPROVEMENTS	-
SHOALS PARK 2016 OPERATING SUPPLIES	5,000.00
SHOALS PARK 2016 OTHER CONTRACTUAL	60,000.00
SHOALS PARK 2016 PROFESSIONAL SERVICES	83,900.00
SHOALS PARK 2016 RENTALS AND LEASES	-
SHOALS PARK 2016 REPAIRS AND MAINTENANCE	20,000.00
SHOALS PARK 2016 ST. MARY'S SHOALS GRANT	-
SHOALS PARK 2016 UTILITY SERVICES	6,000.00
SHOALS PARK 2016 VEHICLE REPAIRS & MAINT.	7,000.00
SHOALS PARK MACHINERY	28,420.00
SHOALS PARK VEHICLE	-
<b>Grand Total</b>	<b>296,570.00</b>

Amended Budget	
REVENUES	215,000.00
LESS 5%	(10,750.00)
BEGINNING FUND BALANCE	123,471.78
<b>TOTAL AVAILABLE FUNDING</b>	<b>327,721.78</b>
EXPENSES	296,570.00
ENDING FUND BALANCE	31,151.78
<b>TOTAL APPROPRIATIONS</b>	<b>327,721.78</b>

Original Budget	
REVENUES	215,075.00
LESS 5%	
CASH FORWARD	91,495
<b>TOTAL AVAILABLE FUNDING</b>	<b>306,570.00</b>
EXPENSES	296,570.00
ENDING FUND BALANCE	10,000.00
<b>TOTAL APPROPRIATIONS</b>	<b>306,570.00</b>

**SUPPLEMENTAL BUDGET AMENDMENT WORKSHEET  
BOATING IMPROVEMENT FUND (133)**

**FISCAL YEAR 2025-2026**

<b>AMENDED REVENUES</b>	
BOATING IMPROVEMENT FUNDS	
FBIP-ST.MARY BOAT GRNT	394,130.00
INTEREST	105.00
TRANSFER FROM GEN. FUND	228,587.22
<b>Grand Total</b>	<b>622,822.22</b>

<b>AMENDED EXPENSES</b>	
BOATING IMPR. FUND TRANSFER TO GENERAL	-
BOATING IMPROVEMENT FUND BOATING IMPROVEMENT FUND	8,105.00
BOATING IMPROVEMENT FUND FBIP-ST.MARY COVE BOAT RA	394,130.00
BOATING IMPROVEMENT FUND RESERVE-CAP IMPROVEMENT	-
<b>Grand Total</b>	<b>402,235.00</b>

<b>Amended Budget</b>	
REVENUES	622,822.22
LESS 5%	
BEGINNING FUND BALANCE	(220,586.32)
<b>TOTAL BUDGET</b>	<b>402,235.90</b>
EXPENSES	402,235.00
ENDING FUND BALANCE	0.90
<b>TOTAL BUDGET</b>	<b>402,235.90</b>

<b>Original Budget</b>	
REVENUES	8,105.00
LESS 5%	
CASH FORWARD	200,000
<b>TOTAL AVAILABLE FUNDING</b>	<b>208,105.00</b>
EXPENSES	546,105.00
ENDING FUND BALANCE	(338,000.00)
<b>TOTAL APPROPRIATIONS</b>	<b>208,105.00</b>

**SUPPLEMENTAL BUDGET AMENDMENT WORKSHEET**

**COURT INNOVATIONS TRUST FUND (139)**

**FISCAL YEAR 2025-2026**

AMENDED REVENUES	
ADDT'L COURT COST/ST 939.	5,000.00
INTEREST	100.00
TRANSFER IN	14,000.00
<b>Grand Total</b>	<b>19,100.00</b>

AMENDED EXPENSES	
COURT INNOVATIONS TRUST COMMUNICATIONS	\$ 1,000.00
COURT INNOVATIONS TRUST IMPROVEMENTS	50,000.00
COURT INNOVATIONS TRUST OTHER PROF. SERVICES	35,000.00
COURT INNOVATIONS TRUST PROF SERV/DRUG COURT	-
COURT INNOVATIONS TRUST REPAIRS AND MAINTENANCE	-
<b>Grand Total</b>	<b>86,000.00</b>

Amended Budget	
REVENUES	19,100.00
LESS 5%	(955.00)
BEGINNING FUND BALANCE	250,706.44
<b>TOTAL AVAILABLE FUNDING</b>	<b>268,851.44</b>
EXPENSES	86,000.00
ENDING FUND BALANCE	182,851.44
<b>TOTAL APPROPRIATIONS</b>	<b>268,851.44</b>

Original Budget	
REVENUES	19,100.00
LESS 5%	
CASH FORWARD	226,900
<b>TOTAL AVAILABLE FUNDING</b>	<b>246,000.00</b>
EXPENSES	326,000.00
ENDING FUND BALANCE	(80,000.00)
<b>TOTAL APPROPRIATIONS</b>	<b>246,000.00</b>

**SUPPLEMENTAL BUDGET AMENDMENT WORKSHEET**

**12.50 SC FUND (166)**

**FISCAL YEAR 2025-2026**

AMENDED REVENUES	
911 - 12.50 SURCHARGE	10,000.00
INTEREST	2.00
TRANSFER IN	56,498.00
<b>Grand Total</b>	<b>66,500.00</b>

AMENDED EXPENSES	
12.50 SC REPAIRS AND MAINTENANCE	\$ 48,000.00
<b>Grand Total</b>	<b>48,000.00</b>

Amended Budget	
REVENUES	66,500.00
LESS 5%	(3,325.00)
BEGINNING FUND BALANCE	(14,714.48)
<b>TOTAL AVAILABLE FUNDING</b>	<b>48,460.52</b>
EXPENSES	48,000.00
ENDING FUND BALANCE	460.52
<b>TOTAL APPROPRIATIONS</b>	<b>48,460.52</b>

Original Budget	
REVENUES	66,500.00
LESS 5%	
CASH FORWARD	-
<b>TOTAL AVAILABLE FUNDING</b>	<b>66,500.00</b>
EXPENSES	48,000.00
ENDING FUND BALANCE	18,500.00
<b>TOTAL APPROPRIATIONS</b>	<b>66,500.00</b>

**SUPPLEMENTAL BUDGET AMENDMENT WORKSHEET**

**IMPACT FEE TRUST FUND (180)**

**FISCAL YEAR 2025-2026**

AMENDED REVENUES	
ADMINISTRATIVE FEES	3,300.00
INTEREST	
<b>Grand Total</b>	<b>3,300.00</b>

AMENDED EXPENSES		
IMPACT FEE TRUST FUND EXP TRANSFER TO GEN. REV.	\$	3,300.00
<b>Grand Total</b>		<b>3,300.00</b>

Amended Budget	
REVENUES	3,300.00
LESS 5%	(165.00)
BEGINNING FUND BALANCE	-
<b>TOTAL AVAILABLE FUNDING</b>	<b>3,135.00</b>
EXPENSES	3,300.00
ENDING FUND BALANCE	(165.00)
<b>TOTAL APPROPRIATIONS</b>	<b>3,135.00</b>

Original Budget	
REVENUES	3,300.00
LESS 5%	
CASH FORWARD	-
<b>TOTAL AVAILABLE FUNDING</b>	<b>3,300.00</b>
EXPENSES	3,300.00
ENDING FUND BALANCE	-
<b>TOTAL APPROPRIATIONS</b>	<b>3,300.00</b>

**SUPPLEMENTAL BUDGET AMENDMENT WORKSHEET**

**PARAMEDICINE GRANT FUND (197)**

**FISCAL YEAR 2025-2026**

AMENDED REVENUES	
LSF Grant	41,975.00
Opioid Settlements	55,444.00
LSF Grant- CORE	8,750.00
<b>Grand Total</b>	<b>106,169.00</b>

AMENDED EXPENSES	
COUNTY GRANT WITH LABOR REGULAR SALAR	\$ 78,400.00
COUNTY GRANT WITH LABOR EQUIPMENT	13,600.00
COUNTY GRANT WITH LABOR OPERATING SUP	7,250.00
COUNTY GRANT WITH LABOR VEHICLE	4,250.00
COUNTY GRANT WITH LABOR TRAINING	7,400.00
<b>Grand Total</b>	<b>110,900.00</b>

Amended Budget	
REVENUES	106,169.00
LESS 5%	(5,308.45)
BEGINNING FUND BALANCE	88,924.85
<b>TOTAL AVAILABLE FUNDING</b>	<b>189,785.40</b>
EXPENSES	110,900.00
ENDING FUND BALANCE	78,885.40
<b>TOTAL APPROPRIATIONS</b>	<b>189,785.40</b>

Original Budget	
REVENUES	327,638.00
LESS 5%	
CASH FORWARD	33,971
<b>TOTAL AVAILABLE FUNDING</b>	<b>361,609.00</b>
EXPENSES	-
ENDING FUND BALANCE	361,609.00
<b>TOTAL APPROPRIATIONS</b>	<b>361,609.00</b>

**SUPPLEMENTAL BUDGET AMENDMENT WORKSHEET**

**LATCF - LOACL ASSISTANCE TRIBAL FUND (201)**

**FISCAL YEAR 2025-2026**

AMENDED REVENUES	
CASH FORWARD LATCF-EQUITY IN PC	510,885.00
<b>Grand Total</b>	<b>510,885.00</b>

AMENDED EXPENSES

Amended Budget	
REVENUES	510,885.00
LESS 5%	(25,544.25)
BEGINNING FUND BALANCE	(0.32)
<b>TOTAL AVAILABLE FUNDING</b>	<b>485,340.43</b>
EXPENSES	-
ENDING FUND BALANCE	485,340.43
<b>TOTAL APPROPRIATIONS</b>	<b>485,340.43</b>

Original Budget	
REVENUES	510,885.00
LESS 5%	
CASH FORWARD	
<b>TOTAL AVAILABLE FUNDING</b>	<b>510,885.00</b>
EXPENSES	501,000.00
ENDING FUND BALANCE	9,885.00
<b>TOTAL APPROPRIATIONS</b>	<b>510,885.00</b>

**SUPPLEMENTAL BUDGET AMENDMENT WORKSHEET  
NATIONAL FOREST/TITLE III - FIREWISE FUND (255)**

**FISCAL YEAR 2025-2026**

AMENDED REVENUES	
INTEREST	1,100.00
TITLE III / NATIONAL FOREST	47,231.98
<b>Grand Total</b>	<b>48,331.98</b>

AMENDED EXPENSES	
NATIONAL FOREST/TITLE III EQUIPMENT	\$ 6,000.00
NATIONAL FOREST/TITLE III FICA TAXES	765.00
NATIONAL FOREST/TITLE III OPERATING SUPPLIES	1,219.00
NATIONAL FOREST/TITLE III REGULAR SALARIES/WAGES	10,000.00
NATIONAL FOREST/TITLE III REPAIRS AND MAINTENANCE	15,000.00
NATIONAL FOREST/TITLE III RETIREMENT - FRS	3,519.00
NATIONAL FOREST/TITLE III TRAINING	24,000.00
NATIONAL FOREST/TITLE III VEHICLE	55,000.00
NATIONAL FOREST/TITLE III VEHICLE REPAIRS & MAINT.	30,000.00
<b>Grand Total</b>	<b>145,503.00</b>

Amended Budget	
REVENUES	48,331.98
LESS 5%	(2,416.60)
BEGINNING FUND BALANCE	117,788.51
<b>TOTAL AVAILABLE FUNDING</b>	<b>163,703.89</b>
EXPENSES	145,503.00
ENDING FUND BALANCE	18,200.89
<b>TOTAL APPROPRIATIONS</b>	<b>163,703.89</b>

Original Budget	
REVENUES	1,100.00
LESS 5%	
CASH FORWARD	144,684
<b>TOTAL AVAILABLE FUNDING</b>	<b>145,784.00</b>
EXPENSES	37,594.00
ENDING FUND BALANCE	108,190.00
<b>TOTAL APPROPRIATIONS</b>	<b>145,784.00</b>

**SUPPLEMENTAL BUDGET AMENDMENT WORKSHEET**

**ROAD PAVING FUND (600)**

**FISCAL YEAR 2025-2026**

<b>AMENDED REVENUES</b>	
CR 229N SCRAP US 90-I10	1,000,000.00
SCOP, CR229N VERDIE DORMAN TO N 3.9M	1,973,976.60
SCOP,CR125N BLAIR-PARK	1,152,491.48
SCOP,WILLIS HODGES-SR121	599,450.13
SCRAP,CR127 BEECH ST - WILLIE GRIFFIS	3,230,000.00
SCRAP-CR127/120-MOCCASIN	741,438.34
Nursery Blvd from transmission power lines to US 90-SCOP	8,893.66
<b>Grand Total</b>	<b>8,706,250.21</b>

<b>AMENDED EXPENSES</b>	
ROAD PAVING FUND CR 229S SCRAP US90-I10	\$ 1,000,000.00
ROAD PAVING FUND SCOP CR127N WILLIE GRIFFIS TO CR125	3,230,000.00
ROAD PAVING FUND SCOP NURSERY BLVD-TRANS TO US90	8,893.66
ROAD PAVING FUND SCOP, CR 229N VERDIE DO...	1,973,976.60
ROAD PAVING FUND SCOP,CR125N BLAIR-PARK	1,152,491.48
ROAD PAVING FUND SCOP,WILLIS HODGES-SR121	599,450.13
ROAD PAVING FUND SCRAP-CR127/120-MOCCASIN	741,438.34
<b>Grand Total</b>	<b>8,706,250.21</b>

<b>Amended Budget</b>	
REVENUES	8,706,250.21
LESS 5%	-
BEGINNING FUND BALANCE	(126,372.38)
<b>TOTAL AVAILABLE FUNDING</b>	<b>8,579,877.83</b>
EXPENSES	8,706,250.21
ENDING FUND BALANCE	(126,372.38)
<b>TOTAL APPROPRIATIONS</b>	<b>8,579,877.83</b>

<b>Original Budget</b>	
REVENUES	5,475,125.00
LESS 5%	-
CASH FORWARD	-
<b>TOTAL AVAILABLE FUNDING</b>	<b>5,475,125.00</b>
EXPENSES	5,475,125.00
ENDING FUND BALANCE	-
<b>TOTAL APPROPRIATIONS</b>	<b>5,475,125.00</b>

**BAKER COUNTY DEPARTMENTAL BU**  
**GENERAL FUND**  
**FISCAL YEAR 2025-2026**

BUDGET CATEGORY	24/25 ACTUALS	CURRENT YEAR BUDGET
REVENUES	16,409,780.14	15,172,217.22
TRANSFERS IN	191,202.79	208,000.00
LESS: 5%	(830,049.15)	(769,010.86)
<b>TOTAL REVENUES</b>	<b>15,770,933.78</b>	<b>14,611,206.36</b>
BEGINNING FUND BALANCE	21,680,847.54	23,059,433.01
<b>TOTAL BUDGET</b>	<b>\$ 37,451,781.32</b>	<b>\$ 37,670,639.37</b>

PERSONAL SERVICES	5,174,024.20	5,164,336.79
OPERATING COSTS	5,757,314.65	6,286,361.00
EQUIPMENT	148,789.61	146,730.00
TRANSFERS OUT	4,142,269.00	7,876,107.14
<b>TOTAL EXPENDITURES</b>	<b>15,222,397.46</b>	<b>19,473,534.93</b>
ENDING FUND BALANCE	22,229,383.86	18,197,104.44
<b>TOTAL BUDGET</b>	<b>\$ 37,451,781.32</b>	<b>\$ 37,670,639.37</b>

**FUND BALANCE SUMMARY**

Current Year Estimates

Fund Bal at 9/30/2024	21,680,847.54
2025 Revenues	16,600,982.93
2025 Expenditures	(15,222,397.46)
Current Year Change in Balance	1,378,585.47

Ending Fund Balance for 2025: 23,059,433.01



# DGET

BUDGET CHANGE	REQUESTED PERCENTAGE CHANGE
1,237,562.92	8.16%
16,797.21	8.08%
61,038.29	-7.94%
1,315,398.42	9.00%
1,378,585.47	6.36%
<b>\$ 2,693,983.89</b>	<b>7.15%</b>

9,687.41	0.19%
529,046.35	8.42%
(2,059.61)	-1.40%
3,733,838.14	47.41%
4,270,512.29	21.93%
(1,576,528.40)	-8.66%
<b>\$ 2,693,983.89</b>	<b>7.15%</b>

## FUND BALANCE AT 9/30

2021	11,351,972.81
2022	14,245,068.62
2023	17,948,644.58
2024	21,680,847.54

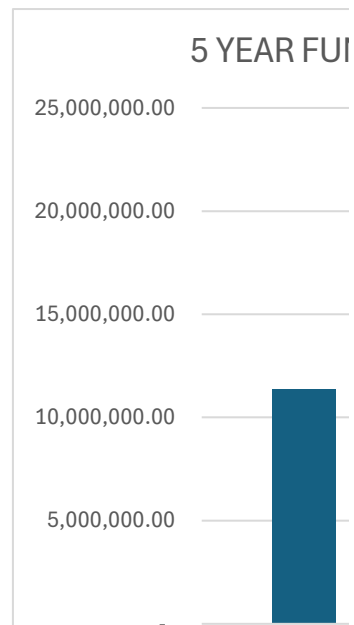

2025

23,059,433.01

2021

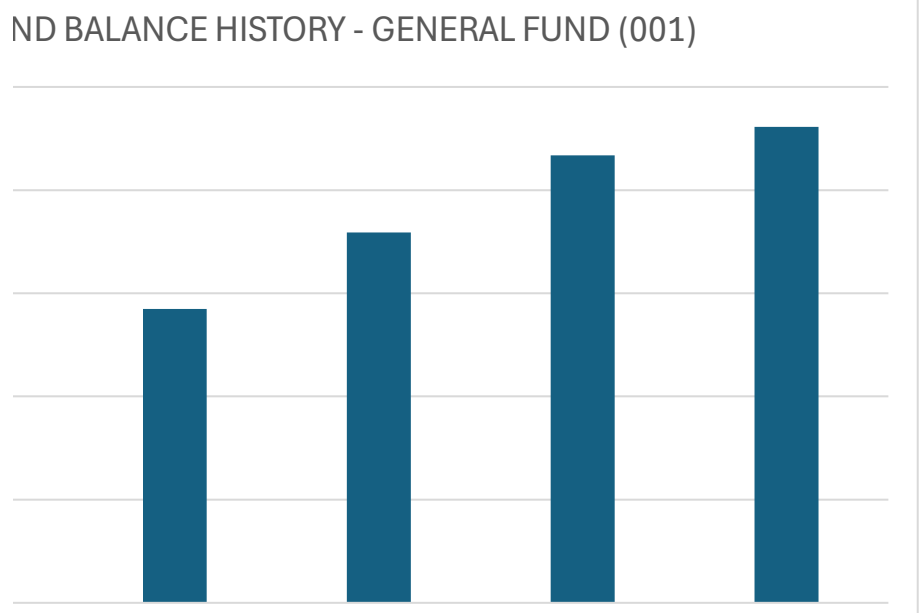

2022

2023

2024

2025

**BAKER COUNTY DEPARTMENTAL BUDGET (APPROVED ON 9/23/2025)**  
**GENERAL FUND**  
**FISCAL YEAR 2025-2026**

BUDGET CATEGORY	24/25	CURRENT YEAR		REQUESTED
	ACTUALS	BUDGET	BUDGET CHANGE	PERCENTAGE CHANGE
REVENUES	16,409,780.14	14,096,742.67	2,313,037.47	16.41%
TRANSFERS IN	191,202.79	208,000.00	16,797.21	8.08%
LESS: 5%	(830,049.15)	(724,904.73)	105,144.41	-14.50%
<b>TOTAL REVENUES</b>	<b>15,770,933.78</b>	<b>13,579,837.94</b>	<b>2,434,979.09</b>	<b>17.93%</b>
CASH FORWARD	21,680,847.54	3,849,785.00	17,831,062.54	463.17%
<b>TOTAL BUDGET</b>	<b>\$ 37,451,781.32</b>	<b>\$ 17,429,622.94</b>	<b>\$ 20,266,041.63</b>	<b>116.27%</b>
PERSONAL SERVICES	5,174,024.20	5,571,323.00	(397,298.80)	-7.13%
OPERATING COSTS	5,757,314.65	9,820,461.00	4,063,146.35	41.37%
EQUIPMENT	148,789.61	513,870.00	365,080.39	71.05%
TRANSFERS OUT	4,142,269.00	8,108,608.67	3,966,339.67	48.92%
<b>TOTAL EXPENDITURES</b>	<b>15,222,397.46</b>	<b>24,014,262.67</b>	<b>7,997,267.61</b>	<b>33.30%</b>
ENDING FUND BALANCE	22,229,383.86	(6,584,639.73)	12,268,774.02	-186.32%
<b>TOTAL BUDGET</b>	<b>\$ 37,451,781.32</b>	<b>\$ 17,429,622.94</b>	<b>\$ 20,266,041.63</b>	<b>116.27%</b>

Board approved on 9/23/2025

**BAKER COUNTY BOARD OF COUNTY COMMISSIONERS**

**BUDGET PRESENTATION 9/23/2025**

FUND	DESCRIPTION	INCOME	EXPENSE	DIFFERENCES
001	<b>GENERAL FUND</b>	<b>17,429,623</b>	<b>17,429,623</b>	<b>0</b>
103	PUBLIC WORKS	4,815,078	4,815,078	0
104	<b>FINE &amp; FORFEITURE FUND</b>	<b>13,698,853</b>	<b>13,698,853</b>	<b>0</b>
105	<b>FIRE DEPARTMENT FUND</b>	<b>3,130,109</b>	<b>3,130,109</b>	<b>0</b>
108	EMS GRANT FUND	75,000	75,000	0
110	HEALTH REIMBURSEMENT FUND	200,000	200,000	0
111	TDC- TOURIST DEV. COMM. FUND	700,000	700,000	0
112	LAW LIBRARY TRUST FUND	9,500	9,500	0
113	LEGAL AID TRUST FUND	9,500	9,500	0
114	JUVENILE TRUST FUND	9,500	9,500	0
115	CRIME PREVENTION T.F.	12,550	12,550	0
116	<b>SOLID WASTE</b>	<b>1,203,630</b>	<b>1,203,630</b>	<b>0</b>
117	ALCOHOL/DRUG ABUSE TRUST	750	750	0
119	COURT FACILITY FUND	188,500	188,500	0
120	DRIVERS ED TRUST FUND	7,500	7,500	0
121	SPECIAL LAW ENFORCEMENT	45,000	45,000	0
122	SHIP FUND	517,537	517,537	0
123	SHOALS PARK	306,570	306,570	0
133	BOATING IMPROVEMENT FUND	208,105	208,105	0
139	COURT INNOVATIONS TRUST	246,000	246,000	0
166	12.50 SC FUND	66,500	66,500	0
180	IMPACT FEE TRUST FUND	3,300	3,300	0
197	PARAMEDICINE GRANT	361,609	361,609	0
201	LATCF - LOCAL ASSISTANCE TRIBAL	510,885	510,885	0
255	NATIONAL FOREST/TITLE III-FIREWISE	145,784	145,784	0
600	ROAD PAVING FUND	5,475,125	5,475,125	0
		<b>49,376,508</b>	<b>49,376,508</b>	<b>0</b>

## Preliminary Taxable Values (2025-2022)

7.2916

Year	Taxabl Value	Millage Rate	Taxes
2025	\$ 1,617,546,892	0.0072916	\$ 11,794,504.92
2024	\$ 1,541,635,799	0.0072916	\$ 11,240,991.59
2023	\$ 1,404,376,317	0.0072916	\$ 10,240,150.35
2022	\$ 1,269,254,257	0.0072916	\$ 9,254,894.34

2,686,542.04 Received in general fund

7,499,266.66 Received in fund 104

---

10,185,808.70 Total

\$ 1,608,696.22 Remaining amount to be received

GENERAL FUND (001) BUDGET REVENUE

ORIGINAL BUDGET WORKSHEET		Past 2 Years Average	2025 Actuals:	2024 Actuals:	Percent Change	Amended Budget	Amended Percent Change	Notes on Amendment
001-311000	AD VALOREM TAXES	1,703,091.67	3,876,027.89	4,053,198.22	3,698,857.55	2,686,542.04		based on property appraiser's estimates
001-311100	DELINQUENT TAXES	1,000.00	65,927.33	15,317.37	116,537.28	1,000.00		
001-312600	DISCRETIONARY SALES TAX	3,071,195.00	2,064,327.79	2,074,071.16	2,054,584.41	3,071,195.00		Estimate provided by dept of revenue
001-312610	POOLED DISCRET. SALES TAX	800,000.00	974,025.66	1,004,127.43	943,923.88	800,000.00		
001-315000	LOCAL COMMUNIC.SERV.TAX	136,614.00	129,509.03	134,813.66	124,204.39	136,614.00		
001-316000	LOCAL BUSINESS TAXES	11,000.00	10,621.47	10,783.12	10,459.82	11,000.00		
<b>Total Taxes:</b>		<b>5,722,900.67</b>	<b>7,120,439.15</b>	<b>7,292,310.96</b>	<b>6,948,567.33</b>	<b>6,706,351.04</b>	<b>-6%</b>	
001-322000	BUILDING PERMITS	330,000.00	206,712.54	248,529.82	164,895.25	330,000.00		
001-322100	SURCHARGE/BLDG. DEPT.	6,000.00	9,520.18	11,879.76	7,160.59	6,000.00		
001-323100	FRANCHISE FEES	650,000.00	757,229.54	793,340.71	721,118.37	650,000.00		
<b>Total Licenses and Permits:</b>		<b>986,000.00</b>	<b>973,462.25</b>	<b>1,053,750.29</b>	<b>893,174.21</b>	<b>986,000.00</b>	<b>1%</b>	
001-333100	DOI/PILT/FEDERAL LANDS	-	233,286.50	248,093.00	218,480.00	-		Program was discontinued
001-333101	PRESERVATION 2000/PILT	120,000.00	129,783.00	129,783.00	129,783.00	120,000.00		
001-334700	STATE AID LIBRARY	52,989.00	46,652.00	47,007.00	46,297.00	52,989.00		
001-335120	COUNTY REVENUE SHARING	817,485.00	853,573.66	857,122.22	850,025.10	817,485.00		
001-335130	INSURANCE AGENT'S LICENSE	70,000.00	55,135.14	82,755.84	27,514.44	70,000.00		
001-335140	MOBILE HOME LICENSE	14,000.00	16,137.42	17,295.38	14,979.45	14,000.00		
001-335150	ALCOHOL BEVERAGE LICENSE	3,000.00	5,489.90	3,188.68	7,791.12	3,000.00		
001-335160	PARI-MUTUEL FUNDS	156,000.00	156,000.00	156,000.00	156,000.00	156,000.00		
001-335180	HALF CENT SALES TAX	1,228,678.00	1,228,226.55	1,222,911.62	1,233,541.47	1,228,678.00		
001-335182	SUPPLEMENTAL INMATE	-	-	-	-	-		
001-335183	EMERGENCY HALF CENT TAX	1,862,605.00	1,938,781.30	1,921,257.30	1,956,305.30	1,862,605.00		
001-335195	FISCALLY CONSTRAINED DIST	290,426.00	271,047.91	263,972.40	278,123.42	290,426.00		
001-335198	AMENDMENT N 1 OFFSET	1,300,000.00	1,368,510.50	1,383,036.00	1,353,985.00	1,300,000.00		
<b>Total Intergovernmental Revenue:</b>		<b>5,915,183.00</b>	<b>6,302,623.87</b>	<b>6,332,422.44</b>	<b>6,272,825.30</b>	<b>5,915,183.00</b>	<b>-6%</b>	
001-342400	RESCUE FEES	1,130,659.00	1,186,137.56	1,043,198.64	1,329,076.47	1,130,659.00		
001-346400	ANIMAL CONTROL FEES	11,000.00	14,940.00	14,365.00	15,515.00	11,000.00		
001-347100	LIBRARY FINES	3,000.00	3,507.70	3,499.76	3,515.63	3,000.00		
001-347300	COPY FEES/PROP.APP	-	309.50	250.00	369.00	-		
<b>Total Charges for Service:</b>		<b>1,144,659.00</b>	<b>1,204,894.75</b>	<b>1,061,313.40</b>	<b>1,348,476.10</b>	<b>1,144,659.00</b>	<b>-5%</b>	
001-341100	BOARD TECHNOLOGY FEES	25,000.00	38,810.11	40,318.00	37,302.21	25,000.00		
001-348480	TITLE IV-D CHILD SUPPORT	-	247.00	494.00	-	-		
<b>Total Court Related Revenue:</b>		<b>25,000.00</b>	<b>39,057.11</b>	<b>40,812.00</b>	<b>37,302.21</b>	<b>25,000.00</b>	<b>-36%</b>	
001-361100	INTEREST	100,000.00	177,660.18	167,608.37	187,711.99	177,660.18		Prior 2 year average
001-362000	RENTALS	2,000.00	2,671.17	1,922.73	3,419.61	2,000.00		
001-362003	RENTAL/POST OFFICE	70,000.00	69,999.96	69,999.96	69,999.96	70,000.00		
001-365000	SALE OF SURPLUS PROPERTY	-	2,822.85	-	5,645.70	-		
001-366100	DONATIONS - LIBRARY	-	-	-	-	-		
001-366210	DONATIONS/ANIMAL CONTROL	2,000.00	5,125.00	2,607.00	7,643.00	2,000.00		
001-369000	MISCELLANEOUS REVENUES	-	23,296.67	58,617.35	(12,024.01)	-		
001-369001	MISCELLANEOUS REV.X	-	-	-	-	-		
001-369060	PRES DRUG CARD FEES	-	-	-	-	-		
001-369102	PLANS REVIEW	50,000.00	50,399.92	59,031.30	41,768.53	50,000.00		
001-369200	INSURANCE REFUNDS	18,500.00	29,043.97	24,337.06	33,750.87	18,500.00		
001-369250	INSURANCE CLAIM REIMB.	-	7,922.11	15,844.22	-	-		
001-369300	MISCELLANEOUS REFUNDS	4,000.00	5,403.40	6,085.07	4,721.73	4,000.00		
001-369320	UTILITY REIMB/RECREATION	3,000.00	2,680.00	1,740.00	3,620.00	3,000.00		
001-369330	POSTAGE REIMBURSEMENTS	3,500.00	4,007.84	-	8,015.67	3,500.00		
<b>Total Misc Revenue:</b>		<b>253,000.00</b>	<b>381,033.06</b>	<b>407,793.06</b>	<b>354,273.05</b>	<b>330,660.18</b>	<b>-13%</b>	
001-367100	CONTRACTOR'S LICENSE	50,000.00	64,364.00	86,639.00	42,089.00	64,364.00		Prior 2 year average
<b>Total Licenses:</b>		<b>50,000.00</b>	<b>64,364.00</b>	<b>86,639.00</b>	<b>42,089.00</b>	<b>64,364.00</b>	<b>-22%</b>	<b>0%</b>
001-331501	FEMA REIMB. FEDERAL SHARE	-	40,786.01	81,572.02	-	-		
001-334510	FEMA REIMB. STATE SHARE	-	-	-	-	-		
001-334511	FEMA REIMB. OTHER SOURCES	-	7,594.78	15,189.56	-	-		
001-381001	TRANSFER IN	-	-	-	-	-		
001-381002	TRANSFER IN	-	-	-	-	-		
001-381003	TRANSFER FROM IMPACT FEES	3,000.00	4,558.21	9,116.42	-	3,000.00		
001-386200	TRANSFER FROM CLERK OF COURT	-	-	-	-	-		
001-386600	TRANS FR PROPERTY APPRSR	55,000.00	48,439.84	8,126.25	88,753.42	55,000.00		
001-386700	TRANS FR TAX COLLECTOR	150,000.00	159,806.49	157,707.62	161,905.36	150,000.00		
001-386800	TRANS FR SUP. ELECTIONS	-	7,063.73	8,126.25	6,001.21	-		
001-386900	TRANSFER FROM SHERIFF	-	-	-	-	-		
<b>Total Other Sources Revenue:</b>		<b>208,000.00</b>	<b>268,249.06</b>	<b>279,838.12</b>	<b>256,659.99</b>	<b>208,000.00</b>	<b>-22%</b>	
<b>TOTAL</b>		<b>14,304,742.67</b>	<b>16,354,123.23</b>	<b>16,554,879.27</b>	<b>16,153,367.19</b>	<b>15,380,217.22</b>		
001-389920	CASH FORWARD	3,649,785.00	-	-	001-389920	CASH FORWARD	-	
001-389941	CASH FORWARD - STATE AID	200,000.00	-	-	001-389941	CASH FORWARD - S	-	
001-389910	LESS 5%	(724,904.73)	-	-	001-389910	LESS 5%	(769,010.86)	
<b>TOTAL</b>		<b>17,429,622.94</b>			<b>TOTAL</b>		<b>14,611,206.36</b>	

GENERAL FUND (001) BUDGET EXPENSES

GL	Expense	Department	Dept. Name	Expense type	Expense type	GL Name	Original Budget	Prior 2 Year Average	2023 Actuals	2024 Actuals	% Change	Amended Budget	Amended Percent Change	Notes on Amendment
001-511-1100-51100	511	1100	COUNTY COMMISSIONERS	51100	EXECUTIVE SALARIES	COUNTY COMMISSIONERS EXECUTIVE SALARIES	180,280.00	184,819.00	187,139.92	182,488.23	2.42%	183,280.00		
001-511-1100-51200	511	1100	COUNTY COMMISSIONERS	51200	SALARIES/FEES	COUNTY COMMISSIONERS REGULAR SALARIES/FEES	454,811.00	513,877.96	515,103.67	512,261.64	299.21%	519,788.16		Increase due to new commissioners joining the board
001-511-1100-51400	511	1100	COUNTY COMMISSIONERS	51400	OVERSIC	COUNTY COMMISSIONERS OVERSIC	1,500.00	1,500.00	1,500.00	1,500.00		1,500.00		
001-511-1100-52100	511	1100	COUNTY COMMISSIONERS	52100	FICA TAXES	COUNTY COMMISSIONERS FICA TAXES	21,748.00	21,447.06	21,359.73	21,345.00		21,345.00		
001-511-1100-52200	511	1100	COUNTY COMMISSIONERS	52200	RETIREMENT - FRIS	COUNTY COMMISSIONERS RETIREMENT - FRIS	146,855.00	155,273.93	154,849.00	153,626.76		146,855.00		
001-511-1100-52300	511	1100	COUNTY COMMISSIONERS	52300	HEALTH INSURANCE	COUNTY COMMISSIONERS HEALTH INSURANCE	40,000.00	78,881.40	78,881.40	78,881.40		40,000.00		
001-511-1100-52301	511	1100	COUNTY COMMISSIONERS	52301	LIFE INSURANCE	COUNTY COMMISSIONERS LIFE INSURANCE	600.00	500.22	500.22	487.56		600.00		
001-511-1100-52302	511	1100	COUNTY COMMISSIONERS	52302	HRA CONTRIBUTION	COUNTY COMMISSIONERS HRA CONTRIBUTION	720.00	645.00	690.00	600.00		720.00		
001-511-1100-52310	511	1100	COUNTY COMMISSIONERS	52310	INSURANCES	COUNTY COMMISSIONERS INSURANCES	41,280.00	41,002.91	41,002.91	42,714.17		40,000.00		
001-511-1100-52400	511	1100	COUNTY COMMISSIONERS	52400	WORKERS COMP	COUNTY COMMISSIONERS WORKERS COMP	226,000.00	6,391.50	6,391.50	12,783.00	3420.30%	226,000.00		
001-511-1100-52500	511	1100	COUNTY COMMISSIONERS	52500	UNEMPLOYMENT INSURANCE	COUNTY COMMISSIONERS UNEMPLOYMENT INSURANCE	5,000.00	5,000.00	5,000.00	5,000.00		5,000.00		
001-511-1100-53100	511	1100	COUNTY COMMISSIONERS	53100	PROFESSIONAL SERVICES	COUNTY COMMISSIONERS PROFESSIONAL SERVICES	10,000.00	3,829.02	3,876.50	3,881.53		10,000.00		
001-511-1100-53110	511	1100	COUNTY COMMISSIONERS	53110	FEMA REIMB	COUNTY COMMISSIONERS FEMA REIMB	-	20,218.50	28,114.60	2,322.29		0.00		
001-511-1100-53120	511	1100	COUNTY COMMISSIONERS	53120	FEMA REIMB	COUNTY COMMISSIONERS FEMA REIMB	-	11,777.00	197.11	22,126.89		0.00		
001-511-1100-53130	511	1100	COUNTY COMMISSIONERS	53130	PROFESSIONAL SERVICES	COUNTY COMMISSIONERS OTHER PROF. SERVICES	-	-	-	-		-		
001-511-1100-53200	511	1100	COUNTY COMMISSIONERS	53200	COUNTY COMMISSIONERS ACCOUNTING	COUNTY COMMISSIONERS ACCOUNTING & AUDITING	98,000.00	159,740.00	217,800.00	105,500.00		98,000.00		
001-511-1100-54000	511	1100	COUNTY COMMISSIONERS	54000	TRAVEL AND PER DIEM	COUNTY COMMISSIONERS TRAVEL AND PER DIEM	2,500.00	-	-	-		2,500.00		
001-511-1100-54100	511	1100	COUNTY COMMISSIONERS	54100	COMMUNICATIONS	COUNTY COMMISSIONERS COMMUNICATIONS	11,000.00	10,887.71	10,860.36	10,516.06		11,000.00		
001-511-1100-54200	511	1100	COUNTY COMMISSIONERS	54200	POSTAGE	COUNTY COMMISSIONERS POSTAGE	20,000.00	20,626.12	24,454.09	17,716.15		20,000.00		
001-511-1100-54300	511	1100	COUNTY COMMISSIONERS	54300	ELECTRIC	COUNTY COMMISSIONERS ELECTRIC	6,500.00	6,031.79	6,031.79	5,800.23		6,500.00		
001-511-1100-54302	511	1100	COUNTY COMMISSIONERS	54302	WATER	COUNTY COMMISSIONERS WATER	672.00	687.56	684.74	668.18		672.00		
001-511-1100-54400	511	1100	COUNTY COMMISSIONERS	54400	UTILITIES/GAS	COUNTY COMMISSIONERS UTILITIES/GAS	-	-	-	-		-		
001-511-1100-54500	511	1100	COUNTY COMMISSIONERS	54500	RENTALS AND LEASES	COUNTY COMMISSIONERS RENTALS AND LEASES	5,350.00	4,892.87	4,891.55	4,684.38		5,350.00		
001-511-1100-54600	511	1100	COUNTY COMMISSIONERS	54600	INSURANCE CARRIER	COUNTY COMMISSIONERS INSURANCE CARRIER	228,000.00	286,051.06	394,589.84	175,522.80		228,000.00		
001-511-1100-54601	511	1100	COUNTY COMMISSIONERS	54601	INSURANCE CLAIMS DEDUCT	COUNTY COMMISSIONERS INSURANCE CLAIMS DEDUCT	2,392.52	-	-	-		2,392.52		
001-511-1100-54602	511	1100	COUNTY COMMISSIONERS	54602	REPAIRS/MAINT	COUNTY COMMISSIONERS REPAIRS AND MAINTENANCE	4,500.00	1,265.48	1,543.16	1,047.80		4,500.00		
001-511-1100-54603	511	1100	COUNTY COMMISSIONERS	54603	REPAIRS/MAINT	COUNTY COMMISSIONERS VEHICLE REPAIRS & MAINT.	1,000.00	311.10	363.72	268.47		1,000.00		
001-511-1100-54604	511	1100	COUNTY COMMISSIONERS	54604	OTHER CURRENT CHARGES	COUNTY COMMISSIONERS OTHER CURRENT CHARGES	-	-	-	-		-		
001-511-1100-54901	511	1100	COUNTY COMMISSIONERS	54901	ADVERTISING	COUNTY COMMISSIONERS ADVERTISING	2,000.00	3,130.11	3,430.59	2,829.62		2,000.00		
001-511-1100-54902	511	1100	COUNTY COMMISSIONERS	54902	ACTIVITIES	COUNTY COMMISSIONERS ACTIVITIES	-	375.00	750.00	-		-		
001-511-1100-54903	511	1100	COUNTY COMMISSIONERS	54903	RECORDING FEES	COUNTY COMMISSIONERS RECORDING FEES	700.00	802.19	802.19	676.50		700.00		
001-511-1100-54910	511	1100	COUNTY COMMISSIONERS	54910	REFUNDS	COUNTY COMMISSIONERS REFUNDS	-	-	-	-		-		
001-511-1100-55100	511	1100	COUNTY COMMISSIONERS	55100	OFFICE SUPPLIES	COUNTY COMMISSIONERS OFFICE SUPPLIES	3,000.00	4,320.46	5,718.43	2,922.49		3,000.00		
001-511-1100-55110	511	1100	COUNTY COMMISSIONERS	55110	OPERATING SUPPLIES	COUNTY COMMISSIONERS OPERATING SUPPLIES	8,000.00	8,207.49	8,207.49	8,000.00		8,000.00		
001-511-1100-55211	511	1100	COUNTY COMMISSIONERS	55211	FUEL	COUNTY COMMISSIONERS FUEL	900.00	520.71	105.66	935.75		900.00		
001-511-1100-55212	511	1100	COUNTY COMMISSIONERS	55212	TALES FEES	COUNTY COMMISSIONERS TALES FEES	100.00	25.00	56.13	40.32		100.00		
001-511-1100-55214	511	1100	COUNTY COMMISSIONERS	55214	CREDIT CARD FEES EXP	COUNTY COMMISSIONERS CREDIT CARD FEES EXP	50.00	45.00	50.00	50.00		50.00		
001-511-1100-55400	511	1100	COUNTY COMMISSIONERS	55400	BOOKS/PUBL/MEMBERSHIPS	COUNTY COMMISSIONERS BOOKS/PUBL/MEMBERSHIPS	1,200.00	250.00	85.00	425.00		1,200.00		
001-511-1100-55500	511	1100	COUNTY COMMISSIONERS	55500	TRAINING	COUNTY COMMISSIONERS TRAINING	1,500.00	-	-	-		1,500.00		
001-511-1100-56000	511	1100	COUNTY COMMISSIONERS	56000	BUILDINGS	COUNTY COMMISSIONERS BUILDINGS	-	-	-	-		-		
001-511-1100-56001	511	1100	COUNTY COMMISSIONERS	56001	IMPROVEMENTS	COUNTY COMMISSIONERS IMPROVEMENTS	-	-	-	-		-		
001-511-1100-56400	511	1100	COUNTY COMMISSIONERS	56400	EQUIPMENT	COUNTY COMMISSIONERS EQUIPMENT	2,000.00	7,560.00	720.00	14,400.00		2,000.00		
001-511-1100-56401	511	1100	COUNTY COMMISSIONERS	56401	VEHICLE	COUNTY COMMISSIONERS VEHICLE	1,394,018.00	1,299.99	299.98	3,200.00		1,394,018.00		
001-511-1100-56402	511	1100	COUNTY COMMISSIONERS	56402	OFFICE FURNITURE	COUNTY COMMISSIONERS OFFICE FURNITURE	-	-	-	-		-		
<b>Total County Commissioners</b>							<b>2,934,018.00</b>	<b>1,119,613.74</b>	<b>1,300,993.54</b>	<b>837,873.89</b>	<b>52%</b>	<b>1,284,232.16</b>	<b>13%</b>	<b>FF 25th Contract amend</b>
001-512-1200-91180	512	1200	CLERK TO BOARD	91180	TRANS/CONSTR. OFFICER	CLERK TO BOARD TRANS/CONSTR. OFFICER	619,935.75	493,177.82	510,545.63	478,210.00		619,935.75		
<b>Total Clerk to Board</b>							<b>619,935.75</b>	<b>493,177.82</b>	<b>510,545.63</b>	<b>478,210.00</b>	<b>26%</b>	<b>619,935.75</b>	<b>65%</b>	
001-513-1300-52100	513	1300	HR	52100	SALARIES/FEES	HUMAN RESOURCES REGULAR SALARIES/FEES	90,489.00	94,286.14	95,729.76	90,489.00		90,489.00		
001-513-1300-52101	513	1300	HR	52101	FICA TAXES	HUMAN RESOURCES FICA TAXES	6,922.00	6,808.67	7,157.96	6,429.38		6,922.00		
001-513-1300-52200	513	1300	HR	52200	RETIREMENT - FRIS	HUMAN RESOURCES RETIREMENT - FRIS	12,334.00	12,120.87	12,120.87	12,120.87		12,334.00		
001-513-1300-52300	513	1300	HR	52300	HEALTH INSURANCE	HUMAN RESOURCES HEALTH INSURANCE	6,333.00	7,274.79	6,183.90	8,365.67		6,333.00		
001-513-1300-52301	513	1300	HR	52301	LIFE INSURANCE	HUMAN RESOURCES LIFE INSURANCE	78.00	87.75	102.50	75.00		78.00		
001-513-1300-52302	513	1300	HR	52302	HRA CONTRIBUTION	HUMAN RESOURCES HRA CONTRIBUTION	128.00	120.00	120.00	120.00		128.00		
001-513-1300-54000	513	1300	HR	54000	TRAVEL AND PER DIEM	HUMAN RESOURCES TRAVEL AND PER DIEM	125.00	-	-	-		125.00		
001-513-1300-54100	513	1300	HR	54100	COMMUNICATIONS	HUMAN RESOURCES COMMUNICATIONS	500.00	441.61	479.26	403.98		500.00		
001-513-1300-55100	513	1300	HR	55100	OFFICE SUPPLIES	HUMAN RESOURCES OFFICE SUPPLIES	1,000.00	945.29	945.29	934.84		1,000.00		
001-513-1300-55210	513	1300	HR	55210	OPERATING SUPPLIES	HUMAN RESOURCES OPERATING SUPPLIES	150.00	103.02	146.11	89.92		150.00		
001-513-1300-55211	513	1300	HR	55211	FUEL	HUMAN RESOURCES FUEL	75.00	25.00	50.00	75.00		75.00		
001-513-1300-55500	513	1300	HR	55500	TRAINING	HUMAN RESOURCES TRAINING	1,500.00	25.00	12.50	50.00		1,500.00		
001-513-1300-56000	513	1300	HR	56000	EQUIPMENT	HUMAN RESOURCES EQUIPMENT	300.00	445.72	891.43	-		300.00		
001-513-1300-56402	513	1300	HR	56402	OFFICE FURNITURE	HUMAN RESOURCES OFFICE FURNITURE	10,000.00	-	-	-		10,000.00		
<b>Total Human Resources</b>							<b>282,335.00</b>	<b>118,565.75</b>	<b>122,826.25</b>	<b>114,154.25</b>	<b>18%</b>	<b>118,574.00</b>	<b>0%</b>	
001-513-1300-56001	513	1300	FINANCE AND BUDGET	56001	REPAIRS AND MAINTENANCE	FINANCE AND BUDGET REPAIRS AND MAINTENANCE	2,500.00	1,023.89	1,580.17	1,064.31		2,500.00		
001-513-1300-56002	513	1300	FINANCE AND BUDGET	56002	OFFICE SUPPLIES	FINANCE AND BUDGET OFFICE SUPPLIES	1,000.00	521.82	903.75	139.89		1,000.00		
001-513-1300-56210	513	1300	FINANCE AND BUDGET	56210	OPERATING SUPPLIES	FINANCE AND BUDGET OPERATING SUPPLIES	1,000.00	521.82	903.75	139.89		1,000.00		
001-513-1300-56400	513	1300	FINANCE AND BUDGET	56400	EQUIPMENT	FINANCE AND BUDGET EQUIPMENT	17,500.00	12,110.50	12,405.00	11,818.00		17,500.00		ADG maintenance fee
001-513-1300-56401	513	1300	FINANCE AND BUDGET	56401	SOFTWARE LICENSES	FINANCE AND BUDGET SOFTWARE LICENSES/CAPITAL	2,000.00	-	-	-		2,000.00		
<b>Total Finance</b>							<b>21,000.00</b>	<b>13,966.21</b>	<b>14,902.22</b>	<b>13,000.20</b>	<b>50%</b>	<b>21,000.00</b>	<b>50%</b>	
001-513-1400-54000	513	1400	PROPERTY APPRAISER	54000	REPAIRS AND MAINTENANCE	PRIORITY APPRAISER REPAIRS AND MAINTENANCE	1,000.00	977.46	638.41	1,350.50		1,000.00		
001-513-1400-54010	513	1400	PROPERTY APPRAISER	54010	REPAIRS/MAINT	PRIORITY APPRAISER BUILDING MAINTENANCE	2,000.00	1,888.88						



001-564-3510-54307	564	3510	HUMAN SERVICES EXPENSES	54307	ELECTRIC	HUMAN SERVICES EXPENSES ELECTRIC/TRANSP CENTER	17,500.00	15,475.92	16,114.02	14,837.81	17,500.00	
001-564-3510-54402	564	3510	HUMAN SERVICES EXPENSES	54400	RENTALS AND LEASES	HUMAN SERVICES EXPENSES RENTALS AND LEASES	-	-	-	-	-	
001-564-3510-54408	564	3510	HUMAN SERVICES EXPENSES	54408	REPAIRS/MAINT	HUMAN SERVICES EXPENSES TOGA REPAIR & MAINT	5,000.00	7,267.57	8,979.42	5,565.71	5,000.00	
001-564-3510-54410	564	3510	HUMAN SERVICES EXPENSES	54410	REPAIRS/MAINT	HUMAN SERVICES EXPENSES HEALTH DEPT. REP & MAINT	1,000.00	11,965.19	15,367.32	8,565.05	1,000.00	
001-564-3510-54416	564	3510	HUMAN SERVICES EXPENSES	54416	REPAIRS/MAINT	HUMAN SERVICES EXPENSES COT SERV BLDG REP & MAINT	1,000.00	1,000.00	964.08	47.58	1,000.00	
001-564-3510-54400	564	3510	HUMAN SERVICES EXPENSES	54000	OTHER CURRENT CHARGES	HUMAN SERVICES EXPENSES OTHER CURRENT CHARGES	-	-	-	-	-	
001-564-3510-54403	564	3510	HUMAN SERVICES EXPENSES	54020	INDIDENT MEDICINE	HUMAN SERVICES EXPENSES INDIDENT MEDICINE	1,000.00	-	-	-	1,000.00	
001-564-3510-54490	564	3510	HUMAN SERVICES EXPENSES	54090	HUMAN SERVICES EXPENSES MEDICATION	HUMAN SERVICES EXPENSES MEDICATION/DRUGS HOME	500,000.00	527,131.57	566,476.77	493,766.37	500,000.00	
001-564-3510-58104	564	3510	HUMAN SERVICES EXPENSES	58104	HUMAN SERVICES EXPENSES COUNCIL ON AGING	HUMAN SERVICES EXPENSES COUNCIL ON AGING	140,000.00	135,000.00	135,000.00	135,000.00	140,000.00	
001-564-3510-58105	564	3510	HUMAN SERVICES EXPENSES	58105	MENTAL HEALTH MATCH	HUMAN SERVICES EXPENSES MENTAL HEALTH MATCH	-	-	-	-	-	
001-564-3510-58107	564	3510	HUMAN SERVICES EXPENSES	58107	HUMAN SERVICES EXPENSES MENTAL HEALTH MATCH	HUMAN SERVICES EXPENSES MENTAL HEALTH MATCH	-	-	-	-	-	
001-564-3510-58110	564	3510	HUMAN SERVICES EXPENSES	58110	HUMAN SERVICES EXPENSES MENTAL HEALTH MATCH	HUMAN SERVICES EXPENSES MENTAL HEALTH MATCH	66,365.00	82,915.00	66,365.00	98,865.00	66,365.00	
001-564-3510-58115	564	3510	HUMAN SERVICES EXPENSES	58115	HEALTH DEPT. MATCH	HUMAN SERVICES EXPENSES HEALTH DEPT. MATCH	66,000.00	60,884.00	66,000.00	55,728.00	66,000.00	
001-564-3510-58200	564	3510	HUMAN SERVICES EXPENSES	58200	HUMAN SERVICES EXPENSES EPISCOPAL CH	HUMAN SERVICES EXPENSES EPISCOPAL CH	1,500.00	1,575.00	1,650.00	1,500.00	1,500.00	
001-564-3510-58202	564	3510	HUMAN SERVICES EXPENSES	58202	HUMAN SERVICES EXPENSES THE ARC N. FL.	HUMAN SERVICES EXPENSES THE ARC N. FL.	7,500.00	11,250.00	7,500.00	15,000.00	7,500.00	
001-564-3510-58225	564	3510	HUMAN SERVICES EXPENSES	58225	FIRE WATCH	HUMAN SERVICES EXPENSES FIRE WATCH COUNCIL	-	-	-	3,000.00	-	
<b>Total Human Services Expense</b>							<b>824,346.00</b>	<b>876,000.00</b>	<b>907,929.00</b>	<b>844,672.19</b>	<b>824,346.00</b>	<b>-6%</b>
001-586-3520-59100	586	3520	MISCELLANEOUS EXPENSES	59100	MISCELLANEOUS EXPENSES TRANSFER OUT	MISCELLANEOUS EXPENSES TRANSFER OUT	37,998.00	28,499.00	37,998.00	15,000.00	-	don't need
001-586-3520-59110	586	3520	MISCELLANEOUS EXPENSES	59110	MISCELLANEOUS EXPENSES TRANSFER OUT	MISCELLANEOUS EXPENSES TRANSFER OUT	-	-	-	-	225,547.22	had to increase this so that fund 123 would balance
001-581-3520-59101	581	3520	MISCELLANEOUS EXPENSES	59101	MISCELLANEOUS EXPENSES TRANSFER TO SOLID WASTE	MISCELLANEOUS EXPENSES TRANSFER TO SOLID WASTE	466,396.25	291,500.00	440,000.00	143,000.00	600,773.73	had to increase this so that fund 116 would balance
001-581-3520-59102	581	3520	MISCELLANEOUS EXPENSES	59102	MISCELLANEOUS EXPENSES TRANSFER TO SPECIAL FIRE	MISCELLANEOUS EXPENSES TRANSFER TO SPECIAL FIRE	81,100.00	40,500.00	-	81,100.00	-	Don't need transfer from gen rev, fund 104 balances
001-586-3520-59103	586	3520	MISCELLANEOUS EXPENSES	59103	MISCELLANEOUS EXPENSES TRANSFER TO TOWN & FOREST	MISCELLANEOUS EXPENSES TRANSFER TO TOWN & FOREST	4,128,800.00	2,238,200.00	3,806,400.00	2,000,000.00	4,951,133.89	had to increase this so that fund 104 would balance
001-581-3520-59105	581	3520	MISCELLANEOUS EXPENSES	59105	MISCELLANEOUS EXPENSES TRANSFER TO	MISCELLANEOUS EXPENSES TRANSFER TO	354,563.67	117,610.50	-	235,221.00	1,763,622.29	had to increase this so that fund 105 would balance
001-586-3520-59106	586	3520	MISCELLANEOUS EXPENSES	59106	MISCELLANEOUS EXPENSES TRANSFER TO ROAD AND BRIDGE	MISCELLANEOUS EXPENSES TRANSFER TO ROAD AND BRIDGE	-	-	-	-	360,000.00	had to add this so that fund 103 would balance
001-586-3520-59108	586	3520	MISCELLANEOUS EXPENSES	59108	MISCELLANEOUS EXPENSES TRANSFER TO	MISCELLANEOUS EXPENSES TRANSFER TO	57,871.00	57,871.00	57,871.00	57,871.00	-	Don't need transfer from gen rev, fund 108 balance
<b>Total Misc</b>							<b>5,126,816.92</b>	<b>3,362,236.50</b>	<b>4,142,269.00</b>	<b>2,582,192.00</b>	<b>7,876,131.14</b>	<b>154%</b>
001-571-3600-52100	571	3600	STATE AID - LIBRARY	52100	SALARIES/WAGES	STATE AID - LIBRARY REGULAR SALARIES/WAGES	25,490.00	23,029.38	25,063.55	20,996.20	25,490.00	
001-571-3600-52101	571	3600	STATE AID - LIBRARY	52101	FICA TAXES	STATE AID - LIBRARY FICA TAXES	1,950.00	1,761.76	1,917.37	1,659.14	1,950.00	
001-571-3600-52200	571	3600	STATE AID - LIBRARY	52200	RETIREMENT - FRB	STATE AID - LIBRARY RETIREMENT - FRB	3,474.00	2,848.83	3,413.97	2,283.69	3,474.00	
001-571-3600-52300	571	3600	STATE AID - LIBRARY	52300	HEALTH INSURANCE	STATE AID - LIBRARY HEALTH INSURANCE	-	99.21	120.05	78.37	-	
001-571-3600-52301	571	3600	STATE AID - LIBRARY	52301	LIFE INSURANCE	STATE AID - LIBRARY LIFE INSURANCE	150.00	-	-	-	150.00	
001-571-3600-52302	571	3600	STATE AID - LIBRARY	52302	HRA CONTRIBUTION	STATE AID - LIBRARY HRA CONTRIBUTION	-	-	-	-	-	
001-571-3600-52300	571	3600	STATE AID - LIBRARY	52300	OTHER CONTRACTUAL	STATE AID - LIBRARY OTHER CONTRACTUAL	-	-	-	-	-	
001-571-3600-54000	571	3600	STATE AID - LIBRARY	54000	TRAVEL AND PER DIEM	STATE AID - LIBRARY TRAVEL AND PER DIEM	-	-	-	-	-	
001-571-3600-54200	571	3600	STATE AID - LIBRARY	54200	POSTAGE	STATE AID - LIBRARY POSTAGE	400.00	36.50	-	73.00	400.00	
001-571-3600-54400	571	3600	STATE AID - LIBRARY	54400	RENTALS AND LEASES	STATE AID - LIBRARY RENTALS AND LEASES	2,000.00	-	-	-	2,000.00	
001-571-3600-54600	571	3600	STATE AID - LIBRARY	54600	REPAIRS AND MAINTENANCE	STATE AID - LIBRARY REPAIRS AND MAINTENANCE	2,000.00	-	-	-	2,000.00	
001-571-3600-54901	571	3600	STATE AID - LIBRARY	54901	ADVERTISING	STATE AID - LIBRARY ADVERTISING	100.00	94.50	-	189.00	100.00	
001-571-3600-55100	571	3600	STATE AID - LIBRARY	55100	OFFICE SUPPLIES	STATE AID - LIBRARY OFFICE SUPPLIES	800.00	338.09	672.18	800.00	800.00	
001-571-3600-55210	571	3600	STATE AID - LIBRARY	55210	OPERATING SUPPLIES	STATE AID - LIBRARY OPERATING SUPPLIES	5,000.00	1,258.92	1,495.30	1,022.54	5,000.00	
001-571-3600-55400	571	3600	STATE AID - LIBRARY	55400	BOOKS/PUB MEMBERSHIPS	STATE AID - LIBRARY BOOKS/PUB MEMBERSHIPS	-	-	-	-	-	
001-571-3600-56400	571	3600	STATE AID - LIBRARY	56400	EQUIPMENT	STATE AID - LIBRARY EQUIPMENT	-	-	-	-	-	
001-571-3600-56600	571	3600	STATE AID - LIBRARY	56600	LIBRARY MATERIALS	STATE AID - LIBRARY BOOKS, LIBRARY MATERIALS	15,000.00	2,273.58	607.26	3,939.90	15,000.00	
<b>Total State Aid - Library</b>							<b>55,445.00</b>	<b>31,738.76</b>	<b>31,289.67</b>	<b>30,187.84</b>	<b>55,445.00</b>	<b>75%</b>
001-522-3700-58106	522	3700	GRANTS DEPARTMENT	58106	MISCELLANEOUS EXPENSES FIRE CONTROL	MISCELLANEOUS EXPENSES FIRE CONTROL EXPENSES	15,900.00	15,898.48	15,898.48	15,898.48	15,900.00	
<b>Total Grants Dept</b>							<b>15,900.00</b>	<b>15,898.48</b>	<b>15,898.48</b>	<b>15,898.48</b>	<b>15,900.00</b>	<b>0%</b>
001-516-4000-51200	516	4000	INFORMATION SYSTEMS	51200	SALARIES/WAGES	INFORMATION SYSTEMS REGULAR SALARIES/WAGES	184,008.00	178,205.91	177,705.68	170,615.13	184,008.00	
001-516-4000-51400	516	4000	INFORMATION SYSTEMS	51400	OVERTIME	INFORMATION SYSTEMS OVERTIME	227.12	13.23	13.23	441.00	-	
001-516-4000-52100	516	4000	INFORMATION SYSTEMS	52100	FICA TAXES	INFORMATION SYSTEMS FICA TAXES	14,077.00	13,396.00	13,357.28	13,435.92	14,077.00	
001-516-4000-52200	516	4000	INFORMATION SYSTEMS	52200	RETIREMENT - FRB	INFORMATION SYSTEMS RETIREMENT - FRB	25,368.00	24,727.95	24,191.40	25,284.49	25,000.00	
001-516-4000-52300	516	4000	INFORMATION SYSTEMS	52300	HEALTH INSURANCE	INFORMATION SYSTEMS HEALTH INSURANCE	19,000.00	20,021.34	18,116.99	23,725.68	19,000.00	
001-516-4000-52301	516	4000	INFORMATION SYSTEMS	52301	LIFE INSURANCE	INFORMATION SYSTEMS LIFE INSURANCE	225.00	219.25	213.50	225.00	225.00	
001-516-4000-52302	516	4000	INFORMATION SYSTEMS	52302	HRA CONTRIBUTION	INFORMATION SYSTEMS HRA CONTRIBUTION	360.00	-	-	360.00	360.00	
001-516-4000-54000	516	4000	INFORMATION SYSTEMS	54000	TRAVEL AND PER DIEM	INFORMATION SYSTEMS TRAVEL AND PER DIEM	-	-	-	-	-	
001-516-4000-54100	516	4000	INFORMATION SYSTEMS	54100	COMMUNICATIONS	INFORMATION SYSTEMS COMMUNICATIONS	26,000.00	23,992.38	26,141.22	20,643.54	26,000.00	
001-516-4000-54600	516	4000	INFORMATION SYSTEMS	54600	INSURANCE CLAIMS	DISPOS INSURANCE CLAIMS, DEDUCT	-	1,842.60	-	3,685.20	-	
001-516-4000-54800	516	4000	INFORMATION SYSTEMS	54800	REPAIRS AND MAINTENANCE	INFORMATION SYSTEMS REPAIRS AND MAINTENANCE	-	78.49	151.97	-	-	
001-516-4000-54902	516	4000	INFORMATION SYSTEMS	54902	REPAIRS/MAINT	INFORMATION SYSTEMS VEHICLE REPAIRS & MAINT	1,000.00	78.67	141.84	-	1,000.00	
001-516-4000-54903	516	4000	INFORMATION SYSTEMS	54903	REPAIRS/MAINT	INFORMATION SYSTEMS EQUIPMENT REPAIRS & MAINT	13,000.00	1,630.57	2,527.14	734.00	13,000.00	
001-516-4000-54901	516	4000	INFORMATION SYSTEMS	54901	ADVERTISING	INFORMATION SYSTEMS ADVERTISING	-	62.09	124.18	-	-	
001-516-4000-55210	516	4000	INFORMATION SYSTEMS	55210	OPERATING SUPPLIES	INFORMATION SYSTEMS OPERATING SUPPLIES	5,000.00	7,708.56	13,024.77	1,816.34	5,000.00	
001-516-4000-55211	516	4000	INFORMATION SYSTEMS	55211	FUEL	INFORMATION SYSTEMS FUEL	900.00	759.93	439.90	1,079.98	900.00	
001-516-4000-55400	516	4000	INFORMATION SYSTEMS	55400	BOOKS/PUB MEMBERSHIPS	INFORMATION SYSTEMS BOOKS/PUB MEMBERSHIPS	-	997.50	1,995.00	-	-	
001-516-4000-55500	516	4000	INFORMATION SYSTEMS	55500	TRAINING	INFORMATION SYSTEMS TRAINING	8,000.00	1,773.38	465.39	3,141.30	8,000.00	
001-516-4000-56200	516	4000	INFORMATION SYSTEMS	56200	BUILDINGS	INFORMATION SYSTEMS BUILDINGS	-	-	-	-	-	
001-516-4000-56400	516	4000	INFORMATION SYSTEMS	56400	EQUIPMENT	INFORMATION SYSTEMS EQUIPMENT	20,190.00	3,225.78	958.82	5,492.73	37,580.00	includes BK for leases
001-516-4000-56452	516	4000	INFORMATION SYSTEMS	56452	OFFICE FURNITURE	INFORMATION SYSTEMS OFFICE FURNITURE	-	-	-	-	-	
001-516-4000-56455	516	4000	INFORMATION SYSTEMS	56455	SOFTWARE LICENSES	INFORMATION SYSTEMS SOFTWARE LICENSES-CAPITAL	437,890.00	32,847.73	26,818.98	39,076.48	77,000.00	
<b>Total Information Systems</b>							<b>794,718.00</b>	<b>515,647.74</b>	<b>506,207.96</b>	<b>314,667.57</b>	<b>411,228.00</b>	<b>32%</b>
001-721-9300-64100	721	9300	COUNTY JUDGE	64100	COMMUNICATIONS	COUNTY JUDGE COMMUNICATIONS	500.00	309.66	771.14	281.18	500.00	
001-721-9300-65210	721	9300	COUNTY JUDGE	65210	OPERATING SUPPLIES	COUNTY JUDGE OPERATING SUPPLIES	1,000.00	1,316.50	707.79	1,925.21	1,000.00	
001-721-9300-65500	721	9300	COUNTY JUDGE	65500	TRAINING	COUNTY JUDGE TRAINING	2,000.00	-	-	-	2,000.00	
<b>Total County Judge</b>							<b>4,900.00</b>	<b>1,586.16</b>	<b>978.93</b>	<b>2,193.39</b>	<b>4,500.00</b>	<b>184%</b>
<b>TOTAL</b>							<b>23,975,776.67</b>	<b>13,846,685.31</b>	<b>15,222,149.10</b>	<b>12,471,221.51</b>	<b>18,473,534.93</b>	

**GENERAL FUND (001) BUDGET REVENUE**

REVENUE TYPE	ORIGINAL BUDGET	Past 2 Years Average	2025 Actuals:	2024 Actuals:	Percent Change	Amended Budget	Amended Percent Change	Notes on Amendment
<b>Total Taxes:</b>	5,722,900.67	7,120,439.15	7,292,310.96	6,948,567.33	-20%	6,706,351.04	-6%	
<b>Total Licenses and Permits:</b>	986,000.00	973,462.25	1,053,750.29	893,174.21	1%	986,000.00	1%	
<b>Total Intergovernmental Revenue:</b>	5,915,183.00	6,302,623.87	6,332,422.44	6,272,825.30	-6%	5,915,183.00	-6%	
<b>Total Charges for Service:</b>	1,144,659.00	1,204,894.75	1,061,313.40	1,348,476.10	-5%	1,144,659.00	-5%	
<b>Total Court Related Revenue:</b>	25,000.00	39,057.11	40,812.00	37,302.21	-36%	25,000.00	-36%	
<b>Total Misc Revenue:</b>	253,000.00	381,033.06	407,793.06	354,273.05	-34%	330,660.18	-13%	
<b>Total Licenses:</b>	50,000.00	64,364.00	86,639.00	42,089.00	-22%	64,364.00	0%	
<b>Total Other Sources Revenue:</b>	208,000.00	268,249.06	279,838.12	256,659.99	-22%	208,000.00	-22%	
<b>TOTAL</b>	<b>14,304,742.67</b>	<b>16,354,123.23</b>	<b>16,554,879.27</b>	<b>16,153,367.19</b>		<b>15,380,217.22</b>		
001-389920 CASH FORWARD	3,649,785.00			001-389920 CASH FORWARD		-		
001-389941 CASH FORWARD - STATE AID	200,000.00			001-389941 CASH FORWARD - S		-		
001-389910 LESS 5%	(724,904.73)			001-389910 LESS 5%		(769,010.86)		
<b>TOTAL</b>	<b>17,429,622.94</b>			<b>TOTAL</b>		<b>14,611,206.36</b>		

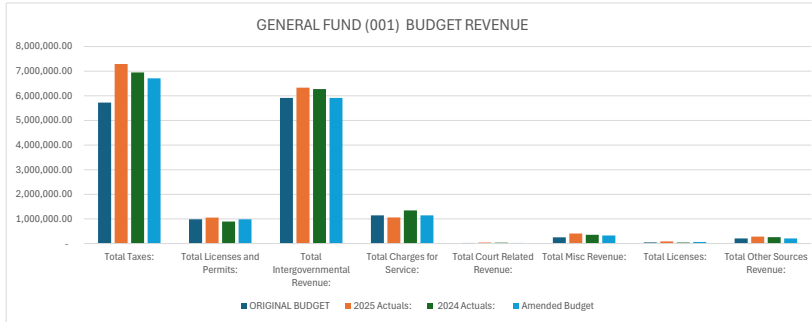

Dept	Original Budget	Prior 2 Year Average	2025 Actuals
------	-----------------	----------------------	--------------

County Commissioners	2,934,014.00	1,119,910.74	1,300,903.54
Clerk to Board	619,933.75	493,177.82	510,145.63
Human Resources	282,135.00	118,505.75	122,820.25
Finance	21,000.00	13,956.21	14,902.22
Property Appraiser	884,165.00	831,068.56	853,748.47
Tax Collector	767,139.00	746,324.11	799,707.55
State Attorney	88,993.00	39,269.12	46,274.48
Public Defender	37,793.00	12,036.12	12,188.41
Legal Counsel	70,040.00	69,822.50	73,645.00
Clerk of Court Communication	300.00	269.66	271.14
Clerk of Supervisor of Elections	770,754.00	741,560.57	783,320.10
Clerk of Courthouse Expenses	144,700.00	164,829.65	160,473.10
Facilities Maintenance	1,146,328.00	345,805.04	303,454.68
Circuit Court Pro Rata	80,300.00	62,520.04	57,649.60
Guardian Ad Litem	10,700.00	7,937.55	8,548.75
Community Development	1,170,598.00	398,237.32	383,521.15
EMS	5,877,020.00	2,950,648.28	3,189,390.39
Extension Service	529,901.00	188,587.52	180,240.66
Guardian Ag Center	67,599.00	21,122.98	23,041.22
Verteran's Services	92,112.00	42,502.76	42,872.78
Library	349,697.00	168,263.16	180,624.95
Recreation	849,881.00	383,660.19	442,509.38
Comm Center/Recreation	65,600.00	65,697.20	48,334.61
Animal Control	248,514.00	179,363.89	187,858.26
Economic Environment	85,836.00	82,510.40	86,129.80
Human Services Expense	824,340.00	876,000.60	907,929.00
Transfers	5,125,816.92	3,362,230.50	4,142,269.00
State Aid	55,443.00	31,738.76	33,289.67
Grants Dept	15,900.00	15,894.48	15,898.48
Information Systems	754,718.00	311,647.74	309,207.90
County Judge	4,500.00	1,586.16	978.93

2024 Actuals	% Change	Amended Budget	Amended Percent Change	Notes on Amendment
938,917.93	162%	1,264,222.16	13%	
476,210.00	26%	805,293.00	63%	
114,191.25	138%	118,574.00	0%	
13,010.20	50%	21,000.00	50%	
808,388.65	6%	884,165.00	6%	
692,940.67	3%	767,139.00	3%	
32,263.75	127%	88,993.00	127%	
11,883.82	214%	37,793.00	214%	
66,000.00	0%	70,040.00	0%	
268.18	11%	300.00	11%	
699,801.03	4%	770,754.00	4%	
169,186.20	-12%	144,700.00	-12%	
388,155.40	231%	462,346.63	34%	
67,390.48	28%	80,300.00	28%	
7,326.34	35%	10,700.00	35%	
412,953.48	194%	696,427.00	30%	
2,711,906.16	99%	2,786,708.00	-6%	
196,934.37	181%	224,928.00	19%	
19,204.73	220%	34,127.00	62%	
42,132.74	117%	45,004.00	6%	
155,901.36	108%	168,699.00	0%	
324,810.99	122%	403,854.00	5%	
83,059.79	0%	65,600.00	0%	
170,869.52	39%	248,514.00	39%	
78,891.00	4%	85,836.00	4%	
844,072.19	-6%	824,340.00	-6%	
2,582,192.00	52%	7,876,107.14	135%	
30,187.84	75%	55,443.00	75%	
15,890.48	0%	15,900.00	0%	
314,087.57	142%	411,228.00	32%	
2,193.39	184%	4,500.00	184%	

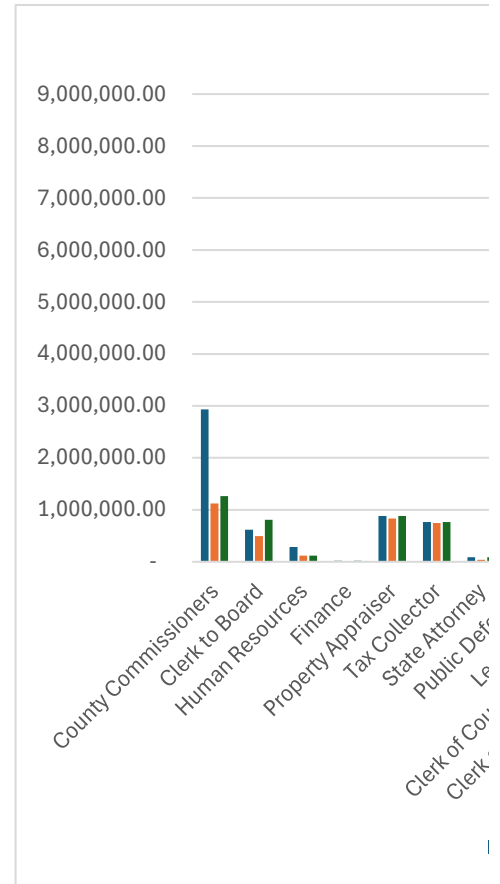

## GENERAL FUND (001) BUDGET EXPENSES

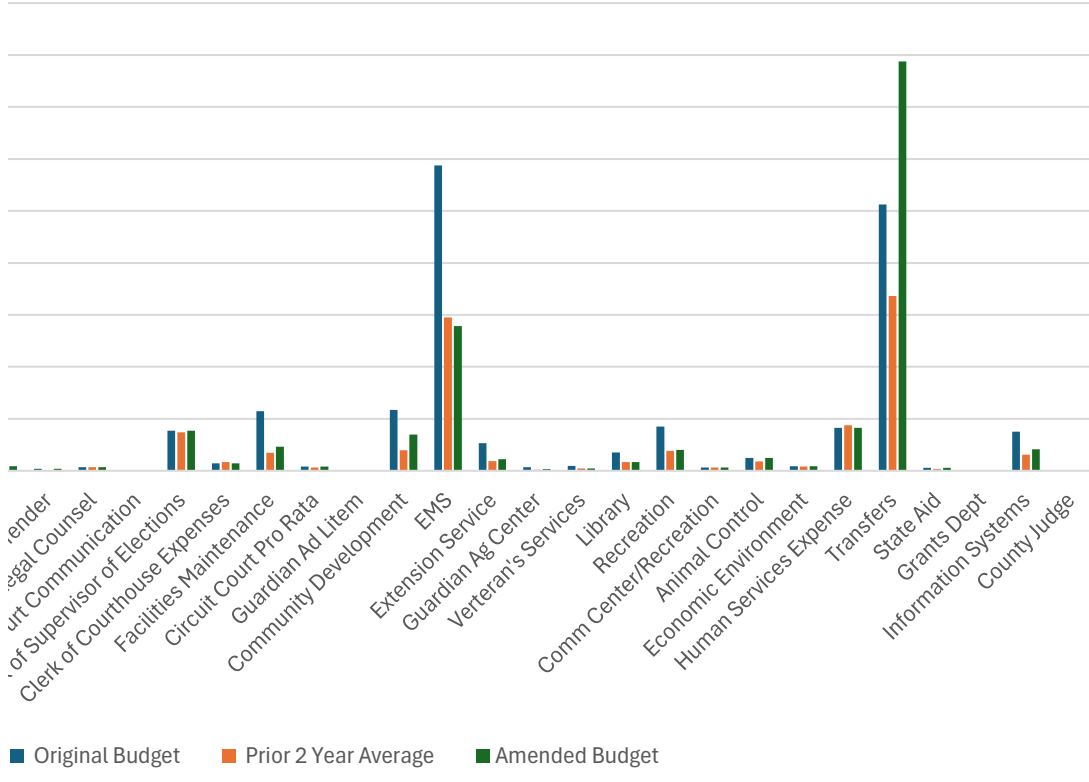



**BAKER COUNTY BOARD OF COUNTY COMMISSIONERS**  
**AGENDA ITEM REQUEST FORM**

The Board of County Commissioners meet on the 1<sup>st</sup> and 3<sup>rd</sup> Tuesday of each month at 5:00 p.m. at the Baker County Administration Office, Commission Chambers, 55 North Third Street, Macclenny, FL 32063. All agenda items should be submitted to County Administration via [sara.little@bakercountyfl.org](mailto:sara.little@bakercountyfl.org) and [kayla.riggs@bakercountyfl.org](mailto:kayla.riggs@bakercountyfl.org) no later than the Wednesday prior to the Commission meeting.

**Date of Submission:** 3/30/2026 **Meeting Date:** 4/7/2026

**Name of Submitter:** Lydia Mangano **Department:** SHIP

1. Nature and purpose of this agenda item:

LHAP (Local Housing Assistance Plan) updates (Disaster Strategy) page 15 per FHFC

2. Recommended Motion/Action:

Approve change and submission to FHFC

3. Will this item require a presentation? No. Documentation is included in agenda packet

4. Deadline for Completion: 4/7/2026

5. Fiscal Impact Questions:

Is this item included in the current budget? N/A

If item is grant related, is there a County match requirement? N/A

Explain the procurement process for this request (attach necessary documentation): N/A

**Local Government**

**SHIP LOCAL HOUSING ASSISTANCE PLAN (LHAP)**

**2026-2027, 2027-2028, 2028-2029**





**Table of Contents**

Description	Page #
<b>Section I, Program Details</b>	<b>3</b>
<b>Section II, Housing Strategies</b>	
A. Demolition / New Construction / Replacement	<b>8-10</b>
B. Rehabilitation	<b>11-12</b>
C. Emergency Assistance	<b>13-14</b>
D. Disaster Mitigation	<b>15-16</b>
<b>Section III, Incentive Strategies</b>	
A. Expedited Permitting	<b>17</b>
B. Ongoing Review Process	<b>17</b>
<b>Exhibits</b>	
A. Administrative Budget for each fiscal year covered in the Plan	
B. Timeline for Estimated Encumbrance and Expenditure	
C. Housing Delivery Goals Chart (HDGC) For Each Fiscal Year Covered in the plan	
D. Signed LHAP Certification	
E. Signed, dated, witnessed or attested adopting resolution	



**I. Program Details:**

**A. LG(s)**

Name of Local Government	BAKER COUNTY
Does this LHAP contain an interlocal agreement?	NO
If yes, name of other local government(s)	N/A

**B. Purpose of the program:**

- To meet the housing needs of the very low, low and moderate-income households;
- To expand production of and preserve affordable housing; and
- To further the housing element of the local government comprehensive plan specific to affordable housing.

**C. Fiscal years covered by the Plan: 2026-2027, 2027-2028, 2028-2029**

**D. Governance:** The SHIP Program is established in accordance with Section 420.907-9079, Florida Statutes and Chapter 67-37, Florida Administrative Code. Cities and Counties must be in compliance with these applicable statutes, rules and any additional requirements as established through the Legislative process.

**E. Local Housing Partnership:** The SHIP Program encourages building active partnerships between government, lending institutions, builders and developers, not-for-profit and community-based housing providers and service organizations, providers of professional services related to affordable housing, advocates for low-income persons, real estate professionals, persons or entities that can provide housing or support services and lead agencies of the local continuums of care.

**F. Leveraging:** The Plan is intended to increase the availability of affordable residential units by combining local resources and cost saving measures into a local housing partnership and using public and private funds to reduce the cost of housing. SHIP funds may be leveraged with or used to supplement other Florida Housing Finance Corporation programs and to provide local match to obtain federal housing grants or programs.

**G. Public Input:** Public input was solicited through face-to-face meetings with housing providers, social service providers and local lenders and neighborhood associations. Public input was solicited through the local newspaper in the advertising of the Local Housing Assistance Plan and the Notice of Funding Availability.

**H. Advertising and Outreach:** SHIP funding availability shall be advertised in a newspaper of general circulation and periodicals serving ethnic and diverse neighborhoods, at least 30 days before the beginning of the application period. If no funding is available due to a waiting list, no notice of funding availability is required.

**I. Waiting List/Priorities:** A waiting list will be established when there are eligible applicants for strategies that no longer have funding available. Those households on the waiting list will be notified of their status. Applicants will be maintained in an order that is consistent with the time completed applications were submitted as well as any established funding priorities as described in this plan.

The following priorities for funding described/listed here apply to all strategies and income categories unless otherwise stated in an individual strategy in Section II:



- Special Needs set-aside requirement
- Very low- and low-income level set-aside requirement
- Construction set-aside requirement

Applications are collected and reviewed as received. Applications that appear to meet unaccomplished required set-aside requirements are processed chronologically by applicant date for income qualification and become 'first qualified, first served'. If there is a waiting list and a person on the waiting list has not received any previous funding, that applicant/person will take precedence over an applicant that has received previous funding. After required set-aside requirements are accomplished, all other applications are processed for income qualification in like manner to above.

- J. Additional Help with SHIP available, except under conditions below:
- Applicant has reached the maximum award amount that was available in the LHAP strategy the year their original mortgage(s) were executed.
  - Applicant has unsatisfied mortgage(s) with Baker County.
  - Applicant failed to maintain insurance, property taxes were delinquent or received code infractions during previous mortgage term.

The only exceptions being, if a household member becomes disabled, and the home has to be modified for accessibility, or if disaster is declared for Baker County by either Florida Governor or President of the United States.

- K. **Discrimination:** In accordance with the provisions of ss.760.20-760.37, it is unlawful to discriminate on the basis of race, color, religion, sex, national origin, age, handicap, or marital status in the award application process for eligible housing.
- L. **Support Services and Counseling:** Support services and counseling services are available from various sources including in-person opportunities. Available support services may include but are not limited to: Homeownership Counseling (Pre and Post) and Credit Counseling. The County recommends and encourages these services; however, does not require these services in order to be financially assisted.

The County works with agencies to provide additional homeownership counseling services for assistance with clearance of deed issues such as Heirs' Property to remove barriers to housing assistance programs such as S.H.I.P. and or other assistance programs requiring proof of ownership (clear title/name on deed) in order to receive assistance.

- M. **Purchase Price Limits:** The sales price or value of new or existing eligible housing may not exceed 90% of the average area purchase price in the statistical area in which the eligible housing is located. Such average area purchase price may be that calculated for any 12-month period beginning not earlier than the fourth calendar year prior to the year in which the award occurs. The sales price of new and existing units, which can be lower but may not exceed 90% of the average area purchase price established by the U.S. Treasury Department or as described above.

The methodology used is:

U.S. Treasury Department	X
Local HFA Numbers	



- N. Income Limits, Rent Limits and Affordability:** The Income and Rent Limits used in the SHIP Program are updated annually by the Department of Housing and Urban Development and posted at [www.floridahousing.org](http://www.floridahousing.org).

*“Affordable” means that monthly rents or mortgage payments including taxes and insurance do not exceed 30 percent of that amount which represents the percentage of the median annual gross income for the households as indicated in Sections 420.9071, F.S. However, it is not the intent to limit an individual household’s ability to devote more than 30% of its income for housing, and housing for which a household devotes more than 30% of its income shall be deemed Affordable if the first institutional mortgage lender is satisfied that the household can afford mortgage payments in excess of the 30% benchmark and in the case of rental housing does not exceed those rental limits adjusted for bedroom size.*

- O. Administrative Budget:** A line-item budget is attached as Exhibit A. The city/county finds that the moneys deposited in the local housing assistance trust fund are necessary to administer and implement the local housing assistance plan.

**Section 420.9075 Florida Statute and Chapter 67-37, Florida Administrative Code, states:** “A county or an eligible municipality may not exceed the 5 percent limitation on administrative costs, unless its governing body finds, by resolution, that 5 percent of the local housing distribution plus 5 percent of program income is insufficient to adequately pay the necessary costs of administering the local housing assistance plan.”

**Section 420.9075 Florida Statute and Chapter 67-37, Florida Administrative Code, further states:** “The cost of administering the program may not exceed 10 percent of the local housing distribution plus 5 percent of program income deposited into the trust fund, except that small counties, as defined in s. 120.52(19), and eligible municipalities receiving a local housing distribution of up to \$350,000 may use up to 10 percent of program income for administrative costs.” The applicable local jurisdiction has adopted the above findings in the resolution attached as Exhibit E.

- P. Program Administration:** Administration of the local housing assistance plan will be performed by:

Entity	Duties	Admin. Fee Percentage
Local Government		10%
Third Party Entity/Sub-recipient		

- Q. Project Delivery Costs:** Project delivery costs may include any time spent by Housing Staff or County contracted third party consulting firm(s) who perform housing program tasks, including any and all activities associated with completed project delivery. These include but are not limited to: site surveys, title search, inspections, recording, engineering and will be included in the Deferred Payment Loan (DPL) Agreement also known as the mortgage. This will not exceed 2% of the award.
- R. Essential Service Personnel Definition (ESP):** ESP includes teachers and educators, other school district, community college, and university employees, all police, sheriff and fire personnel, health care personnel, EMT’s and first responders, skilled building trades and all members of the United States Armed Services regardless of status.



- S. Describe efforts to incorporate Green Building and Energy Saving products and processes:** Baker County encourages the incorporation of sustainable, storm-resistant innovative design and energy and water conservation into new construction and rehabilitation projects for ongoing sustainability and affordability. The County will, when economically feasible, employ the following Green Building requirements on new construction, rehabilitation, and emergency repair projects:
- Energy star rated windows, appliances, hot water heater, and ceiling fans.
  - Low flow plumbing fixtures.
  - Insulated exterior doors.
  - Increased insulation for walls and ceiling, minimum of R-38.
  - Higher efficiency HVAC units with programable thermostats. Minimum SEER ratings of 14.
- T. Describe efforts to meet the 20% Special Needs set-aside:** The Baker County SHIP Program coordinates advertising efforts with the Baker County Council on Aging and the ARC of North Florida to reach special needs applicants. The Baker County prioritization process prioritizes special needs applicants. Advertisements specify availability of funding for special needs applicants.
- U. Describe efforts to reduce homelessness:** Baker County is unique in that homelessness is not prevalent locally. The most common form of homelessness in Baker County is multiple family households in one dwelling. The program recognizes these types of situations when considering applications for home purchase and encourages the use of this program.
- V. General Provisions:** The following provisions will apply to all strategies unless otherwise indicated:
- 1) **Eligible Housing.** Any real, personal, homesteaded property located within Baker County which is designed and intended for the primary purpose of providing decent, safe, and sanitary residential units that are designed to meet the standards of the Florida Building Code or previous Building Codes adopted under Chapter 553. Manufactured housing (or mobile homes) must be no older than 2001 to be eligible for Rehabilitation or Emergency Repair. Manufactured housing is not eligible for Disaster Strategy.
  - 2) **Income Producing Properties.** Residential properties used as income producing properties are not eligible for any type of SHIP Assistance. Income producing properties are defined as properties producing rental income, or business income based on day care, personal services, retail services or similar activities that require regular and ongoing visits by clients and/or customers to the property. Home offices do not create income producing properties unless the office is regularly used to meet with customers within the property.
  - 3) **Lifetime Limit.** Applicants are eligible for assistance according to the schedule below and provisions listed in Section I item J above and cannot receive assistance twice in the same funding year:
    - a. Demolition/Replacement/New Construction – Once per lifetime plus once for emergency repair.
    - b. Owner Occupied Rehabilitation - Once per lifetime plus once for emergency repair.
    - c. Emergency Repair – Twice per lifetime.
  - 4) **SHIP Mortgage Position:** SHIP mortgages must be in primary position. SHIP mortgages may not be in positions inferior to primary position even in instances of subordination.
  - 5) **Applicants** may not have more than 1 active Deferred Payment Loan (DPL) agreement active at a time, except in the instance that one (1) is for Disaster Assistance.
  - 6) **Property** taxes and/or assessments must be current, must have clear title/deed, with no outstanding judgements, liens, orders, or encumbrances. This includes 1st or 2nd mortgages, Reverse mortgages and



Mortgage Recovery Advances.

- 7) **Any applicant** who is delinquent on child support, alimony or in violation of any valid court order or judgement will be denied SHIP assistance. If any person wishing to apply is awaiting trial/sentencing at time of application window and is only adult in the residence/home, applicant must wait until trial/sentence is completed and verdict handed down as applicants currently incarcerated are not eligible.
- 8) **Contractor Information.** For strategies requiring new construction and for any form of rehabilitation, repair, or reconstruction, only state licensed contractors with proof of active status and insurance will be approved for contract work.
- 9) Recipients of the SHIP Program are asked that all complaints and warranty issues be in writing and addressed to the Baker County Administration/SHIP Administrator and a copy addressed to the awarded contractor.
- 10) All requests for refinancing a SHIP deferred payment loan (DPL) shall be in writing addressed to the County Manager and Chairman of the Board. Information that must be included in your letter of request, name, date, address, date of SHIP DPL agreement, and reason for the request of refinancing. Final approval for all refinancing shall be the responsibility of the Board of County Commissioners. Additional information may be required.
- 11) If assistance is provided through the SHIP Program, subordination within the DPL term will be prohibited with the following exceptions:
  1. Refinancing for documented medical emergency, such as but not limited to heart attack, stroke, and automobile accident.
  2. Refinancing for documented major home repair/improvement, such as but not limited to persons with special needs, flooding, and fire.
  3. Refinancing for lower interest rate, with NO cash back to owner.
  4. Refinancing in the event of major loss of income from head of household.
  5. Refinancing in the event of the death of head of household



**Section II. LHAP Strategies:**

<b>A. Demolition/New Construction/Replacement</b>	Code 4
---------------------------------------------------	--------

a. Summary: Assistance will be provided on a one-time basis to homeowners whose homes are not in compliance with the State and local building codes or Section 8 Minimum Quality Standards. In lieu of rehabilitation when homes are deteriorated to the extent that repairs are beyond the allowable cost or 51% extensive structural damage, a replacement home will be constructed. The existing structure must be certified by the Baker County SHIP Administrator and the Baker County Building Official as substandard and not suitable for rehabilitation. Any site built or mobile home that is deemed beyond the cost of rehabilitation by the Baker County SHIP Administrator or Building Official must be demolished on site. The home must be owner occupied with a clear title.

- b. Fiscal Years Covered: 2026-2027, 2027-2028, 2028-2029
- c. Income Categories to be served: Extremely Low, Very Low and-, Low Income
- d. Maximum award: \$ 150,000
- e. Terms:
  - 1. Repayment loan/deferred loan/grant: Deferred loan secured by a note and mortgage
  - 2. Interest Rate: 0%
  - 3. Years in loan term: 20 years
  - 4. Forgiveness: The loan amount will be forgiven at a rate of one-twentieth (1/20) of the loan forgiven each year over the loan term as long as:
    - a. Property remains as principal, homesteaded, legal residence.
    - b. Property taxes are paid in full every year.
    - c. Owner maintains homeowner's insurance for full replacement value of property during the life of the loan with Baker County listed as mortgage holder.
    - d. No code enforcement violations exist.
  - 5. Repayment: None as long as in good standing.
  - 6. Default: The portion of the deferred payment loan remaining will be due at the occurrence of the earliest of one of the following events:
    - a. Death of recipient(s)
    - b. Sale or transfer of title
    - c. Property is no longer maintained as principal, homesteaded residence
    - d. Foreclosure or conveyance
    - e. Loss of homestead status
    - f. Tax Lien/Deed sale
  - 7. In the event of the death of the applicant(s) within the lien period, the loan may be assumed by a SHIP eligible, legal heir who will occupy the home as a primary homesteaded residence and have 180 days to income qualify. All heirs and successors will be held to the same rules and regulations, as did the applicant(s). The property may be sold; however, the lien shall be fully satisfied unless the new owner qualifies under the eligibility criteria of the program. If the legal heir is not SHIP eligible or chooses not to occupy the home, the outstanding balance of the loan will be due and payable.



- f. Recipient/Tenant Selection Criteria:
1. Applicants who have previously received SHIP assistance under this strategy are ineligible to apply.
  2. The property must be owner occupied.
  3. Applicants cannot possess more than \$50,000 in assets.
  4. The assessed value of an applicant's homestead property cannot exceed established purchase price limits as defined by Baker County's Local Housing Assistance Plan (LHAP) to receive assistance through the Baker County SHIP Program.
  5. Applicants must provide proof that property taxes are current.
  6. If new construction is replacing a mobile home, a copy of the title(s) in the applicant(s) name only must be provided.
  7. Deeds, warranty deeds, quit claim deeds, and indenture must be in applicant(s) name. Agreement for deeds, assumption agreements, rent to own agreements: private owner financing agreements will not be accepted. If both spouses are listed on the deed and one of the spouses are deceased, a copy of the death certificate is required.
- g. Additional Information:
1. Baker County shall be notified in writing two business days prior to demolition. The person or persons performing the demolition shall have Workers Compensation Insurance, Liability Insurance and a Baker County or City of Macclenny Occupational License. A copy of all three (3) such documents shall be included in a written notification provided to Baker County two business days prior to the demolition. It shall be the responsibility of the awarded contractor and/or their sub-contractors for the on-site demolition, the safe legal removal and appropriate disposal of the dilapidated structure. SHIP funds will be available for survey, title search, demolition, electric, water, sewer, septic hookups/installations and the construction of a new ready-to-move in structure.
  2. Recipients of SHIP program funding are asked that all complaints and warranty issues be submitted in writing and addressed to the Baker County Administration/Grants office and a copy addressed to the awarded contractor. This policy is in effect for the new construction/replacement and rehabilitation strategies.
  3. When the contractor has completed the home and is ready for the Certificate of Occupancy (CO), he will notify the Baker County Building Official (BCBO) requesting the required Certificate of Occupancy (CO) inspection. A date and time for the inspection shall be established. The building official will notify the grant administrator who in turn shall notify the homeowner of the date and time of the Certificate of Occupancy (CO) inspection.
  4. On the scheduled date and time of the Certificate of Occupancy (CO) inspection, the homeowner, grant administrator, contractor, and the building official or his licensed inspector shall inspect the home.
  5. The building official shall inspect the house for compliance with the current edition of the Florida Building Code.
  6. The grant administrator and homeowner shall inspect the home to ensure all issues and cosmetic issues have been satisfied.
  7. Should any item be found to be out of compliance by the building official, grant administrator, or homeowner, the contractor shall be required to correct said item. Should the item be code related a Certificate of Occupancy (CO) will not be issued per state law.



8. Should the item be cosmetic, the county shall withhold final payment to the contractor. Until all issues code and cosmetic have been completed, the Certificate of Occupancy (CO) will be issued and final payment to the contractor shall be made.
9. Should the homeowner have a complaint within one year (1) of the date of the Certificate of Occupancy (CO), the homeowner shall notify the administrator. The administrator shall notify the building official and a time shall be established for the administrator, and homeowner, and the building official (if applicable), now acting as a county employee, to inspect the home. After the home has been inspected, one of the following shall happen:
  - a. The complaint is justified as a valid complaint, and it is an item that should be corrected by the contractor. The contractor shall be notified and make said repairs.
    - i. After said repairs are completed, the contractor, homeowner, grant administrator, and building official/county employee shall inspect to ensure the item has been corrected.
    - ii. Should the contractor fail to repair the item; the contractor shall be taken off the list of contractors allowed to bid on future grant homes within Baker County.
  - b. If the complaint is found to be an invalid complaint by the grant administrator and building code administrator/county employee, no action will be required on the county contractor's part. The following is not all inclusive of invalid complaints:
    - i. Routine maintenance which the homeowner did not do, cleaning, painting, air filters for air conditioners, etc.
    - ii. Neglect on homeowners' part
    - iii. Abuse, removal of items
    - iv. Destruction of screens, screen doors, doors, broken windows, etc.



<b>B. Rehabilitation Program</b>	Code 3
----------------------------------	--------

a. Summary: SHIP financial assistance will be provided to complete the substantial rehabilitation of substandard, homeowner occupied housing, targeting health and safety concerns. For a mobile or manufactured home to qualify, property owner's name must be listed on title, it must match the name on the homesteaded property owned by the applicant and must have a manufacture date of 2001 or newer. In lieu of rehabilitation, when homes are deteriorated to the extent that repairs are beyond the allowable cost or 51% extensive structural damage, a replacement home will be constructed. The existing structure must be certified by the Baker County SHIP Administrator in consultation with the Baker County Building Official as substandard and not suitable for rehabilitation.

- b. Fiscal Years Covered: -2026-2027, 2027-2028, 2028-2029
- c. Income Categories to be served: Extremely Low, Very Low and, Low Income
- d. Maximum award:
  - 1. \$45,000 Extremely Low
  - 2. \$40,000 Very Low Income
  - 3. \$35,000 Low Income
- e. Terms:
  - 1. Repayment loan/deferred loan/grant: Deferred loan secured by a note and mortgage.
  - 2. Interest Rate: 0%
  - 3. Years in loan term: 15 years
  - 4. Forgiveness: The loan amount will be forgiven at a rate of one-fifteenth (1/15) of the loan forgiven each year over the loan term as long as:
    - a. Property is maintained as principal, homesteaded, legal residence.
    - b. Property taxes paid in full every year.
    - c. No code enforcement violations exist.
  - 5. Repayment: None as long as loan is in good standing.
  - 6. Default: The portion of the deferred payment loan remaining, will be due at the occurrence of the earliest of one of the following events:
    - a. Death of recipient(s)
    - b. Sale or transfer of title
    - c. Property is no longer maintained as principal, homesteaded residence
    - d. Foreclosure or conveyance
    - e. Loss of homestead status
    - f. Tax Lien/Deed sale
  - 7. In the event of the death of the applicant(s) within the lien period, the loan may be assumed by a SHIP eligible, legal heir who will occupy the home as a primary homesteaded residence and have 180 days to income qualify. All heirs and successors will be held to the same rules and regulations, as the applicant(s). The property may be sold; however, the lien shall be fully satisfied unless the new owner qualifies under the eligibility criteria of the program. If the legal heir is not SHIP eligible or chooses not to occupy the home, the outstanding balance of the loan will be due and payable.



- f. Recipient/Tenant Selection Criteria:
1. Applicants who have received prior SHIP assistance under this strategy are ineligible to apply.
  2. The property must be owner occupied.
  3. Applicants cannot possess more than \$50,000 in assets.
  4. The assessed value of an applicant's homestead property cannot exceed established purchase price limits as defined by Baker County's Local Housing Assistance Plan (LHAP) to receive assistance through the Baker County SHIP Program.
  5. Applicants must provide proof that property taxes are current.
  6. If new construction is replacing a mobile home, a copy of the title(s) in the applicant(s) name only must be provided.
  7. Deeds, warranty deeds, quit claim deeds, and indenture must be in applicant(s) name. Agreement for deeds, assumption agreements, rent to own agreements: private owner financing agreements will not be accepted. If both spouses are listed on the deed and one of the spouses are deceased, a copy of the death certificate is required.
- g. Additional Information:  
See above Section I, Program Details, item V. General Provisions for additional information.



<b>C. Emergency Repairs</b>	Code 6
-----------------------------	--------

A. Summary: SHIP funds will be used to provide emergency repair assistance to assist homeowners of site-built homes or eligible mobile homes (post 2001) to address emergency situations targeting health and safety concerns. The emergency repair work is defined as work that will address health and safety concerns to include but not be limited to:

1. Leaky Roof
2. Septic system work (repair/replace)
3. Well work (repair, replace)
4. HVAC work (repair, replace)
5. Wheelchair ramps
6. Other repairs decided on a case-by-case basis by the Baker County Board of Commissioners via recommendation of SHIP Administrator/Building Official.

- b. Fiscal Years Covered: -2026-2027, 2027-2028, 2028-2029
- c. Income Categories to be served: Very low, low and moderate
- d. Maximum award: \$ 20,000
- e. Terms:
  1. Repayment loan/deferred loan/grant: Deferred loan secured by a mortgage and note.
  2. Interest Rate: 0%
  3. Years in loan term: 5 years
  4. Forgiveness: The loan amount will be forgiven at a rate of one-fifth (1/5) of the loan forgiven each year over the loan term provided:
    - a. Property is maintained as principal, homesteaded, legal residence.
    - b. Property taxes paid in full every year.
    - c. No code enforcement violations exist.
  5. Repayment: None as long as loan is in good standing.
  6. Default: The portion of the deferred payment loan remaining, will be due at the occurrence of the earliest of one of the following events:
    - a. Death of recipient(s)
    - b. Sale or transfer of title
    - c. Property is no longer maintained as principal, homesteaded residence
    - d. Foreclosure or conveyance
    - e. Loss of homestead status
    - f. Tax Lien/Deed sale
  7. In the event of the death of the applicant(s) within the lien period, the loan may be assumed by a SHIP eligible, legal heir who will occupy the home as a primary homesteaded residence and have 180 days to income qualify. All heirs and successors will be held to the same rules and regulations, as did the applicant(s). The property may be sold; however, the lien shall be fully satisfied unless the new owner qualifies under the eligibility criteria of the program. If the legal heir is not SHIP eligible or chooses not



to occupy the home, the outstanding balance of the loan will be due and payable.

- f. Recipient/Tenant Selection Criteria: Applicants will be assisted on a first come, first qualified basis as described in Section II.
1. Applicants who have received prior SHIP assistance under this strategy are ineligible to apply.
  2. The property must be owner occupied.
  3. Applicants cannot possess more than \$50,000 in assets.
  4. The assessed value of an applicant's homestead property cannot exceed established purchase price limits as defined by Baker County's Local Housing Assistance Plan (LHAP) to receive assistance through the Baker County SHIP Program.
  5. Applicants must provide proof that property taxes are current.
  6. If new construction is replacing a mobile home, a copy of the title(s) in the applicant(s) name only must be provided.
  7. Deeds, warranty deeds, quit claim deeds, and indenture must be in applicant(s) name. Agreement for deeds, assumption agreements, rent to own agreements: private owner financing agreements will not be accepted. If both spouses are listed on the deed and one of the spouses are deceased, a copy of the death certificate is required.
- g. Additional Information:  
See above Section I, Program Details, item V. General Provisions for additional information.

<b>D. Disaster Mitigation</b>	Code 5, 16
-------------------------------	------------

a. Summary: The Disaster Strategy assists households following a disaster as declared by Executive Order of the Governor of the State of Florida or President of the United States. This strategy will only be implemented in the event of a disaster using any funds that have not yet been encumbered or additional disaster funds issued by Florida Housing Finance Corporation. SHIP disaster funds may be used for items such as, but not limited to:

1. Purchase of emergency supplies for eligible households to weatherproof damaged homes.
2. Interim repairs to avoid further damage; tree and debris removal required to make the individual housing unit habitual.
3. Construction of wells or repair of existing wells where public water is not available.
4. Payment of insurance deductibles for rehabilitation of homes covered under homeowners' insurance policies.
5. Security deposits and/or rental assistance for the duration of the State of Florida Executive order.
6. Other activities as proposed by the counties and eligible municipalities and approved by Florida Housing.

- b. Fiscal Years Covered: -2026-2027, 2027-2028, 2028-2029
- c. Income Categories to be served: Extremely Low, Very Low and Low Income
- d. Maximum award: \$ 10,000
- e. Terms:
  1. Repayment loan/deferred loan/grant: Deferred loan secured by a note and mortgage. **Rental assistance will be awarded as a grant.** (THIS LINE ADDED BY FHFC REVIEW COMMITTEE REP)
  2. Interest Rate: 0%
  3. Years in loan term: 5 years
  4. Forgiveness: The loan will be forgiven at a rate of one-fifth (1/5) of the loan forgiven each year over the loan term provided:
    - a. Property is maintained as principal, homesteaded, legal residence.
    - b. Property taxes paid in full every year.
    - c. No code enforcement violations exist.
  5. Repayment: None as long as in good standing.
  6. Default: The portion of the deferred payment loan remaining, will be due at the occurrence of the earliest of one of the following events:
    - a. Death of recipient(s)
    - b. Sale or transfer of title
    - c. Property is no longer maintained as principal, homesteaded residence
    - d. Foreclosure or conveyance
    - e. Loss of homestead status
    - f. Tax Lien/Deed sale
  7. In the event of the death of the applicant(s) within the lien period, the loan may be assumed by a SHIP



eligible, legal heir who will occupy the home as a primary homesteaded residence and have 180 days to income qualify. All heirs and successors will be held to the same rules and regulations, as did the applicant(s). The property may be sold; however, the lien shall be fully satisfied unless the new owner qualifies under the eligibility criteria of the program. If the legal heir is not SHIP eligible or chooses not to occupy the home, the outstanding balance of the loan will be due and payable.

- f. Recipient/Tenant Selection Criteria: Applicants will be assisted on a first come, first qualified basis as described in Section II.
1. Property must be owner occupied.
  2. Applicants will be assisted on a first-come, first-qualified, first-ready basis. Priority will be given to the elderly (persons over the age of 62) and persons with special needs as defined in 420.0004 (13), F. S..
  3. Applicants cannot possess more than \$50,000 in assets.
  4. The assessed value of an applicant's homestead property cannot exceed established purchase price limits as defined by Baker County's Local Housing Assistance Plan (LHAP) to receive assistance through the Baker County SHIP Program.
  5. Applicants must provide proof that property taxes are current.
  6. Deeds, warranty deeds, quit claim deeds, and indenture must be in applicant(s) name. Agreement for deeds, assumption agreements, rent to own agreements: private owner financing agreements will not be accepted. If both spouses are listed on the deed and one of the spouses are deceased, a copy of the death certificate is required.
- g. Additional Information:
1. Funds for disaster mitigation will only be allocated from unencumbered funds or additional funds awarded through Florida Housing Finance Corporation for the disaster. Mobile homes built/manufactured prior to 2001 are not eligible.
  2. Applicant(s) must own and occupy the home and have damage directly caused from the disaster as certified by the Baker County Emergency Management Director and/or the Baker County Building Official.
  3. Applicant(s) must either have NO homeowners' insurance (and/or flood insurance if in a flood zone) OR if they do have insurance, the damage to be repaired is not covered under their insurance policy (documentation required including policy information included on application).
  4. Existing homeowners' and/or flood insurance not required to be eligible for assistance under this strategy.
    - a. Refinancing for documented medical emergency, such as but not limited to these listed only, heart-attack, stroke, automobile accidents. All incidents will be approved or disapproved by the Baker County Board of Commissioners.
    - b. Refinancing for documented major home repair/improvement, such as but not limited to these listed only, storm damage, person with special needs, flooding due to storm or broken pipe.
  5. Refinancing for lower interest rate, with NO cash back to owner.
  6. Refinancing in the event of major loss of income from head of household.
  7. Refinancing in the event of the death of head of household



### III. LHAP Incentive Strategies

In addition to the **required Incentive Strategy A and Strategy B**, include all adopted incentives with the policies and procedures used for implementation as provided in Section 420.9076, F.S.:

- A. Name of the Strategy: **Expedited Permitting**  
Permits as defined in s. 163.3177 (6) (f) (3) for affordable housing projects are expedited to a greater degree than other projects. When contractors apply for a permit for a SHIP related project, the review and processing of that permit is given priority over other permits. It is moved to the front of the line and processed first.
  
- B. Name of the Strategy: **Ongoing Review Process**  
An ongoing process for review of local policies, ordinances, regulations and plan provisions that increase the cost of housing prior to their adoption.

### IV. EXHIBITS:

#### Required

- A. Administrative Budget for each fiscal year covered in the Plan.
- B. Timeline for Estimated Encumbrance and Expenditure.
- C. Housing Delivery Goals Chart (HDGC) For Each Fiscal Year Covered in the plan.
- D. Signed LHAP Certification.
- E. Signed, dated, witnessed or attested adopting resolution.



## BAKER COUNTY BOARD OF COUNTY COMMISSIONERS

### AGENDA ITEM REQUEST FORM

The Board of County Commissioners meet on the 1<sup>st</sup> and 3<sup>rd</sup> Tuesday of each month at 5:00 p.m. at the Baker County Administration Office, Commission Chambers, 55 North Third Street, Macclenny, FL 32063. All agenda items should be submitted to County Administration via [sara.little@bakercountyfl.org](mailto:sara.little@bakercountyfl.org) and [kayla.riggs@bakercountyfl.org](mailto:kayla.riggs@bakercountyfl.org) no later than the Wednesday prior to the Commission meeting.

**Date of Submission:** 3/30/2026 **Meeting Date:** 4/7/2026

**Name of Submitter:** Chris Lee **Department:** Public Works

1. Nature and purpose of this agenda item:  
The county sought bids for the construction of project 2025-16, for CR 229 N paving from Verdie Dorman to 3.9 miles north of Verdie Dorman  
two responses were received Preferred Materials in the amount of \$2,584,046.75, and  
Anderson Columbia in the amount of, \$3,459,381.67.

2. Recommended Motion/Action:  
Award of contract to lowest bid, Preferred Materials in the amount of \$2,584,046.75.

3. Will this item require a presentation? no, item backup documentation only.

4. Deadline for Completion: n/a

5. Fiscal Impact Questions:  
Is this item included in the current budget? no, FDOT grant

If item is grant related, is there a County match requirement? no

Explain the procurement process for this request (attach necessary documentation): Bid solicitation posted to DemandStar, County website and in The Baker County Press.





## BAKER COUNTY BOARD OF COUNTY COMMISSIONERS AGENDA ITEM REQUEST FORM

The Board of County Commissioners meet on the 1<sup>st</sup> and 3<sup>rd</sup> Tuesday of each month at 5:00 p.m. at the Baker County Administration Office, Commission Chambers, 55 North Third Street, Macclenny, FL 32063. All agenda items should be submitted to County Administration via [sara.little@bakercountyfl.org](mailto:sara.little@bakercountyfl.org) and [kayla.riggs@bakercountyfl.org](mailto:kayla.riggs@bakercountyfl.org) no later than the Wednesday prior to the Commission meeting.

**Date of Submission:** 3/30/2026 **Meeting Date:** 4/7/2026

**Name of Submitter:** Chris Lee **Department:** Public Works

1. Nature and purpose of this agenda item:  
Award of CEI contract for CR 229 N paving from Verdie Dorman to 3.9 miles north of Verdie Dorman to Locklear and Associates in the amount of \$129,000.00. Proposal attached.

2. Recommended Motion/Action:  
Award of contract

3. Will this item require a presentation? no, item backup documentation only.

4. Deadline for Completion: n/a

5. Fiscal Impact Questions:

Is this item included in the current budget? no, FDOT grant

If item is grant related, is there a County match requirement? no

Explain the procurement process for this request (attach necessary documentation): Picked CEI from County's approved list of engineering companies

# LOCKLEAR

February 24, 2026

Mr. Chris Lee, Public Works Director  
Baker County  
8156 Cypress Street  
Sanderson, FL 32087

RE: Proposal to Provide Construction Engineering Inspection Services  
County Road 229N Resurfacing

Dear Mr. Lee:

Locklear & Associates, Inc. (Locklear) is pleased to present this proposal for professional services to Baker County (County). This proposal describes the professional construction engineering inspection (CEI) services to be provided by Locklear during the resurfacing of County Road 229N in accordance with the County's agreement (FDOT #445819-1) with the Florida Department of Transportation (hereinafter "Project").

## Scope of Services

The Project includes improvements to approximately 3.9 miles of County Road 229 North beginning at Verdie Dorman Road. Construction will be done in accordance with the permitted design plans prepared by the design engineer.

Locklear will provide construction engineering inspection services in accordance with the scope of work defined in the County's agreement with the Florida Department of Transportation. The services will include the following:

- Schedule a pre-construction meeting with the contractor to review construction issues and schedule.
- Review and comment on the contractor's schedule.
- Provide full-time construction inspection in accordance with the County's grant agreement.
- Document and route contractor's requests for clarifications and change orders to the project engineer.
- Review requisitions and recommend payment with concurrence from the project engineer.
- Notify project engineer and County of deviations from the design and specifications by the contractor.
- Prepare punch list.
- Review contractor's notice of completion.
- Review and comment on contractor's as-built drawings.
- Recommend close-out payment.
- Provide certification of completion to the County.

# LOCKLEAR

## Fee

The scope of services described herein will be completed for a lump sum fee of \$129,000. Locklear will provide monthly invoices of equal amounts to be determined by the length of the contractor's schedule.

We appreciate the opportunity to be of service to you and the citizens of Baker County. If you have any questions, please call me or Lisa Baker at 352-672-6867.

Sincerely,

A handwritten signature in black ink, appearing to read "John Locklear". The signature is fluid and cursive, with a long horizontal stroke extending to the right.

John Locklear, P.G.  
Owner/President  
Locklear & Associates, Inc.



**RESOLUTION 2026-14**

**A RESOLUTION OF THE BOARD OF COUNTY COMMISSIONERS OF BAKER COUNTY, FLORIDA AUTHORIZING THE EXECUTION OF THE TRAFFIC SIGNAL MAINTENANCE AND COMPENSATION AGREEMENT WITH FLORIDA DEPARTMENT OF TRANSPORTATION FINANCIAL PROJECT #41351818805.**

**WHEREAS**, the Florida Department of Transportation desires the execution of the Traffic Signal Maintenance and Compensation Agreement for US 90 at Enterprise East Blvd., US 90 at C-229/127, US 90 at C-231/Pine St., US 90 at Wildcat Ave., US 90 at CR125, and SR121 at Cr 23C Steel Bridge Road.

**NOW, THEREFORE, BE IT RESOLVED** this 7<sup>th</sup> day of April 2026, by the Board of County Commissioners of Baker County, Florida, that the County Manager of the Board of County Commissioners is hereby authorized to execute the Supplemental Funding Agreement between the Baker County Board of Commissioners and the Florida Department of Transportation for Financial Project ID: 41351818805.

**BOARD OF COUNTY COMMISSIONERS  
OF BAKER COUNTY, FLORIDA**

---

**Ronald Mann, Chairman**

**ATTEST:**

---

**Stacie D. Harvey, Clerk**

STATE OF FLORIDA DEPARTMENT OF TRANSPORTATION  
**TRAFFIC SIGNAL MAINTENANCE AND COMPENSATION AGREEMENT**

**EXHIBIT A**  
**Reimbursement for Maintenance and Operation FY 2027**

BAKER COUNTY																		
Intersection Location	Traffic Signals (TS)	Traffic Signal - Interconnected & monitored (IMTS)	Intersection Control Beacon (ICB)	Pedestrian Flashing Beacon (PFB)	Emergency Fire Dept. Signal (FDS)	Speed Activated Warning Display (SAWD)	Illuminated Street Name Signs (ISNS)	Blank Out Sign (BOS)	Traffic Warning Beacon (TWB)	Probe Data Detection System (PDDS)	Uninterruptible Power Supplies (UPS)	Connected Automated Vehicle Devices (CAVD)	Pedestrian Hybrid Beacon (PHB)	Arterial Dynamic Message Sign (ADMS)	Passive Pedestrian Detection (PPD)	Traffic Monitoring Camera (TrMC)	In-Roadway Warning Lights (IRWL)	Compensation Amount (using Unit Rates from Exhibit B)
SR10, (US90) at ENTERPRISE EAST BLVD. (WALMART DIST CTR)			\$1,035															\$1,035
SR10, (US90) at C-229/127			\$1,035															\$1,035
SR10, (US90) at C-231/PINE ST.			\$1,035															\$1,035
SR10, (US90) at WILDCAT AVE.	\$4,266																	\$4,266
SR10, (US90) at CR125, (GLEN AVE.)	\$4,266																	\$4,266
SR121 at CR 23C STEEL BRIDGE ROAD			\$1,035															\$1,035
<b>Total Lump Sum Amount*</b>																	<b>\$12,672.00</b>	

\* Amount paid shall be the Total Lump Sum (minus any retainage or forfeiture).

I certify that the above Traffic Signals and Devices will be maintained and operated in accordance with the requirements of the Traffic Signal Maintenance and Compensation Agreement. For satisfactory completion of all services detailed in this Agreement for this time period, the Department will pay the Maintaining Agency a Total Lump Sum (minus any retainage or forfeiture) of \$12,672.00

\_\_\_\_\_  
 Maintaining Agency

\_\_\_\_\_  
 Date

\_\_\_\_\_  
 District Traffic Operations Engineer

\_\_\_\_\_  
 Date

STATE OF FLORIDA DEPARTMENT OF TRANSPORTATION  
**AMENDMENT TO THE TRAFFIC SIGNAL MAINTENANCE  
AND COMPENSATION AGREEMENT**

CONTRACT NO. ARV13  
FINANCIAL PROJECT NO. 41351818805  
F.E.I.D. NO. F596000508007  
AMENDMENT NO. \_\_\_\_\_

**THIS AMENDMENT TO THE TRAFFIC SIGNAL AND MAINTENANCE AGREEMENT** ("Amendment") is made and entered into on this \_\_\_\_\_ day of \_\_\_\_\_, by and between the STATE OF FLORIDA, DEPARTMENT OF TRANSPORTATION ("Department"), an agency of the State of Florida, and Baker County, ("Maintaining Agency").

**RECITALS**

WHEREAS, the Department and the Maintaining Agency on \_\_\_\_\_ entered into a Traffic Signal Maintenance and Compensation Agreement ("Agreement").

WHEREAS, the Parties have agreed to modify the Agreement on the terms and conditions set forth herein.

NOW THEREFORE, in consideration of the mutual covenants in this Amendment, the Agreement is amended as follows:

1. Exhibit A is amended, superseded and replaced in its entirety with the new Exhibit A that is attached to this Amendment.

IN WITNESS WHEREOF, the undersigned parties have executed this Amendment on the day, month and year set forth above.

Baker County, Florida  
(Maintaining Agency)

By: \_\_\_\_\_  
(Authorized Signature)

Print/Type Name: \_\_\_\_\_

Title: \_\_\_\_\_

**STATE OF FLORIDA  
DEPARTMENT OF TRANSPORTATION**

By: \_\_\_\_\_  
(Authorized Signature)

Print/Type Name: James Hannigan

Title: District Traffic Operations Engineer

Legal Review: \_\_\_\_\_



**BAKER COUNTY BOARD OF COUNTY COMMISSIONERS**  
**AGENDA ITEM REQUEST FORM**

The Board of County Commissioners meet on the 1<sup>st</sup> and 3<sup>rd</sup> Tuesday of each month at 5:00 p.m. at the Baker County Administration Office, Commission Chambers, 55 North Third Street, Macclenny, FL 32063. All agenda items should be submitted to County Administration via [sara.little@bakercountyfl.org](mailto:sara.little@bakercountyfl.org) and [kayla.riggs@bakercountyfl.org](mailto:kayla.riggs@bakercountyfl.org) no later than the Wednesday prior to the Commission meeting.

**Date of Submission:** April 2, 2026 **Meeting Date:** April 7, 2026

**Name of Submitter:** Sara Little **Department:** Administration

1. Nature and purpose of this agenda item:  
Approval of Opposition Letter for the Water First North Florida project. This project involves piping highly treated wastewater from Duval County west toward the Suwannee River basin. Daily amounts are estimated to be 40million gallons of reclaimed water. While a site has not been selected, the intent is that it would be somewhere in the Suwannee River Basin.

2. Recommended Motion/Action:  
Approve the opposition letter as submitted.

3. Will this item require a presentation? No

4. Deadline for Completion: ASAP

5. Fiscal Impact Questions:

Is this item included in the current budget? NA

If item is grant related, is there a County match requirement? NA

Explain the procurement process for this request (attach necessary documentation): NA



**SARA LITTLE**  
COUNTY MANAGER

# *Baker County* *Board of Commissioners*

55 NORTH THIRD STREET  
MACCLENNY, FLORIDA 32063  
(904) 259-3613 • (904) 259-7610  
[www.bakercountyfl.org](http://www.bakercountyfl.org)



**RONALD MANN**  
CHAIRMAN

April 7, 2026

Ms. Virginia Johns, Chair  
Suwannee River Water Management District  
9225 CR 49  
Live Oak, Florida 32060

Re: Opposition to the Water First North Florida Project

Dear Ms. Johns:

The Baker County Board of County Commissioners respectfully writes to formally oppose the proposed Water First North Florida Project. On behalf of our residents, we have significant concerns regarding the potential adverse environmental, public health, and economic impacts associated with this project.

While we recognize the importance of ensuring sustainable water resources for North Florida, the proposed approach raises substantial concerns. The plan to transfer large volumes of treated wastewater into the Floridan Aquifer introduces uncertainty regarding long-term negative impacts. As demonstrated through similar concerns raised by neighboring counties, the scale and methodology of this project differ significantly from prior efforts and have not been sufficiently proven safe for our region.

Additionally, the proposal to transport this water over long distances through extensive pipeline infrastructure introduces further risk. A failure, leak, or rupture at any point along the system could result in the catastrophic uncontrolled release of wastewater into surrounding lands, wetlands, or waterways. Such an event would have immediate and lasting environmental consequences and pose devastating risks to nearby communities. Given the length and complexity of the proposed conveyance system, the potential for mechanical failure or unforeseen incidents cannot be ignored.

Our primary concerns include:

## **1. Environmental Impact**

The springs, rivers, and aquifer systems that support Baker County are already under stress. Introducing treated wastewater at the proposed scale could result in unintended and potentially

**RONALD MANN**  
DISTRICT 1

**JIMMY ANDERSON**  
DISTRICT 2

**TYLER MOBLEY**  
DISTRICT 3

**BLAKE IVERSON**  
DISTRICT 4

**MARK HARTLEY**  
DISTRICT 5

irreversible negative ecological consequences. Additional clarity is needed regarding contaminant removal and long-term monitoring.

## **2. Public Health and Water Security**

Residents rely heavily on clean groundwater for drinking water. There remains uncertainty about the safety and reliability of even treated wastewater entering the aquifer, and insufficient assurance has been provided to guarantee protection of public health.

## **3. Economic Consequences**

Baker County's economy depends on agriculture, natural resources, and outdoor recreation. Any degradation of water quality will negatively impact these sectors and impose long-term financial burdens on our community.

## **4. Uncertain Risk vs. Local Benefit**

Current information does not clearly demonstrate a direct benefit to Baker County that would justify the potential risks.

Once implemented, the consequences of this project may not be easily reversed. Given the magnitude of uncertainty, including the risks associated with long-distance transport infrastructure, and the potential for widespread impact, we believe it is not prudent to proceed with the project in its current form.

For these reasons, the Baker County Board of County Commissioners strongly opposes the Water First North Florida Project. We respectfully urge the Suwannee River Water Management District and all relevant agencies to reconsider this proposal and pursue alternative solutions that prioritize the long-term protection of our water resources and communities.

Sincerely,

Ronald Mann, Chair  
District 1, County Commissioner

Oliver J. Anderson  
District 2

Tyler Mobley  
District 3

Blake Iverson  
District 4

Mark Hartley  
District 5



# BAKER COUNTY TOW RATE ANALYSIS

## Duval (Current Baker) vs. Putnam & Recommendations

Baker County Administration was approached by local tow operators regarding non-consensual (Sheriff's Office Rotation Calls) tow rates. Currently, Baker County does not have its' own tow rate schedule. The rates used for Baker County following Florida Statutes by using the nearest County with established rates. In such, Baker County uses rates issued by Duval County. These rates are adjusted annually and typically see a 3% average increase. County Administration staff have researched Duval (Current Baker Rates) and Putnam County rates in efforts to establish rates specifically for Baker County.

Baker County should establish its own maximum towing rates, using Duval County's current schedule as the baseline because that is the schedule Baker currently follows in practice, but adjusting the rates moderately to reflect Baker County's larger geography and longer average tow distances. The County should increase mileage and certain related charges modestly, while keeping the base tow fee, storage, and after-hours fees below or near surrounding county increases where necessary.

Upon review of this information, staff recommends the following:

# BAKER COUNTY TOW RATE ANALYSIS

## Duval (Current Baker) vs. Putnam & Recommendations

---

### CLASS A (Light Duty)

<u>Category</u>	<u>Duval</u>	<u>Putnam</u>	<u>Recommendation</u>
Hook Fee	\$146.52	\$175.00	\$160.00
Mileage	\$4.20	\$6.00	\$5.00
Hourly	\$125.58	\$175.00	\$140.00
Storage (Out)	\$31.40	\$45.00	\$35.00
Storage (In)	\$37.80	\$55.00	\$42.00
Admin Fee	\$87.28	~\$225	\$100 cap
After Hours	\$79.12	\$100.00	\$90.00

### CLASS B (Medium Duty)

<u>Category</u>	<u>Duval</u>	<u>Putnam</u>	<u>Recommendation</u>
Hook Fee	\$265	\$350	\$300
Mileage	\$4.50	\$6.00	\$5.25
Hourly	\$180	\$350	\$250
Storage	\$50	\$65	\$55

### CLASS C (Heavy Duty)

<u>Category</u>	<u>Duval</u>	<u>Putnam</u>	<u>Recommendation</u>
Hook Fee	\$385	\$600	\$475
Mileage	\$5.00	\$7.00	\$6.00
Hourly	\$275	\$500	\$375
Storage	\$65	\$85	\$70



## BAKER COUNTY BOARD OF COUNTY COMMISSIONERS

### AGENDA ITEM REQUEST FORM

The Board of County Commissioners meet on the 1<sup>st</sup> and 3<sup>rd</sup> Tuesday of each month at 5:00 p.m. at the Baker County Administration Office, Commission Chambers, 55 North Third Street, Macclenny, FL 32063. All agenda items should be submitted to County Administration via [sara.little@bakercountyfl.org](mailto:sara.little@bakercountyfl.org) and [kayla.riggs@bakercountyfl.org](mailto:kayla.riggs@bakercountyfl.org) no later than the Wednesday prior to the Commission meeting.

**Date of Submission:** March 30, 2026 **Meeting Date:** April 7, 2026

**Name of Submitter:** Kayla Riggs **Department:** Shoals Park

1. Nature and purpose of this agenda item:  
approval of park equipment for Shoals Park. Staff sought quotes per purchasing policy for Shoals Park equipment ground cover, borders, etc. BYO quoted us, \$38,708.00, for park equipment, swing set, ground cover, and installation. BYO is under FL marketplace vendor number: 30105262 so only one quote was needed.

2. Recommended Motion/Action:  
approval of purchase for shoals park playground.

3. Will this item require a presentation? No, Item backup document only.

4. Deadline for Completion: before end of fiscal year.

5. Fiscal Impact Questions:

Is this item included in the current budget? during the FY25/26 budget hearing BOCC approved \$40,000.00 for shoals park playground and installation.

If item is grant related, is there a County match requirement? na

Explain the procurement process for this request (attach necessary documentation): staff sought quotes and make a recommendation to BOCC. BOCC approves.



# Proposal



## Let's Make Smiles Complete

Bringing Play to Your Community.  
Safe, Fun & Affordable!

### Baker County - Shoals Park Solar Flare Proposal

Item	Price
 EQUIPMENT	\$ 25,460.00
<b>NPC</b> INSTALLATION	\$ 13,248.00
<b>TURNKEY TOTAL</b>	<b>\$ 38,708.00</b>

DETAILS | TERMS | CONDITIONS:

NOTE: SEE PROPOSAL FOR DETAILED BREAKDOWN.

Solar Flare option - includes swing set.

Delivering More  
**Play, Smiles  
Fun & Value**  
for Kids – *Since 1999!*

Copyright © 1999-2025 BYO Recreation.  
All Rights Reserved

[www.byoplayground.com](http://www.byoplayground.com)

## Contact your Playologist!

Devon Ward | (904) 604-7872 | [devon.ward@byoplayground.com](mailto:devon.ward@byoplayground.com)

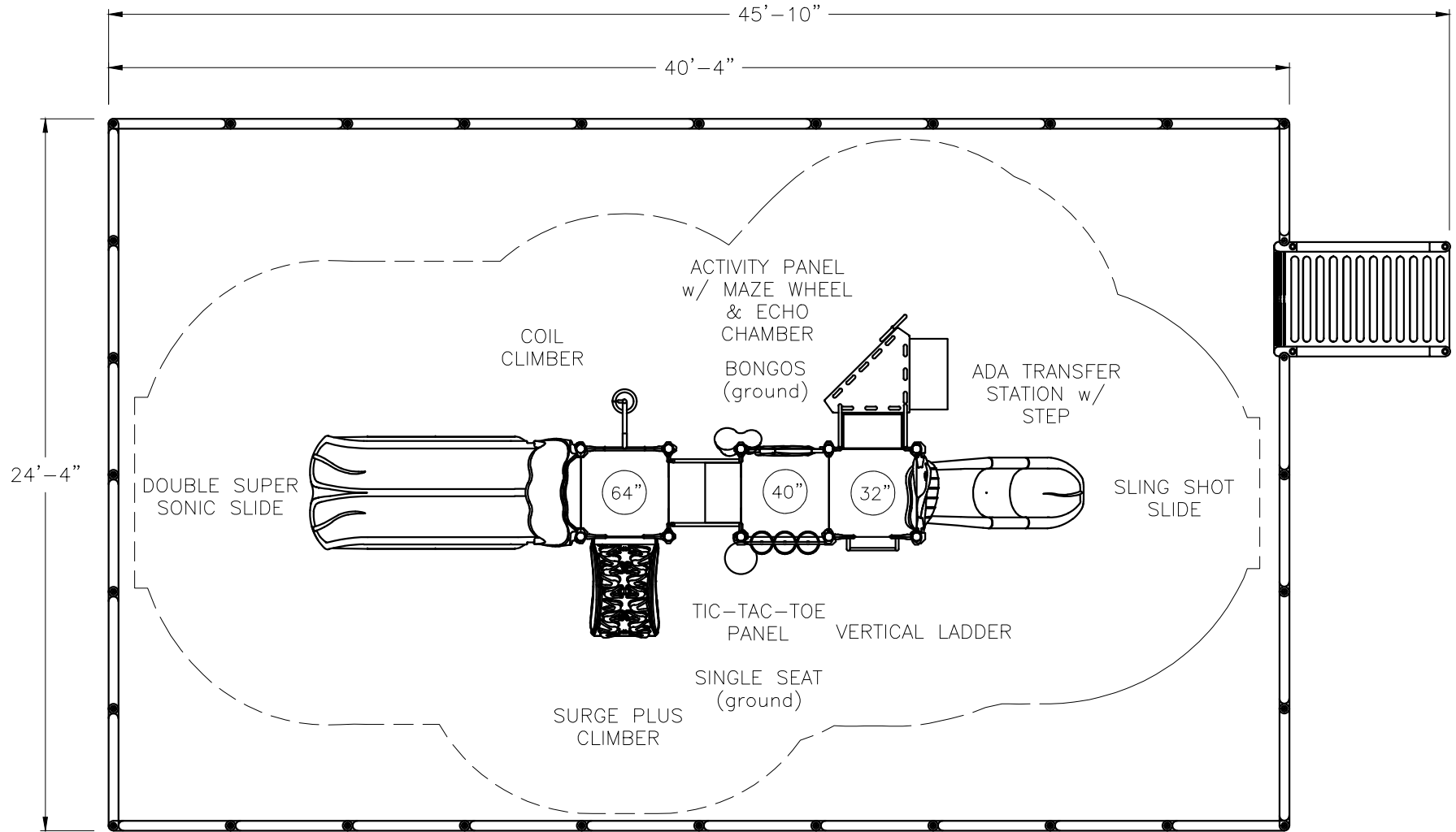

**Solar Flare**  
Structure 5653-PP

Signature: \_\_\_\_\_

Equipment Age Range: 2-5 or 5-12  
 Critical Fall Height: 64"  
 User Capacity: 30-35  
 Total Play Components: 9  
 Total Accessible Components: 9

	The above layout:
✓	COMPLIES TO ASTM
✓	COMPLIES TO CPSC
✓	COMPLIES TO ADA

Space Required: 24'-4" x 45'-10"  
 Surfacing Area: 939 s.f.  
 Surfacing Material: EWF  
 Surfacing Depth Required: 12"  
 Border Info: 31 & 1 ADA Ramp

Drawn By: S. Nance  
 Date: 1/23/2019  
 Revision:  
 Scale: 3/16" = 1'-0"  
 Drawing scaling possible only  
 when in 8.5" x 11" format





**Solar Flare** - Springtime Colors  
Structure 5653-PP

Signature: \_\_\_\_\_

Note: Colors above are for representational purposes only. Actual colors may vary slightly.

Posts, Double Super Sonic Slide: Green • Metals, Single Seat, Activity Panel: Beige • Decks: Brown • Surge Climber, Bongos: Spring Green • Sling Shot Slide: Green, Spring Green & Beige



[www.BYOPlayground.com](http://www.BYOPlayground.com)



## Solar Flare - Springtime Colors

Structure 5653-PP

Signature: \_\_\_\_\_

Note: Colors above are for representational purposes only. Actual colors may vary slightly.

Posts, Double Super Sonic Slide: Green • Metals, Single Seat, Activity Panel: Beige • Decks: Brown • Surge Climber, Bongos: Spring Green • Sling Shot Slide: Green, Spring Green & Beige



[www.BYOPlayground.com](http://www.BYOPlayground.com)



Beyond  
Your  
Ordinary

# PROPOSAL #: 120820

**ACCOUNT:**  
BAKER COUNTY RECREATION DEPARTMENT

**DATE CREATED:**  
3/30/2026

**ACCOUNT REP:**  
Devon Ward

## PREPARED FOR:

**PRIMARY CONTACT:**  
Kayla Riggs

**EMAIL:**  
kayla.riggs@bakercountyfl.org

**PHONE NUMBER:**  
+19042593613x1

**ORGANIZATION:**  
Baker County Recreation  
Department



## BILLING & SHIPPING:



**BILLING ADDRESS:**  
Baker County Recreation  
Department  
490 North Blvd W  
Macclenny, FL 32063

**SHIPPING ADDRESS:**  
Baker County Recreation  
Department  
9316 Odis Yarborough Road  
Glen St. Mary, FL 32063

*Correct?*

Qty	Product	Price	Discount	Total
1	 <p><b>SOLAR FLARE - QUICK SHIP</b> Model: 5653-PP-QS Color Options: Springtime Solar Flare is a sprawling play structure that offers a fun and challenging play experience for invigorating recess!</p> <p>Sliding Activities (2):</p> <ul style="list-style-type: none"> <li>Double Super Sonic Slide</li> <li>Sling Shot Slide</li> </ul> <p>Climbing Activities (3):</p> <ul style="list-style-type: none"> <li>Coil Climber</li> <li>Vertical Ladder Climber</li> <li>Surge Plus Climber</li> </ul> <p>Dramatic &amp; Sensory Play (4):</p> <ul style="list-style-type: none"> <li>Tic-Tac-Toe Panel</li> <li>Single Seat</li> <li>Bongos</li> <li>Activity Panel w/ Maze Wheel &amp; Echo Chamber</li> </ul> <p>Solar Flare features:</p> <ul style="list-style-type: none"> <li>- Commercial grade components specifically engineered to resist corrosion, fading and mildew.</li> <li>- Designed in compliance with public playground safety</li> </ul>	\$52,573.00	\$36,149.00	\$16,424.00

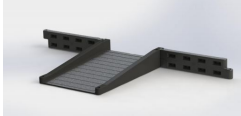
		<p>- Meets ADA guidelines and allow inclusive play for all children.</p> <p>- Available in Two Color Options</p>			
1		<p><b>SINGLE BAY BIPOD SWING SET W/2 STRAP SEATS - GREEN YOKES</b>                      Model: 7007-UP                      The Bipod Swings feature a 8' high frame with 2-3/8" galvanized pipe top rail and 2-3/8" diameter legs. Choose from Powder coated blue (BLU) or green (GRN) yoke connectors.                      Choose from Straps or Tot Seats (or a combination of both if a Two Bay) both include the necessary swing hangers, chain and factory-closed S-hooks.</p> <p>Use Zone Information:</p> <p>One Bay w/ Strap Seats: 25' x 32'</p> <p>One Bay w/ Tot Seats: 25' x 24'</p> <p>Two Bay w/ 4 Strap Seats: 37' x 32'</p> <p>Two Bay w/ 2 Strap Seat &amp; 2 Tot Seats: 37' x 32'</p> <p>Two Bay w/ 4 Tot Seats: 37' x 24'</p> <p>Warranty Information:</p> <p>5 Year Warranty on Metal Parts &amp; Ground Mount Metals Parts.</p> <p>10 Year Warranty on Upright Posts</p>	\$1,755.00	\$0.00	\$1,755.00
1		<p><b>WOOD PLAYGROUND MULCH</b>                      Model: BYO-510Z                      IPEMA certified to meet ASTM, CPSC, and ADA playground surfacing standards. Engineered wood fiber (EWF) playground safety surfacing is manufactured from natural fibers, and is designed to reduce injuries on playgrounds, and provide a stable, resilient surface for trails. It is a 100% natural product and contains no chemicals or artificial ingredients. Fresh wood is utilized than cannot be made into lumber. Environmentally safe. Meets non-flammability standards.</p>	\$4,136.00	\$0.00	\$4,136.00
77 CY FOR A 12" FINISHED DEPTH					
2		<p><b>DURALINER</b>                      Model: duraliner                      1,500 square feet per roll</p>	\$298.00	\$0.00	\$596.00
43		<p><b>PLAYGROUND BORDER WITH SURFACING GUIDE</b>                      Model: APS-2003                      Playground Border with Surfacing Guide - 4ft x 12in - Black</p>	\$43.00	\$0.00	\$1,849.00

		<p>ers surround your playground area with a no-maintenance alternative to wood and help keep playground surfacing in place. They feature a newer, more symmetrical design on the front and a surfacing guide on the middle of the back. The guides mark at 1" - 7" on the 8" borders and at 1" - 11" on the 12" borders, which allows you to easily inspect your surfacing depth and ensure adequate surfacing. Made from 100% plastic. Includes spike.</p>			
1		<p><b>ADA / WHEELCHAIR ACCESSIBLE HALF RAMP</b> Model: APS-2005 ADA / Wheelchair Accessible Half Ramp</p>	\$700.00	\$0.00	\$700.00
1		<p><b>FREE SHIPPING PROMOTION</b> Model: FREESHIPPING FREE SHIPPING VALID UNTIL APRIL 3RD, 2026! ***A TOTAL SAVINGS OF \$3,253.47***</p>	\$0.00	\$0.00	\$0.00

I Accept!  
Let's Go

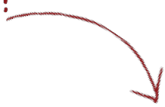

**Have questions about this quote?**  
Call **800-853-5316** or visit [BYOPLAYGROUND.COM](http://BYOPLAYGROUND.COM)

**Sub Total:** \$25,460.00  
**Sales Tax:** \$0.00  
**Shipping:** \$0.00  
**Total:** \$25,460.00

**I APPROVE THIS PROJECT AND AM READY TO PLACE MY ORDER:**

Thank you for the opportunity to quote your playground project. We accept Visa, Mastercard, Discover, personal & business checks and purchase orders from government entities. All items must be paid for in advance of order unless prior arrangements are approved. Approval and acceptance of this proposal may be executed by signing below and faxing or emailing back to the contact information listed above. By signing below you agree to the terms and conditions found here: <https://www.byoplayground.com/byo-terms-and-conditions>

Please note, sales tax calculations are calculated upon invoicing due to tax rate changes and/or change orders. If you believe you should be tax-exempt, please provide a tax exemption certificate prior to submitting a purchase order.

Authorized Purchaser: \_\_\_\_\_ Date: \_\_\_\_\_



# PROPOSAL #: 120823

**ACCOUNT:**  
BAKER COUNTY RECREATION DEPARTMENT

**DATE CREATED:**  
3/30/2026

**ACCOUNT REP:**  
Devon Ward

## PREPARED FOR:

**PRIMARY CONTACT:** Kayla Riggs  
**EMAIL:** kayla.riggs@bakercountyfl.org  
**PHONE NUMBER:** +19042593613x1  
**ORGANIZATION:** Baker County Recreation Department

## BILLING & SHIPPING:

**BILLING ADDRESS:** Baker County Recreation Department, 490 North Blvd W, Macclenny, FL 32063  
**SHIPPING ADDRESS:** Baker County Recreation Department, 9316 Odis Yarborough Road, Glen St. Mary, FL 32063



### COMMENTS & DETAILS:

Price quoted for delivery coordination and installation. NPC shall not be responsible for removing existing trees, limbs, roots etc. Unless otherwise noted price excludes: sitework, site security, core drilling or cutting concrete or asphalt, permits, lift gates, impact fees, debris/trash removal, and prevailing wages. Site must be clear, level and accessible at time of installation. The customer is responsible for marking all Private underground utilities, NPC will call for Public Utility Locate.

Qty	Product	Price	Total
1	 <p><b>PROFESSIONAL CERTIFIED INSTALLATION</b>                      Model: Installation                      Certified installation by professional playground installers. Price includes coordinating deliveries and unloading large equipment at the delivery address listed on this proposal/purchase order.</p>	\$13,248.00	\$13,248.00

Installation for BYO Quote #120820

- This installation quote covers the following items:
- Single Bay Bipod Swing Set w/2 strap seats - Blue yokes (7006-UP)
  - Wood Playground Mulch (BYO-510Z)
  - Duraliner (duraliner)
  - Playground Border with Surfacing Guide (APS-2003)
  - ADA / Wheelchair Accessible Half Ramp (APS-2005)
  - FREE SHIPPING PROMOTION (FREESHIPPING)
  - Solar Flare - Quick Ship (5653-PP-QS)

I Accept!  
Let's Go

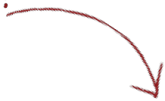

**Have questions about this quote?**  
Call **800-853-5316** or visit [BYOPLAYGROUND.COM](http://BYOPLAYGROUND.COM)

**Sub Total:** \$13,248.00  
**Sales Tax:** \$0.00  
**Shipping:** \$0.00  
**Total:** \$13,248.00

### I APPROVE THIS PROJECT AND AM READY TO PLACE MY ORDER:

Approval and acceptance of this proposal may be executed by signing below and faxing or emailing back to the contact information listed above. Unless prior arrangements are approved, a 50% deposit for NPC is due upon ordering. Balance is due Net 15 upon substantial completion. By signing below you agree to the terms and conditions found here:

<https://www.npcinstall.com/npc-terms-and-conditions>

DocuSign Envelope ID: B4B50DC3-0BA9-408E-95E6-96905DFE217E Pricing due to tax rate changes and/or change orders. If you believe you should be tax-exempt, please provide a tax exemption certificate prior to submitting a purchase order.

Authorized Purchaser: \_\_\_\_\_ Date: \_\_\_\_\_



## BAKER COUNTY BOARD OF COUNTY COMMISSIONERS AGENDA ITEM REQUEST FORM

The Board of County Commissioners meet on the 1<sup>st</sup> and 3<sup>rd</sup> Tuesday of each month at 5:00 p.m. at the Baker County Administration Office, Commission Chambers, 55 North Third Street, Macclenny, FL 32063. All agenda items should be submitted to County Administration via [sara.little@bakercountyfl.org](mailto:sara.little@bakercountyfl.org) and [kayla.riggs@bakercountyfl.org](mailto:kayla.riggs@bakercountyfl.org) no later than the Wednesday prior to the Commission meeting.

**Date of Submission:** April 2, 2026 **Meeting Date:** April 7, 2026

**Name of Submitter:** Sara Little **Department:** Administration

1. Nature and purpose of this agenda item:  
LSF Year 3 Funding agreement. The BOCC approved the LSF Year 3 budget at the March 17 meeting.  
LSF requires BOCC approval on the planned expenditures before a funding agreement is executed.

2. Recommended Motion/Action:  
Approve the agreement as submitted.  
Year 3 LSF Opioid Funding for local programs. This year funding allocation totals \$203,519 and will  
be used to continue 3 existing local programs.  
BCFR Paramedicine Program = \$41,975; Baker Prevention Coalition - Peer Specialist Position= \$53,900  
Baker Medical Services ROC Program = \$107,644

3. Will this item require a presentation? NA

4. Deadline for Completion: June 30 2026

5. Fiscal Impact Questions:

Is this item included in the current budget? No. Will require budget amendment

If item is grant related, is there a County match requirement? No match

Explain the procurement process for this request (attach necessary documentation): NA

**PURCHASE ORDER AGREEMENT**

This Agreement is entered into between Lutheran Services Florida, Inc., d/b/a LSF Health Systems (a Florida non-profit corporation), hereinafter referred to as the "LSF" and/or the "Managing Entity" and **Baker County Board of County Commissioners** herein after referred to as the "Contractor." The Contractor and LSF may be referred to herein individually as a "party" or collectively as "the parties." LSF and the Contractor agrees as follows:

**Effective and Ending Dates.** The terms of this Agreement shall be effective March 1, 2026, or upon execution, and shall continue through June 30, 2026.

This document provides direction and guidance for administration, implementation, and management of the **Florida Opioid Allocation and Statewide Response Agreement (Opioid Settlement) – Non-Qualified County (NQC) Funds** in the following County(ies): Baker.

**Services to be Provided.** This scope of work is for the Contractor to provide **funding to three distinct programs: Baker County Fire Rescue, Baker County Recovery Outreach Clinic, and Baker Prevention Coalition.**

**The Baker County Fire Rescue - Paramedicine Program will continue to offer services in-house to 911 over-utilizers, chronic overdose calls, and other substance use related problems in Baker County. This funding is for operational costs only. Staff salaries will be paid from other County funds.**

**Baker County Recovery Outreach Clinic will continue to focus on medication assisted treatment and psychotherapy for patients with substance use disorders. There is a heavy focus on peer support and therapy for patients receiving this care.**

**Baker Prevention Coalition will continue its Peer Specialist Position. This position focuses on providing peer support to Baker County residents with substance use disorders.**

**Section 1. Financial Consideration**

1.1. Award Amount

**Baker County Board of County Commissioners** has been awarded an amount not to exceed LSF approved Exhibit C and D - Projected Operating and Capital Budget, per county, if multiple counties are listed, for costs associated with administration of the services at its agency. Funding will be provided through OCA MSONQ - ME Opioid TF Non-Qualified Counties. This award is subject to availability of funds from the Department of Children and Families (DCF).

1.2. Budget

1.2.1 The Contractor shall submit a detailed, line-item budget to LSF identifying for each line the allowable items for the program, the projected or budgeted amount for each line item and narrative supporting the reasonableness and necessity of any unusual items.

1.2.1.1 Submissions must be separated by the counties listed in this Agreement, if multiple counties are listed.

- 1.2.2 All budgets and revisions thereto are subject to approval by LSF.
- 1.2.3 The Contractor may revise a budget by submitting same to the assigned Network Manager via electronic mail for approval.
- 1.2.4 Approved budgets shall be maintained in the official agreement file.
- 1.2.5 Modifications to the approved budget may not be effective retroactively.

### 1.3. Payment

This award shall be paid using a fixed rate methodology, subject to the availability of funds. The Contractor shall comply with the terms of such methodology, including quarterly fiscal reconciliation reports data reporting, as outlined below.

- 1.3.1 The total monthly payment amount shall be an equal proportion of the approved budget amount according to the agreement period and shall be included as a line item in the Contractor's Invoice with the following documentation provided as support.

- 1.3.1.1 The Contractor shall submit the **Exhibit O - Expenditure Reconciliation Report** using the form designated by LSF Health Systems, available on the website: <https://www.lsfhealthsystems.org/resources/#contractdocument>, which will outline expenses incurred by the Contractor. This report shall be submitted on or before the 8<sup>th</sup> of the month following the end of each quarter. The Managing Entity reserves the right to request monthly **Exhibit O - Expenditure Reconciliation reports**, depending on the Contractor's rate of spending, to perform an invoice reconciliation at any point within the fiscal year.

- a. Submissions must be separated by the counties listed in this Agreement, if multiple counties are listed.

- 1.3.1.2 All funds paid under the fixed rate methodology must be accounted for through this reconciliation process and any funding not accounted for is subject to repayment to LSF Health Systems.

- 1.3.1.3 LSF Health Systems reserves the right to request substantiating documentation to support the line items submitted by the Contractor in the **Exhibit O - Expenditure Reconciliation Report**.

- 1.3.1.4 All reports as required in Section 2.3 Required Reporting.

- 1.3.2 Reimbursement shall be made for actual, allowable expenditures within the limits of the latest version of the approved budget at the time that the invoice is processed.

- 1.3.3 The Contractor agrees that it will account for all payments from LSF according to generally accepted standard accounting principles.

## Section 2. Program Administration

- 2.1. The Opioid Settlement program will be administered according to approved DCF Children and Families Operating Procedure (CFOP) for the Opioid Settlement and any other approved DCF document

reflecting the program requirements, or latest version thereof, which can be found at following link using the applicable fiscal year: <https://www.myffamilies.com/services/substance-abuse-and-mental-health/samh-providers/managing-entities>.

2.2. Program requirements are as follows:

2.2.1 As reflected on the approved Schedule B of the Florida Opioid Allocation and Statewide Response Agreement, or latest version thereof.

2.2.2 As reflected on the approved DCF CFOP for the Opioid Settlement and any other approved DCF document reflecting the program requirements, or latest version thereof, which can be found at following link using the applicable fiscal year: <https://www.myffamilies.com/services/substance-abuse-and-mental-health/samh-providers/managing-entities>.

2.2.3 Service Tasks

2.2.3.1 The Contractor shall perform all tasks reflected on the **LSF approved Exhibit G – Submission of Information**.

- a. Submissions must be separated by the counties listed in this Agreement, if multiple counties are listed.

2.3. Required Reporting

2.3.1 **Expenditure Reconciliation Report:** This report shall be submitted on or before the 8<sup>th</sup> of the month following the end of each quarter. However, the Managing Entity reserves the right to request monthly Expenditure Reconciliation Reports, depending on the Contractor's rate of spending, to perform an invoice reconciliation at any point within the fiscal year.

2.3.1.1 Submissions must be separated by the counties listed in this Agreement, if multiple counties are listed.

2.3.2 The Contractor shall submit service data to LSF as required by LSF and DCF and shall submit the data electronically by the 8<sup>th</sup> of each month for the previous month's services, as specified by LSF and DCF and in accordance with the DCF Data System Guidelines.

2.3.2.1 Submissions must be separated by the counties listed in this Agreement, if multiple counties are listed.

2.3.3 Ad Hoc and additional reporting, at any frequency, may be required as determined necessary by LSF Health Systems or the Department of Children and Families.

2.3.3.1 Submissions must be separated by the counties listed in this Agreement, if multiple counties are listed.

2.3.4 Receipt of Opioid Settlement funds is an express acknowledgement of the obligation to report data on services funded by the Settlement. Recipients shall provide data to the Department of Children and Families (Department) through the Opioid Data Management System (ODMS) as

prescribed by the Department. Opioid Settlement funding is contingent upon satisfactory data reporting.

2.3.4.1 Submissions must be separated by the counties listed in this Agreement, if multiple counties are listed.

**Section 3. Documentation**

3.1. Cost

3.1.1 Professional Services Rendered: Invoices for professional services must include a general statement of the services provided, the time period covered by the invoice, the hourly rate, the number of hours worked, and the total payment required. Evidence of payment of the invoice must also be included.

3.1.2 Postage and Reproduction Expenses: Outside Contractor’s purchases must include invoices with evidence of payments made or receipts with itemization. In-house postage and reproduction must be supported by usage logs or similar reports.

Travel: Travel reimbursements shall be made in accordance with the Department’s CFOP 40-1, § 287.058(1)(b), Fla. Stat. and §112.061, Fla. Stat. Receipts for direct expenses (e.g., airfare, car rental, parking, tolls) shall be provided in support of such expenses. For mileage reimbursements, submissions shall include date(s) of travel, amount of mileage (support of mileage may include either map routes or odometer readings), purpose of travel, origin, and destination.

3.1.3 General Expenses not otherwise specified: Receipts or invoices with evidence of payment should be provided.

3.2. Services Rendered

3.2.1. The submission of service data in relation to the final invoice for payment shall be submitted to the Managing Entity no more than forty-five (45) days after the agreement ends or is terminated. If the Contractor fails to do so, all rights to payment are forfeited and the Managing Entity shall not honor any requests submitted after the aforesaid time period. Any payment due under the terms of this agreement may be withheld until performance of services and all reports due from the Contractor, and necessary adjustments thereto, have been approved by the Managing Entity.

3.2.2. Appropriate documentation shall be maintained in accordance with the applicable parameters established by statute, regulation, and code. Audit documentation shall be in accordance with 65E-14.021, F.A.C. The Contractor shall make such information available to LSF upon request and during monitoring of the program administration.

3.2.2.1. Staff timecards and a log of the date, time, number of participants, and the staff member conducting the class shall be the substantiating documentation for services and invoice back-up data.

3.2.3. The Contractor shall notify the Managing Entity’s Network Manager, in writing, at least ten (10) calendar days prior to any changes in services and/or locations where services are being provided. Changes must continue to meet the service needs of consumers without excessive time and travel requirements.

**Section 4. Miscellaneous**

## 4.1. Employment Screening

4.1.1. As described in CFOP 60-25, Chapter 2 (implementing §110.1127, F.S.), as a condition of initial and continued employment, the Contractor shall ensure that all staff, whether employees or independent Contractors, funded through this agreement as reflected in Sections 1.1 and 1.2, are screened by the Department in accordance with chapter 435, F.S., are of good moral character and meet the Level 2 Employment screening standards in §435.04, 110.1127, and 39.001(2), F.S., including:

- i. Employment history check,
- ii. Fingerprinting for all criminal record checks,
- iii. Statewide criminal and juvenile delinquency records checks through the Florida Department of Law Enforcement (FDLE),
- iv. Federal criminal records check from the Federal Bureau of Investigations via the FDLE, and
- v. Security background investigation, which may include local criminal records checks through local law enforcement agencies.
- vi. Attestation by each employee, subject to penalty, to meeting the requirements for qualifying for employment pursuant to chapter 435 and agreeing to inform the employer immediately if arrested for any of the disqualifying offenses while employed by the employer.

The Contractor shall sign the Florida Department of Children and Families Employment Screening Affidavit each State fiscal year (no two such affidavits shall be signed more than 13 months apart) for the term of the Agreement stating that all required staff have been screened or the Contractor is awaiting the results of the screening.

Additional guidance regarding background screening is incorporated herein by reference and may be located at: <https://www.myflfamilies.com/services/background-screening>.

## 4.2. Representations

4.2.1. The Contractor shall furnish all services, labor, equipment, and materials necessary and as may be required in the performance of this Agreement and all work performed pursuant to this Agreement shall be done in a professional manner.

4.2.2. The Contractor hereby represents to LSF, with full knowledge that LSF is relying upon these representations when entering into this Agreement that the Contractor has the professional expertise, experience, and manpower, as well as holds the necessary certifications and licenses

required to perform the services to be provided by the Contractor pursuant to the terms of this Agreement.

- 4.2.3. Prior to commencing to provide any services pursuant to this Agreement, Contractor shall provide copies of any and all business or professional licenses and certifications held by Contractor to LSF related to the performance of the services required by this Agreement, and they shall be incorporated and made a specific part of this Agreement, whether or not attached hereto. Upon renewal of such licenses or certifications during the term of this Agreement, Contractor shall provide evidence of such renewal or re-issuance to LSF.

#### 4.3. Terms and Conditions

- 4.3.1. Any changes to dates and fees must be submitted and approved by LSF. If circumstances arise that will require additional services and time, the Contractor will notify LSF and obtain written agreement prior to undertaking such activities. The Contractor shall perform all services, tasks and provide deliverables, including the quarterly reconciliation, and reports, as specified in this agreement.

#### 4.4. Health Insurance Portability and Accountability Act

- 4.4.1. The Contractor shall, where applicable, comply with the Health Insurance Portability and Accountability Act (42 U.S.C. 1320d.) as well as all regulations promulgated thereunder (45 CFR Parts 160, 162, and 164). In compliance with 45 CFR § 164.504(e), the Contractor shall comply with the provisions of Attachment IV to this agreement, governing the safeguarding, use and disclosure of Protected Health Information created, received, maintained, or transmitted by the Contractor or its subcontractors incidental to the Contractor's performance of this agreement.

#### 4.4.2. Business Associates

- 4.4.2.1. Portability and Accountability Act of 1996, and Standards for the Privacy and Security of Individually Identifiable Health Information, found at 45 C.F.R. Parts 160, 162 and 164, 42 C.F.R. and as amended by the Health Information Technology for Economic and Clinical Health Act, (collectively, "HIPAA"), LSF is required to protect certain individually identifiable health or other information ("Protected Health Information" or "PHI" including, but not limited to, PHI in an electronic form). Should LSF request that the Contractor share or disclose Client PHI with any of the other LSF designated business associates, LSF shall provide the Contractor with written direction indicating the name of the entity, confirmation that such entity is a business associate with a written business associate agreement with LSF and the specific information and/or data LSF desires the Contractor to disclose to or share with such other business associate and the Parties agree to execute any such additional agreements as necessary to complete such activities. For purposes of this Agreement, "Client" shall mean: any individual that is eligible to receive behavioral health services in accordance with DCF eligibility policies in the Service Area.

#### 4.5. Insurance

- 4.5.1. As applicable, the Contractor shall maintain continuous adequate liability insurance coverage during the existence of this Agreement and any renewal(s) and extension(s) thereof. With the exception of a State agency or subdivision as defined by subsection 768.28(2), F.S., by execution of this Agreement, the Contractor accepts full responsibility for identifying and determining the

type(s) and extent of liability insurance necessary to provide reasonable financial protections for the Contractor and the persons served to be served under this Agreement. The Managing Entity and its Network Service Contractors at all tiers are not covered by the State of Florida Risk Management Trust Fund for liability created by s. 284.30, F.S.

- 4.5.2. The Contractor acknowledges that, as an independent contractor, the Contractor, and its subcontractors, at all tiers are not covered by the State of Florida Risk Management Trust Fund for liability created by s. 284.30, F.S.
- 4.5.3. Upon the execution of this Agreement, the Contractor shall furnish the Managing Entity written verification supporting both the determination and existence of such insurance coverage and shall furnish verification of renewal or replacement thereof prior to the expiration or cancellation. The Managing Entity reserves the right to require additional insurance as specified in this Agreement.
- 4.5.4. The Contractor shall notify the Managing Entity within 30 calendar days if there is a modification to the terms of insurance including but not limited to, cancellation or modification to policy limits.
- 4.5.5. The Contractor shall obtain and provide proof to the Managing Entity and the Department of Comprehensive General Liability Insurance (broad form coverage), specifically including premises, fire, and legal liability to cover the Contractor and all its employees. The limits of the Contractor's coverage shall be no less than \$300,000 per occurrence with a minimal annual aggregate of no less than \$1,000,000.
- 4.5.6. If in the course of the performance of its duties under this Agreement any officer, employee, or agent of the Contractor operates a motor vehicle, the Managing Entity shall cause the Contractor, at all tiers, to obtain and provide proof to the ME and the Department of comprehensive automobile liability insurance coverage with limits no less than \$300,000 per occurrence with a minimal annual aggregate of no less than \$1,000,000.
- 4.5.7. If in the course of the performance of the duties of any Contractor, at all tiers, any officer, employee, or agent of the Contractor, provides any professional services or provides or administers any prescription drug or medication or controlled substance, the ME shall cause the Contractor, at all tiers, to obtain and provide proof to the ME and the Department of professional liability insurance coverage, including medical malpractice liability and errors and omissions coverage, to cover all employees and shall not exclude claims resulting from physical and sexual abuse. The limits of the coverage shall be no less than \$300,000 per occurrence with a minimal annual aggregate of no less than \$1,000,000.
- 4.5.8. The Managing Entity and the Department of Children and Families shall be exempt from, and in no way liable for, any sums of money that may represent a deductible or self-insured retention under any such insurance. The payment of any deductible on any policy shall be the sole responsibility of the Contractor purchasing the insurance.
- 4.5.9. All insurance policies, at all tiers, shall be provided by insurers licensed or eligible to do and that are doing business in the State of Florida. Each insurer must have a minimum rating of "A" by A. M. Best or an equivalent rating by a similar insurance rating firm and shall name the Managing Entity and the Department as an additional insured under the policy or policies. The Contractor shall use its best good faith efforts to cause the insurers issuing all such general, automobile, and professional liability insurance to use a policy form with additional insured provisions naming both DCF and the ME as additional insured or a form of additional insured endorsement acceptable to

ME in the reasonable exercise of its judgment. The ME reserves the right to require additional insurance. The limits of coverage under each policy maintained by the Contractor do not limit the Contractor's liability and obligations under this agreement. Upon the ME's request, the Contractor shall furnish the ME with written verification supporting the existence of such insurance coverage.

4.5.10. All such insurance proposed by the Contractor shall be submitted to and confirmed by the assigned Primary Point of Contact no later than execution initially and thereafter, updates shall be provided annually which reflect no lapse in insurance coverage.

#### 4.6. Indemnification

4.6.1. The Contractor shall be fully liable for the actions of its agents, employees, partners, or subcontractors and shall fully indemnify, defend and hold harmless LSF, State of Florida and its officers, agents, and employees, from suits, actions, damages, and costs of every name and description, including attorney's fees, arising from or relating to any alleged act or omission by the Contractor, its agents, employees, partners, or subcontractors, provided, however, that the Contractor shall not indemnify for that portion of any loss or damages caused by the negligence act or omission of LSF.

4.6.2. The Contractor shall fully indemnify, defend and hold harmless LSF, the State, from any suits, actions, damages, and costs of every name and description, including attorney's fees, arising from or relating to violation of infringement of a trademark, copyright, patent, trade secret or intellectual property rights, provided, however, that the foregoing obligation shall not apply to LSF's misuse or modification of Contractor's products or LSF's operation or use of Contractor's products in a manner not contemplated by the agreement or the purchase order. If any product is the subject of an infringement suit or in the Contractor's opinion is likely to become the subject of such a suit, the Contractor may at its sole expense procure for LSF the right to continue using the product or modify it to become non-infringing. If the Contractor is not reasonably able to modify or otherwise secure LSF the use, LSF shall not be liable for any royalties. The Contractor's indemnification for violation or infringement of a trademark, copyright, patent, trade secret or intellectual property rights shall encompass all such items used or accessed by the Contractor, its officers, agents or subcontractors in the performance of this agreement or delivered to LSF for the use of LSF, its employees, agents, or contractors.

4.6.3. The Contractor shall protect, defend, and indemnify, including attorney's fees and costs, LSF for any and all claims and litigation (including litigation initiated by LSF) arising from or relating to Contractor's claim that a document contains proprietary or trade secret information that is exempt from disclosure or the scope of the Contractor's redaction.

4.6.4. LSF shall not be liable for any costs, expense, or compromise incurred or made by the Contractor in any legal action. The Contractor's inability to evaluate liability or its evaluation of liability shall not excuse its duty to defend and indemnify after receipt of notice. Only an adjudication or judgment after the highest appeal is exhausted finding LSF negligent shall excuse the Contractor of performance under this provision, in which case LSF shall have no obligation to reimburse the Contractor for costs of its defense. If the Contractor is an agency or subdivision of the State, its obligation of indemnify, defend, and hold harmless LSF shall be to the extent permitted by section 768.28, F.S. or other applicable law, and without waiving the limits of sovereign immunity.

#### 4.7. Governing Law and Compliance

#### 4.7.1. Governing Law

- 4.7.1.1. The validity, enforceability, and interpretation of this Agreement shall be determined and governed by the laws of the State of Florida, as well as applicable federal laws. The Parties agree that jurisdiction for any dispute, action, claim or alternative dispute resolution proceeding regarding this Agreement shall reside in Duval County, Florida.

#### 4.7.2. Florida Regulatory Governance

- 4.7.2.1. This Agreement, the attachments, and the performance thereof, are subject to the requirements and regulations promulgated by and specific verbiage required by DCF.

#### 4.7.3. Corporate Compliance

- 4.7.3.1. During the term of this Agreement, each Party shall: (i) ensure that it is duly organized, validly existing and in good standing under the laws of Florida; (ii) maintain all requisite federal, state and local authority, permits and licenses necessary or appropriate to operate and to carry out its obligations under this Agreement; (iii) monitor its performance of administrative functions on an ongoing basis to ensure compliance with applicable DCF performance standards and guidelines; and (iv) notwithstanding any term or provision in this Agreement to the contrary, remain ultimately responsible for assuring that it is operating in accordance with all applicable federal, state and local laws, rules, regulations and ordinances.

#### 4.7.4. General Provisions

- 4.7.4.1. Notwithstanding anything in this Agreement to the contrary, the Parties acknowledge and agree that each Party is subject to the Florida Public Records Act under the Florida Contract and under Chapter 119, Florida Statutes. Nonetheless, in the event that a Party becomes legally compelled to disclose any of the Confidential Proprietary Information (the "Compelled Party"), the Compelled Party will provide the other Party with prompt notice thereof so that the other Party may seek a protective order or other appropriate remedy. In the event that such protective order or other remedy is not obtained by the other Party, the Compelled Party will furnish or cause to be furnished only that minimum portion of the Confidential Proprietary Information which the Compelled Party is legally required to furnish.

#### 4.7.4.2. Severability

The illegality, unenforceability, or ineffectiveness of any provision of this Agreement shall not affect the legality, enforceability, or effectiveness of any other provision of this Agreement. If any provision of this Agreement, or the application thereof shall, for any reason and to any extent, be deemed invalid or unenforceable, neither the remainder of this Agreement, nor the application of the provision to other persons, entities, or circumstances, nor any other instrument referred to in this Agreement shall be affected thereby, but instead shall be enforced to the maximum extent permitted by law.

#### 4.9.5 Authority to Bind

By signature below, each signatory represents and warrants that such person is duly authorized to enter into this Agreement on the respective Party's behalf and is duly authorized to bind such Party to the terms applicable to each.

#### 4.9.6 Typewritten or Handwritten Provisions

Typewritten or handwritten provisions that are inserted in this Agreement or attached to this Agreement as addenda or riders shall not be valid unless such provisions are initialed by both signatories to this Agreement.

#### 4.9.7 Counterparts: Facsimile Execution and Captions

This Agreement may be executed and delivered: (a) in any number of counterparts, each of which will be deemed an original, but all of which together will constitute one and the same instrument; and/or (b) by facsimile, in which case the instruments so executed and delivered shall be binding and effective for all purposes; and/or (c) by email communication to the parties identified in this agreement. The captions in this Agreement are for reference purposes only and shall not affect the meaning of terms and provisions herein.

#### 4.9.8 Entire Agreement

This Agreement, including any documents incorporated by reference hereto, contains all the terms and conditions agreed upon by the parties regarding the subject matter of this Agreement. Any prior agreements, promises, negotiations or representations of or between the Parties, either oral or written, relating to the subject matter of this Agreement, which are not expressly set forth in this Agreement are null and void and of no further force or effect.

#### 4.9.9 Cancellation of Agreement

This Agreement may be terminated by either party at any time, regardless of reason, with thirty (30) days written notice. No termination shall prejudice the Contractor's rights to payments for services properly completed prior to the effective date of termination. LSF reserves the right to unilaterally cancel this Agreement immediately upon discovery of fraud or misuse of public funds.

The parties' authorized representatives have executed this sixteen-page Agreement to be effective this 1<sup>st</sup> day of March 2026, or upon execution.

**Baker County Board of County Commissioners**

**Lutheran Services Florida, Inc. d/b/a LSF Health Systems**

\_\_\_\_\_  
Signature

\_\_\_\_\_  
Date

\_\_\_\_\_  
Signature

\_\_\_\_\_  
Date

\_\_\_\_\_  
Printed Name

\_\_\_\_\_  
Title

\_\_\_\_\_  
Dr. Christine Cauffield  
Printed Name

\_\_\_\_\_  
CEO  
Title

**The parties agree that any future amendment(s) replacing this page will not affect the above execution.**

Federal Tax ID # (or SSN): 59-6000508

Contractor FY Ending Date: 9/30

## ATTACHMENT IV

This Attachment contains the terms and conditions governing the Network Service Provider's access to and use of Protected Health Information and provides the permissible uses and disclosures of protected health information by the Provider, also called "Business Associate."

### Section 1. Definitions

#### 1.1 Catch-all definitions:

The following terms used in this Attachment shall have the same meaning as those terms in the HIPAA Rules: Breach, Data Aggregation, Designated Record Set, Disclosure, Health Care Operations, Individual, Minimum Necessary, Notice of Privacy Practices, Protected Health Information, Required by Law, Security Incident, Subcontractor, Unsecured Protected Health Information, and Use.

#### 1.2 Specific definitions:

- 1.2.1 "Business Associate" shall generally have the same meaning as the term "business associate" at 45 CFR 160.103, and for purposes of this Attachment shall specifically refer to the Network Service Provider.
- 1.2.2 "Covered Entity" shall generally have the same meaning as the term "covered entity" at 45 CFR 160.103, and for purposes of this Attachment shall refer to the Managing Entity and/or the Department.
- 1.2.3. "HIPAA Rules" shall mean the Privacy, Security, Breach Notification, and Enforcement Rules at 45 CFR Part 160 and Part 164.
- 1.2.4. "Subcontractor" shall generally have the same meaning as the term "subcontractor" at 45 CFR 160.103 and is defined as an individual to whom a business associate delegates a function, activity or service, other than in the capacity of a member of the workforce of such business associate.

### Section 2. Obligations and Activities of Business Associate

#### 2.1 Business Associate agrees to:

- 2.1.1 Not use or disclose protected health information other than as permitted or required by this Attachment or as required by law;
- 2.1.2 Use appropriate administrative safeguards as set forth at 45 CRF164.308, physical safeguards as set forth at 45 CRF164.310, and technical safeguards as set forth at 45 CFR 164.312; including, policies and procedures regarding the protection of PHI and/or ePHI set forth at 45 CRF 164.316 and the provisions of training on such policies and procedures to applicable employees, independent contractors and volunteers, that reasonably and appropriately protect the confidentiality, integrity, and availability of the PHI and/or ePHI that the Network Service Provider creates, receives, maintains or transmits on behalf of the Managing Entity and/or the Department;
- 2.1.3 Acknowledge that (a) the foregoing safeguards, policies and procedures requirements shall apply to the Business Associate in the same manner that such requirements apply to the Managing Entity and/or the Department, and (b) the Business Associates and their Subcontractors are directly liable under the

- civil and criminal enforcement provisions set forth at Section 13404 of the HITECH Act and 45 CFR 164.500 and 164.502(E) of the Privacy Rule (42 U.S.C. 1320d-5 and 1320d-6), as amended, for failure to comply with the safeguards, policies and procedures requirements and any guidance issued by the Secretary of Health and Human Services with respect to such requirements;
- 2.1.4 Report to covered entity any use or disclosure of protected health information not provided for by this Attachment of which it becomes aware, including breaches of unsecured protected health information as required at 45 CFR 164.410, and any security incident of which it becomes aware;
  - 2.1.5 Notify the Managing Entity's Network Manager as soon as possible, but no later than five (5) business days following the determination of any breach or potential breach of personal and confidential departmental data;
  - 2.1.6 Notify the Managing Entity's Network Manager within (24) hours of notification by the US Department of Health and Human Services of any investigations, compliance reviews or inquiries by the US Department of Health and Human Services concerning violations of HIPAA (Privacy, Security Breach).
  - 2.1.7 Provide any additional information requested by the Managing Entity and/or the Department for purposes of investigating and responding to a breach;
  - 2.1.8 Provide at Business Associate's own cost notice to affected parties no later than 45 days following the determination of any potential breach of personal or confidential departmental data as provided in §817.5681, Fla. Stat.;
  - 2.1.9 Implement at Business Associate's own cost measures deemed appropriate by the Managing Entity and/or the Department to avoid or mitigate potential injury to any person due to a breach or potential breach of personal and confidential departmental data;
  - 2.1.10 Take immediate steps to limit or avoid the recurrence of any security breach and take any other action pertaining to such unauthorized access or disclosure required by applicable federal and state laws and regulations regardless of any actions taken by the Managing Entity or the Department ;
  - 2.1.11 In accordance with 45 CFR 164.502(e)(1)(ii) and 164.308(b)(2), if applicable, ensure that any subcontractors that create, receive, maintain or transmit protected health information on behalf of the Business Associate agree to the same restrictions, conditions, and requirements that apply to the Business Associate with respect to such information. Business Associates must attain satisfactory assurance in the form of a written contract or other written agreement with their business associates or subcontractors that meets the applicable requirements of 45 CFR 164.504(e)(2) that the Business Associate or Subcontractor will appropriately safeguard the information. For prior contracts or other arrangements, the provider shall provide written certification that its implementation complies with the terms of 45 CFR 164.532(d);
  - 2.1.12 Make available protected health information in a designated record set to covered entity as necessary to satisfy covered entity's obligations under 45 CFR 164.524;
  - 2.1.13 Make any amendment(s) to protected health information in a designated record set as directed or agreed to by the covered entity pursuant to 45 CFR 164.526, or take other measures as necessary to satisfy covered entity's obligations under 45 CFR 164.526;
  - 2.1.14 Maintain and make available the information required to provide an accounting of disclosures to the covered entity as necessary to satisfy covered entity's obligations under 45 CFR 164.528;

- 2.1.15 To the extent the Business Associate is to carry out one or more of covered entity's obligation(s) under Subpart E of 45 CFR Part 164, comply with the requirements of Subpart E that apply to the covered entity in the performance of such obligation(s); and
- 2.1.16 Make its internal practices, books, and records available to the Secretary of the U.S. Department of Health and Human Services for purposes of determining compliance with the HIPAA Rules.

### **Section 3. Permitted Uses and Disclosures by Business Associate**

- 3.1 The Business Associate may only use or disclose protected health information covered under this Attachment as listed below:
  - 3.1.1 The Business Associate may use and disclose the Managing Entity's or Department's PHI and/or ePHI received or created by Business Associate (or its agents and subcontractors) in performing its obligations pursuant to this Attachment.
  - 3.1.2 The Business Associate may use the Managing Entity's or Department's PHI and/or ePHI received or created by Business Associate (or its agents and subcontractors) for archival purposes.
  - 3.1.3 The Business Associate may use PHI and/or ePHI created or received in its capacity as a Business Associate of the Managing Entity for the proper management and administration of the Business Associate, if such use is necessary (a) for the proper management and administration of Business Associate or (b) to carry out the legal responsibilities of Business Associate.
  - 3.1.4 The Business Associate may disclose PHI and/or ePHI created or received in its capacity as a Business Associate of the Managing Entity for the proper management and administration of the Business Associate if (a) the disclosure is required by law or (b) the Business Associate (1) obtains reasonable assurances from the person to whom the PHI and/or ePHI is disclosed that it will be held confidentially and used or further disclosed only as required by law or for the purpose for which it was disclosed to the person and (2) the person agrees to notify the Business Associate of any instances of which it becomes aware in which the confidentiality and security of the PHI and/or ePHI has been breached.
  - 3.1.5 The Business Associate may aggregate the PHI and/or ePHI created or received pursuant this Attachment with the PHI and/or ePHI of other covered entities that Business Associate has in its possession through its capacity as a Business Associate of such covered entities for the purpose of providing the Managing Entity and/or the Department of Children and Families with data analyses relating to the health care operations of the Managing Entity or the Department (as defined in 45 C.F.R. §164.501).
  - 3.1.6 The Business Associate may de-identify any and all PHI and/or ePHI received or created pursuant to this Attachment, provided that the de-identification process conforms to the requirements of 45 CFR 164.514(b).
  - 3.1.7 Follow guidance in the HIPAA Rule regarding marketing, fundraising and research located at Sections 45 CFR 164.501, 45 CFR 164.508 and 45 CFR 164.514.

**Section 4. Provisions for Covered Entity to Inform Business Associate of Privacy Practices and Restrictions**

- 4.1 Covered entity shall notify Business Associate of any limitation in the notice of privacy practices of covered entity under 45 CFR 164.520, to the extent that such limitation may affect Business Associate's use or disclosure of protected health information.
- 4.2 Covered entity shall notify Business Associate of any changes in, or revocation of, the permission by an individual to use or disclose his or her protected health information, to the extent that such changes may affect Business Associate's use or disclosure of protected health information.
- 4.3 Covered entity shall notify Business Associate of any restriction on the use or disclosure of protected health information that covered entity has agreed to or is required to abide by under 45 CFR 164.522, to the extent that such restriction may affect Business Associate's use or disclosure of protected health information.

**Section 5. Termination**

5.1 Termination for Cause

5.1.1 Upon the Managing Entity's knowledge of a material breach by the Business Associate, the Managing Entity shall either:

- 5.1.1.1 Provide an opportunity for the Business Associate to cure the breach or end the violation and terminate the Agreement or discontinue access to PHI if the Business Associate does not cure the breach or end the violation within the time specified by the Managing Entity;
- 5.1.1.2 Immediately terminate this Agreement or discontinue access to PHI if the Business Associate has breached a material term of this Attachment and does not end the violation; or
- 5.1.1.3 If neither termination nor cure is feasible, the Managing Entity shall report the violation to the Department of Children and Families and the Secretary of the Department of Health and Human Services.

5.2 Obligations of Business Associate Upon Termination

5.2.1 Upon termination of this Attachment for any reason, Business Associate, with respect to protected health information received from covered entity, or created, maintained, or received by Business Associate on behalf of covered entity, shall:

- 5.2.1.1 Retain only that protected health information which is necessary for Business Associate to continue its proper management and administration or to carry out its legal responsibilities;
- 5.2.1.2 Return to covered entity, or other entity as specified by the Managing Entity or, if permission is granted by the Managing Entity, destroy the remaining protected health information that the Business Associate still maintains in any form;
- 5.2.1.3 Continue to use appropriate safeguards and comply with Subpart C of 45 CFR Part 164 with respect to electronic protected health information to prevent use or disclosure of the protected health information, other

- than as provided for in this Section, for as long as Business Associate retains the protected health information;
- 5.2.1.4 Not use or disclose the protected health information retained by Business Associate other than for the purposes for which such protected health information was retained and subject to the same conditions set out at paragraphs 3.1.3 and 3.1.4 above under "Permitted Uses and Disclosures By Business Associate" which applied prior to termination; and
  - 5.2.1.5 Return to covered entity, or other entity as specified by the Managing Entity or, if permission is granted by the Managing Entity, destroy the protected health information retained by Business Associate when it is no longer needed by Business Associate for its proper management and administration or to carry out its legal responsibilities.
  - 5.2.1.6 The obligations of Business Associate under this Section shall survive the termination of this Attachment.

## **Section 6. Miscellaneous**

- 6.1 A regulatory reference in this Attachment to a section in the HIPAA Rules means the section as in effect or as amended.
- 6.2 The Parties agree to take such action as is necessary to amend this Attachment from time to time as is necessary for compliance with the requirements of the HIPAA Rules and any other applicable law.
- 6.3 Any ambiguity in this Attachment shall be interpreted to permit compliance with the HIPAA Rules.



## BAKER COUNTY BOARD OF COUNTY COMMISSIONERS

### AGENDA ITEM REQUEST FORM

The Board of County Commissioners meet on the 1<sup>st</sup> and 3<sup>rd</sup> Tuesday of each month at 5:00 p.m. at the Baker County Administration Office, Commission Chambers, 55 North Third Street, Macclenny, FL 32063. All agenda items should be submitted to County Administration via [sara.little@bakercountyfl.org](mailto:sara.little@bakercountyfl.org) and [kayla.riggs@bakercountyfl.org](mailto:kayla.riggs@bakercountyfl.org) no later than the Wednesday prior to the Commission meeting.

**Date of Submission:** 3/30/2026 **Meeting Date:** 4/7/2026

**Name of Submitter:** Sara Little **Department:** Animal Control

1. Nature and purpose of this agenda item:  
staff sought quotes for the pressure washing and painting of the exterior Animal Control building.  
three quotes were recieved per purchasing policy, Capital Grounds Solutions, LLC in the amount of \$10,500.00  
Plumb Level Contruuction totaling \$14,740.00, and Muncy Contracting totaling \$11,000.00.

2. Recommended Motion/Action:  
staff recommends approval of Capital Grounds Solutions, LLC. totaling \$10,500.00.

3. Will this item require a presentation? No, Item backup document only.

4. Deadline for Completion: before end of fiscal year.

5. Fiscal Impact Questions:

Is this item included in the current budget? yes, BOCC approved \$15,000.00 at the final budget hearing.

If item is grant related, is there a County match requirement? na

Explain the procurement process for this request (attach necessary documentation): staff sought quotes per purchasing policy, staff makes recommendation to lowest quote. BOCC approves.

**CAPITAL GROUNDS SOLUTIONS, LLC**  
**9073 PONDEROSA TRAIL**  
**GLEN ST. MARY, FL 32040**

---

**BAKER COUNTY BOCC:**

Animal Control  
14564 Deputy Dawg Ln.  
Macclenny, FL 32063

**DATE:** 3/28/2026

## QUOTE

**SCOPE OF WORK:**

Pressure washing all of the exterior of the animal control building. Painting of exterior includes brick walls, windows, doors, and window frames. All material and labor included in quote which includes, exterior high durable, weather resistant paint, three different paint colors (Earl grey for main building, black and white for windows, doors, etc.) as requested by director.

**TOTAL OF JOB: \$10,500.00 with a 50% downpayment. Remainder due upon completion.**

# PLUMB LEVEL CONSTRUCTION

289 SW BEDENBAUGH LANE  
LAKE CITY, FL 32025  
(386) 365-5264 OR (386) 792-4061  
KEVIN@PLUMBLEVELC.COM

Date: March 13, 2026

**PROPOSAL SUBMITTED TO:**

Name: Baker County Animal Control  
Address: 14564 Deputy Dawg Lane  
City: Macclenny  
State: FL Zip Code: 32063

**WORK TO BE PERFORMED AT:**

Job Location: \_\_\_\_\_  
Address: \_\_\_\_\_  
City: \_\_\_\_\_ State: \_\_\_\_\_ Zip: \_\_\_\_\_  
Date of Plans: \_\_\_\_\_

**WE HEREBY PROPOSE TO FURNISH ALL MATERIALS AND PERFORM ALL LABOR NECESSARY FOR THE COMPLETION OF:** Exterior Painting

**ALL MATERIAL IS GUARANTEED TO BE AS SPECIFIED, AND THE ABOVE WORK PERFORMED IN ACCORDANCE WITH THE DRAWINGS AND SPECIFICATIONS SUBMITTED FOR THE ABOVE WORK AND COMPLETED IN A SUBSTANTIAL WORKMANLIKE MANNER FOR THE SUM OF:**  
\$14,740.00.

**WITH PAYMENTS TO BE MADE AS FOLLOWS:** Due Upon Completion

ANY ALTERCATION OR DEVIATION FROM THE ABOVE SPECIFICATIONS WILL BE EXECUTED ONLY UPON APPROVAL. ALL AGREEMENTS ARE CONTINGENT UPON STRIKES, ACCIDENTS OR DELAYS BEYOND OUR CONTROL. ANY ALTERCATION ARISING FROM THIS CONTRACT IS TO BE PAID FOR BY THE HOMEOWNER.

**OTHER COMMENTS:**

\*Plumb Level Construction proposes to perform the labor and materials to power wash, apply loxon masonry sealer to existing chalky surface and apply epoxy block fill coating to 3060 sqft exterior of the baker county animal control bldg.

**ACCEPTANCE OF PROPOSAL:**

THE ABOVE PRICES, SPECIFICATIONS, AND CONDITIONS ARE SATISFACTORY AND ARE HEREBY ACCEPTED. YOU ARE AUTHORIZED TO DO WORK AS SPECIFIED. PAYMENTS WILL BE MADE AS OUTLINED ABOVE.

DATE ACCEPTED: \_\_\_\_\_

SIGNATURE: \_\_\_\_\_

SIGNATURE: \_\_\_\_\_

SIGNATURE: \_\_\_\_\_

RESPECTFULLY SUBMITTED BY: KEVIN L. BEDENBAUGH / PLUMB LEVEL CONSTRUCTION CO., LLC  
CERTIFIED GENERAL CONTRACTOR #CGC1516042  
CERTIFIED ROOFING CONTRACTOR #CCC1329482

CGC#1521139

CCC# 1330125



213 E. Macclenny Avenue  
Macclenny, FL 32063

## CONTRACT-PROPOSAL

Name: Baker County Animal Control/Shannon  
Whitfield

Address: 14564 Deputy Dawg Lane, Macclenny, FL 32063

Number: 904-334-5870

Email: Shannon.whitfield@bakercountyfl.org

**Proposed Scope of Work: Full exterior pressure with cleaner. Full exterior paint with very high quality, long lasting, DTF exterior paint. Paint doors and window trim (three colors if desired: block, doors, trim). *\*\*\* Optional: if approved, would repair multiple areas of soffit, secondary to damage caused by storms. Take down old vinyl siding in 4 gabled areas and replace with hardiboard and trim, caulk and paint.***

**TOTAL COST OF SCOPE OF WORK LISTED ABOVE: \$11,000 without option detailed above. \$15,000.00 total, including option. Would require 50% deposit up front at contract signing and remaining balance to be paid after completion of project. Any changes, such as replacement of rotten wood, flashing, etc., will be an additional charge and require a change order. This change order will require approval of both customer and owner.**

**If estimate agreed upon, signed and dated, this proposal will automatically be viewed as the contract.**

---

Homeowner/Customer

Date

---

**Joe Muncy, Owner Muncy Contracting LLC Date**



## BAKER COUNTY BOARD OF COUNTY COMMISSIONERS

### AGENDA ITEM REQUEST FORM

The Board of County Commissioners meet on the 1<sup>st</sup> and 3<sup>rd</sup> Tuesday of each month at 5:00 p.m. at the Baker County Administration Office, Commission Chambers, 55 North Third Street, Macclenny, FL 32063. All agenda items should be submitted to County Administration via [sara.little@bakercountyfl.org](mailto:sara.little@bakercountyfl.org) and [kayla.riggs@bakercountyfl.org](mailto:kayla.riggs@bakercountyfl.org) no later than the Wednesday prior to the Commission meeting.

**Date of Submission:** April 2, 2026 **Meeting Date:** April 7, 2026

**Name of Submitter:** Kayla Riggs **Department:** TDC

1. Nature and purpose of this agenda item:  
Suni Phillips asked the TDC Board to use funds for advertising for the Beat the Heat event in the amount of \$3800.00. TDC approved on April 1, 2026 and staff recommends the approval of the use of TDC Funds be approved by BOCC.

2. Recommended Motion/Action:  
approval of funding request for the use of TDC Funds.

3. Will this item require a presentation? No, Item backup document only.

4. Deadline for Completion: asap.

5. Fiscal Impact Questions:

Is this item included in the current budget? yes, TDC funds advertising for tourist events.

If item is grant related, is there a County match requirement? na

Explain the procurement process for this request (attach necessary documentation): The host of the event presents request to the TDC Board, once TDC approves the final recommendation is through the BOCC.

**SNK** RODEO PRODUCTIONS  
**BEAT THE HEAT**

# BULLS & BARRELS

To whom it may concern,

With the continued success of our yearly Baker County Bucking Battle & Rodeo we have decided to bring more rodeo opportunities to our area. On March 27 & 28, 2026 we will be hosting our third annual "Beat The Heat" event which will feature bull riding, barrel racing, and crowd favorite mutton busting.

To bring the biggest and best show possible to Baker County we are requesting \$3,800 advertising dollars from the Baker County Tourism Development Council to help with such advertising expenses outlined below.

- Funds will be used in the following areas to help promote and advertise not only the rodeo itself but Baker County as well:
  - o Print promotions such as flyers, newspaper ads and banners - \$1,500.
  - o Social Media Campaigns to reach the widest audience possible - \$500.
  - o Radio advertising - \$500.
  - o Roadside signs for local area and neighboring counties - \$500.
  - o County EMS Services - \$800.

If you have any questions or need more information, please do not hesitate to reach out or give me a call.

Thank you for your time,

*Suni Phillips*

Suni Phillips, Producer  
SNK Rodeo Productions, LLC  
904-334-2378/sphil005@icloud.com

## 2026 Beat the Heat Budget

Bulls \$4000 + \$2,000 added money

JR Bulls \$500 + \$300 added money

Barrels \$2000 added money

JR Barrels \$300 added money

Mutton Busting \$750

Bleachers \$4000

Announcer \$2500

Sound person \$1000

Clown \$2500

Pick up men \$1,000

Bull fighters \$1,000

Secretaries \$1,000

Back pen & arena help \$3,000

Gate workers \$800

Insurance (2 million liability) \$800

Advertising \$3,800

County EMS Services \$800

Total: \$32,050

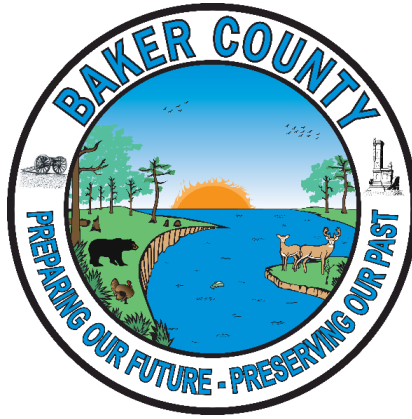

## Applicant

---

Business: SNK Rodeo Productions, LLC Non-Profit: \_\_\_\_\_ Individual: X \_\_\_\_\_

Contact: Suni Phillips Phone: 904-334-2378 Email: sphil005@icloud.com

Address: 9412 Tower Rd Glen St Mary, FL 32040

Second Contact: \_\_\_\_\_

## Event Details

---

Event Name: Beat the Heat Bulls & Barrels Start Date/Time: March 27 & 28, 2026 8 pm nightly

Event Type: Rodeo End Date/Time: March 27 & 28, 2026 10 pm nightly

Event Nature: Rodeo Age of Event: 3 years Occurrence: Yearly

Location/Venue: Baker County Fairgrounds Arena

Address: 5576 Lauramore Rd Macclenny, FL 32063

Project Participants: 75-100 Projected Attendance: 2500-3500 Projected Overnight Stays: 150+

The process to collect hotel data is: \_\_\_\_\_  
\_\_\_\_\_  
\_\_\_\_\_

Requested amount of money from TDC:

Sponsorship Level (If Applicable):

\$3800

**REQUEST FOR FUNDING MUST INCLUDE FULL BUDGET FOR EVENT AS ATTACHMENT**

Years of TDC Sponsorship: 3

Other Sponsors listed: \_\_\_\_\_

## Audience Profile

---

Local: % 40

North Florida %: 25

% Age 0-5: 5

Florida %: 25

% Age 5-12: 5

Southeast %: 10

% Age 13-17: 5

National %: \_\_\_\_\_

% Age 18-24: 35

International %: \_\_\_\_\_

% Age 25-34: 25

% Age 35-44: 10

Target Groups: all ages

% Age 45-54: 5

% Age 55-64: 5

% Age 65+: 5

## Advertising and Promotion

---

The number of people who will directly or indirectly be informed of our sponsorship: Approx 5,000+

Please describe your method to provide reach proof of performance: From Facebook share and view analytics is shows \_\_\_\_\_  
the audience demographics and reach \_\_\_\_\_

Please list your advertising methods: Facebook, road signage, posters, other print materials, radio ads, banners

Does this event have a social media presence?

Facebook Yes, Facebook event "Beat the Heat Bulls & Barrels"

Instagram \_\_\_\_\_

Twitter \_\_\_\_\_

YouTube \_\_\_\_\_

Other \_\_\_\_\_

Site has Baker County TDC Logo? Sponsors with logos are posted in facebook event including all road signage as well

Website: Facebook event and on SNK Rodeo Productions page \_\_\_\_\_

If so, Where at? \_\_\_\_\_

Does this event have prelaunch activities? yes, ticketfox.com

Does this event have post event visibility? No

Location: \_\_\_\_\_

Will Baker County be mentioned in public relations material? Yes

**ALL PROMOTIONAL ITEMS AND ADVERTISEMENT MUST INCLUDE BAKER COUNTY SEAL AND THE FOLLOWING STATEMENT: "SPONSORED BY THE BAKER COUNTY TOURIST DEVELOPMENT COUNCIL".**

### Licensing, Video and Photo Rights

---

Comments: \_\_\_\_\_

### Additional Comments

---

\_\_\_\_\_  
\_\_\_\_\_  
\_\_\_\_\_



TDC Approved \$15,000.00 on 4/1/26  
Danny Norton motioned, Commissioner  
Hartley seconded.



March 3, 2026

Dear Members of the Tourist Development Council,

On behalf of the Baker County Chamber of Commerce, I respectfully submit this request for \$15,000 in Tourist Development Council funding to support our 2026 Independence Day Celebration, scheduled for June 27, 2026, at Memorial (Duck Pond) Park in Macclenny.

Now in its 14th year, the Independence Day Celebration has become one of Baker County's premier annual community events. This free public celebration features live entertainment, food vendors, family-friendly activities, and a professional fireworks display. We anticipate attendance between 1,500 and 2,000 participants, along with approximately 30 vendors and community partners.

Promotion for the event will include radio advertising, targeted social media campaigns, coverage in the Baker County Press, and coordinated outreach through the Chamber's communication channels. All promotional materials will prominently display the Baker County seal and include the required statement recognizing sponsorship by the Baker County Tourist Development Council. The TDC will also be recognized across event signage and social media platforms.

The Independence Day Celebration strengthens Baker County's visibility as a welcoming, family-oriented destination. By investing in this event, the TDC helps us showcase our community, support local vendors, and contribute to the positive perception and economic vitality of Baker County.

We appreciate your continued partnership and consideration of this request. I look forward to presenting this proposal at the upcoming TDC meeting and am happy to provide any additional information needed.

Sincerely,

A handwritten signature in black ink that reads "Dillon E. Pullen".

Dillon Pullen  
*Executive Director*

**Baker County Chamber of Commerce**

20 East Macclenny Avenue Macclenny, Florida 32063

Office: 904.259.6433 · Email: [info@bakerchamberfl.com](mailto:info@bakerchamberfl.com) · Website: [www.bakerchamberfl.com](http://www.bakerchamberfl.com)

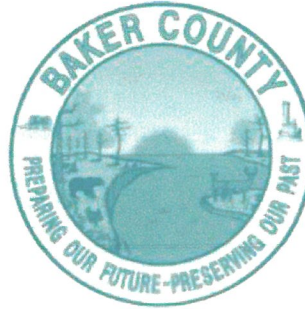

## TOURIST DEVELOPMENT COUNCIL

### APPLICATION REQUIREMENTS

- All funding requests will be broken down into 2 payments. (80/20) 80% will be provided in advance upon approved application. Upon receipt of invoices that match funding request staff will release the final 20% payment.
- Receipts must match funds request. Any remaining funds must be returned to the County.
- Applicant(s) or a Representative must present funding request to TDC Board during meeting. Appearance via telephone is available for valid reason. If not present, request will not be discussed.
- Applications must be submitted to the TDC at least 3 days prior to the TDC meeting for review.

**By signing below applicant acknowledges receipt of application requirements.**

*Dillon C. Pullen*  
\_\_\_\_\_  
**Funding Request Application**

March 3, 2026

\_\_\_\_\_  
**Date**

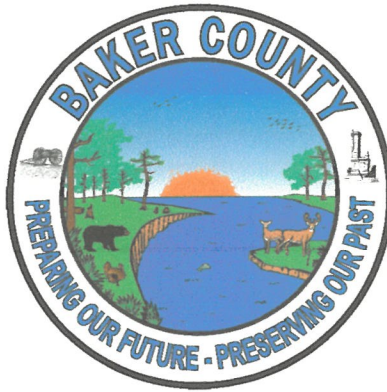

## Applicant

---

Business: Baker County Chamber of Commerce  
Non-Profit:  Individual:

Contact: Dillon C. Pullen  
Phone: (904) 259-6433 Email: Dpullen@bakerchamberfl.com

Address: 20 East Macclenny Ave., Macclenny, Florida, 32063

Second Contact:

---

## Event Details

---

Event Name: Independence Day Celebration  
Start Date/Time: June 27, 2026 7:00pm

Event Type: Free community celebration  
End Date/Time: June 27, 2026 11:00pm

Event Nature: Food trucks, entertainment, fireworks display  
Age of Event: 14th year  
Occurrence: Annually

Location/Venue: Memorial (Duck Pond) Park

Address: 160 East Blvd., Macclenny, FL 32063

Project Participants: 30 vendors  
Projected Attendance: 1,500-2,000  
Projected Overnight Stays: Unknown

The process to collect hotel data is: N/A

---

---

Requested amount of money from TDC:

Sponsorship Level (If Applicable):

\$15,000.00

REQUEST FOR FUNDING MUST INCLUDE FULL BUDGET FOR EVENT AS ATTACHMENT

Years of TDC Sponsorship:

4 years.

Other Sponsors listed:

### Audience Profile

Local: % 80

North Florida %: 20

% Age 0-5: 5

Florida %: \_\_\_\_\_

% Age 5-12: 5

Southeast %: \_\_\_\_\_

% Age 13-17: 5

National %: \_\_\_\_\_

% Age 18-24: 10

International %: \_\_\_\_\_

% Age 25-34: 15

% Age 35-44: 20

Target Groups: Ages 25-55

% Age 45-54: 20

% Age 55-64: 15

% Age 65+: 5

### Advertising and Promotion

The number of people who will directly or indirectly be informed of our sponsorship: 1,500 - 2,000 people.

Please describe your method to provide reach proof of performance: Estimated attendance.

Please list your advertising methods: Social media, Baker County Press, Radio stations, and local signage.

Does this event have a social media presence?

Facebook Baker County Chamber of Commerce

Instagram

Twitter

YouTube

Other \_\_\_\_\_

Site has Baker County TDC Logo? TDC will be recognized on all promotional materials and outlets.

Website: \_\_\_\_\_

If so, Where at? \_\_\_\_\_

Does this event have prelaunch activities? No.

Does this event have post event visibility? Yes. Follow-up on social media.

Location: Baker County Chamber of Commerce Facebook

Will Baker County be mentioned in public relations material? Yes.

**ALL PROMOTIONAL ITEMS AND ADVERTISEMENT MUST INCLUDE BAKER COUNTY SEAL AND THE FOLLOWING STATEMENT: "SPONSORED BY THE BAKER COUNTY TOURIST DEVELOPMENT COUNCIL".**

**Licensing, Video and Photo Rights**

---

Comments: \_\_\_\_\_

**Additional Comments**

---

\_\_\_\_\_  
\_\_\_\_\_  
\_\_\_\_\_

## 2026 Independence Day Celebration

Category	Line Item	Budget	Notes
Event Cost	Sound	\$6,500.00	Lighting, Sound, Entertainment
	Stage	\$2,500.00	
Advertisement	Radio Advertisement	\$2,800.00	
	Baker Co. Press	\$1,500.00	Half Page Ads x3
	Social Media	\$700.00	Facebook Targeted Ads
	Banners and Signs	\$500.00	
Other	Fireworks	\$10,000.00	
	Event Supplies	\$500.00	
<b>Total Event Budget</b>		<b>\$25,000.00</b>	
Total TDC Request		\$15,000.00	



## BAKER COUNTY BOARD OF COUNTY COMMISSIONERS

### AGENDA ITEM REQUEST FORM

The Board of County Commissioners meet on the 1<sup>st</sup> and 3<sup>rd</sup> Tuesday of each month at 5:00 p.m. at the Baker County Administration Office, Commission Chambers, 55 North Third Street, Macclenny, FL 32063. All agenda items should be submitted to County Administration via [sara.little@bakercountyfl.org](mailto:sara.little@bakercountyfl.org) and [kayla.riggs@bakercountyfl.org](mailto:kayla.riggs@bakercountyfl.org) no later than the Wednesday prior to the Commission meeting.

**Date of Submission:** April 2, 2026 **Meeting Date:** April 7, 2026

**Name of Submitter:** Kayla Riggs **Department:** TDC

1. Nature and purpose of this agenda item:

Christina Powell asked the TDC Board to use funds for advertising for the Spring Blooms Market event for Little Ladies Lemonade in the amount of \$1500.00. TDC approved on April 1, 2026 and staff recommends the approval of the use of TDC Funds be approved by BOCC.

2. Recommended Motion/Action:

approval of funding request for the use of TDC Funds.

3. Will this item require a presentation? No, Item backup document only.

4. Deadline for Completion: asap.

5. Fiscal Impact Questions:

Is this item included in the current budget? yes, TDC funds advertising for tourist events.

If item is grant related, is there a County match requirement? na

Explain the procurement process for this request (attach necessary documentation): The host of the event presents request to the TDC Board, once TDC approves the final recommendation is through the BOCC.

TDC approved \$1500.00 on 4/1/26  
Danny Norton motioned, Roger Lankford seconded the motion



## TOURIST DEVELOPMENT COUNCIL

### APPLICATION REQUIREMENTS

- All funding requests will be broken down into 2 payments. (80/20) 80% will be provided in advance upon approved application. Upon receipt of invoices that match funding request staff will release the final 20% payment.
- Receipts must match funds request. Any remaining funds must be returned to the County.
- Applicant(s) or a Representative must present funding request to TDC Board during meeting. Appearance via telephone is available for valid reason. If not present, request will not be discussed.
- Applications must be submitted to the TDC at least 3 days prior to the TDC meeting for review.

**By signing below applicant acknowledges receipt of application requirements.**

*CA Powell*

**Funding Request Application**

*03/06/2026*

**Date**



Requested amount of money from TDC:

\$ 1,500

Sponsorship Level (If Applicable):

**REQUEST FOR FUNDING MUST INCLUDE FULL BUDGET FOR EVENT AS ATTACHMENT**

Years of TDC Sponsorship:

Other Sponsors listed:

Audience Profile

Local: % 35%

North Florida %: 40%

Florida %: 15%

Southeast %: 8%

National %: 2%

International %: 0%

% Age 0-5: 8%

% Age 5-12: 12%

% Age 13-17: 8%

% Age 18-24: 10%

% Age 25-34: 18%

% Age 35-44: 18%

% Age 45-54: 14%

% Age 55-64: 8%

% Age 65+: 4%

Target Groups: Families, regional shoppers, craft & artisan market visitors, food enthusiasts, & tourists from surrounding N. FL & SE Georgia

Advertising and Promotion

The number of people who will directly or indirectly be informed of our sponsorship: 10,000-20,000

Please describe your method to provide reach proof of performance: 100 vendors sharing post alone could reach thousands. Social media analytics, FB event engagement, vendor cross-promotion, estim reach radio, signs, newsp.

Please list your advertising methods: Newspaper, radio, signs, online FB Event promotion, vendor social media <sup>cross</sup> promotion, & online community event calendars

Does this event have a social media presence?

Facebook yes

Instagram -

Twitter -

YouTube -

Other Community vendor market w/ regional advertising

Site has Baker County TDC Logo? Yes

Website: Facebook event page

If so, Where at? Event page, social media, promotional materials, & event signage

Does this event have prelaunch activities? Yes - social media promotion, vendor marketing, and regional advertising leading up to event

Does this event have post event visibility? Yes, social media posts, photos, and vendor follow-up sharing highlighting the event & Baker County

Location: Baker County Fairgrounds

Will Baker County be mentioned in public relations material? Yes, Baker County will be mentioned in promotional materials, advertising, and event marketing.

**ALL PROMOTIONAL ITEMS AND ADVERTISEMENT MUST INCLUDE BAKER COUNTY SEAL AND THE FOLLOWING STATEMENT: "SPONSORED BY THE BAKER COUNTY TOURIST DEVELOPMENT COUNCIL".**

#### Licensing, Video and Photo Rights

Comments: Event photos and video may be used for promotional purposes and to highlight tourism in Baker County.

#### Additional Comments

this event will feature approximately 100 vendors and is designed to attract visitors from surrounding counties and North Florida. Regional advertising and vendor promotion will encourage attendees to visit Baker County, supporting local businesses and tourism.

# Event Budget – Spring Market at the Baker County Fairgrounds

Location: Baker County Fairgrounds, Macclenny, FL

Projected Vendors: 100

Projected Attendance: 1,200–1,500

Event Expenses	Estimated Cost
Regional Radio Advertising	\$500
Newspaper Advertising	\$300
Roadside Signage / Banners	\$400
Social Media Advertising	\$200
Event Insurance	\$250
Marketing Materials (flyers, printing)	\$200
Miscellaneous Event Expenses	\$200
<b>Total Event Expenses</b>	<b>\$2,050</b>

Event Revenue	Amount
Vendor Booth Fees (100 vendors avg \$40)	\$4,000
Sponsorships	\$500
TDC Advertising Request	\$1,500
<b>Total Revenue</b>	<b>\$6,000</b>

**TDC Funding Request: \$1,500**

Funds will be used for regional advertising including radio, newspaper placements, roadside signage, and targeted social media promotion to attract visitors from surrounding counties and North Florida to Baker County.



TDC Approved \$8000.00 on 4/1/26  
Danny Norton motioned, Commissioner  
Hartley seconded.



## TOURIST DEVELOPMENT COUNCIL

### APPLICATION REQUIREMENTS

- All funding requests will be broken down into 2 payments. (80/20) 80% will be provided in advance upon approved application. Upon receipt of invoices that match funding request staff will release the final 20% payment.
- Receipts must match funds request. Any remaining funds must be returned to the County.
- Applicant(s) or a Representative must present funding request to TDC Board during meeting. Appearance via telephone is available for valid reason. If not present, request will not be discussed.
- Applications must be submitted to the TDC at least 3 days prior to the TDC meeting for review.

**By signing below applicant acknowledges receipt of application requirements.**

*Dillon C. Pullen*

\_\_\_\_\_  
**Funding Request Application**

February 17, 2026

\_\_\_\_\_  
**Date**



## Applicant

---

Business: \_\_\_\_\_ Non-Profit:  X  Individual: \_\_\_\_\_  
Baker County Chamber of Commerce

Contact: \_\_\_\_\_ Phone: \_\_\_\_\_ Email: \_\_\_\_\_  
Dillon C. Pullen (904) 259-6433 Dpullen@bakerchamberfl.com

Address: \_\_\_\_\_  
20 East Macclenny, Ave., Macclenny, Florida, 32063

Second Contact: \_\_\_\_\_  
\_\_\_\_\_

## Event Details

---

Event Name: \_\_\_\_\_ Start Date/Time: \_\_\_\_\_

Event Type: \_\_\_\_\_ End Date/Time: \_\_\_\_\_

Event Nature: \_\_\_\_\_ Age of Event: \_\_\_\_\_ Occurrence: \_\_\_\_\_

Location/Venue: \_\_\_\_\_  
\_\_\_\_\_

Address: \_\_\_\_\_  
\_\_\_\_\_

Project Participants: \_\_\_\_\_ Projected Attendance: \_\_\_\_\_ Projected Overnight Stays: \_\_\_\_\_

The process to collect hotel data is: \_\_\_\_\_  
\_\_\_\_\_  
\_\_\_\_\_

Requested amount of money from TDC:

Sponsorship Level (If Applicable):

\$8,000.00

**REQUEST FOR FUNDING MUST INCLUDE FULL BUDGET FOR EVENT AS ATTACHMENT**

Years of TDC Sponsorship:

Other Sponsors listed:

## Audience Profile

Local: % \_\_\_\_\_

North Florida %: \_\_\_\_\_

% Age 0-5: \_\_\_\_\_

Florida %: \_\_\_\_\_

% Age 5-12: \_\_\_\_\_

Southeast %: \_\_\_\_\_

% Age 13-17: \_\_\_\_\_

National %: \_\_\_\_\_

% Age 18-24: \_\_\_\_\_

International %: \_\_\_\_\_

% Age 25-34: \_\_\_\_\_

% Age 35-44: \_\_\_\_\_

Target Groups: \_\_\_\_\_

% Age 45-54: \_\_\_\_\_

% Age 55-64: \_\_\_\_\_

% Age 65+: \_\_\_\_\_

## Advertising and Promotion

The number of people who will directly or indirectly be informed of our sponsorship: \_\_\_\_\_

Please describe your method to provide reach proof of performance: \_\_\_\_\_

Please list your advertising methods: \_\_\_\_\_

Does this event have a social media presence?

Facebook \_\_\_\_\_

Instagram \_\_\_\_\_

Twitter \_\_\_\_\_

YouTube \_\_\_\_\_

Other \_\_\_\_\_

Site has Baker County TDC Logo? \_\_\_\_\_

Website: \_\_\_\_\_

If so, Where at? \_\_\_\_\_

Does this event have prelaunch activities? \_\_\_\_\_

Does this event have post event visibility? \_\_\_\_\_

Location: \_\_\_\_\_

Will Baker County be mentioned in public relations material? \_\_\_\_\_

**ALL PROMOTIONAL ITEMS AND ADVERTISEMENT MUST INCLUDE BAKER COUNTY SEAL AND THE FOLLOWING STATEMENT: "SPONSORED BY THE BAKER COUNTY TOURIST DEVELOPMENT COUNCIL".**

## Licensing, Video and Photo Rights

---

Comments: \_\_\_\_\_

## Additional Comments

---

Funding request is not event related. The Chamber is requesting funds to produce the 2026 - 2027 Discover Baker County Destination Guide. 3,000 copies of the guide will be initially printed for distribution. Tourism will be featured in 20 pages of the 28 page guide. TDC logo will be placed throughout the guide for maximum exposure.

---

## FEMA Pojects

Project	Awarded Company	BOCC Award Date	Status	Start Date	Completion Date	Cost
RFP 2025-06 23A Box Culvert	J.D. Hinson Co.	8/5/2025	Pending Obligation Notice to Proceed Issued			\$1,125,000.00
RFP 2025-07 Boat Ramp	Nordic Group/AMI	8/5/2025	Pending Obligation Notice to Proceed Issued			\$548,000.00
RFP 2025-10 Steel Bridge Road	J.B. Coxwell Cont.	8/5/2025	Pending Scope and Cost Development			\$1,798,759.23
RFP 2025-11 Turner Cemetery Bridge	Gulf Coast Underground, LLC	8/5/2025	Pending Scope and Cost Development Notice to Proceed Issued			\$827,570.00
RFP 2025-14 Shoals Park	TimPREP	1/20/2026	Pending EHP Review			\$497,857.00
Completed Project Countywide 61 Roads	Completed by County Staff	NA	Pending Obligation			

**Notes**

Only Partial FEMA Funding



Pending EHP Review

Pending Scope and Cost  
Development

Pending Scope and Cost  
Development

Pending EHP Review

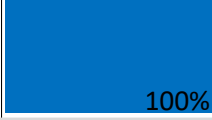
# Pending Business

PENDING BUSINESS ITEM	PRIORITY	STATUS	START DATE	% COMPLETE	COMMENTS
Infrastructure funding for County Roads	Normal	New	07/18/2017	 50%	Ongoing
St Marys Cove Boat Ramp Grant Phase 1	High	In Progress	01/01/2020	 100%	Project was completed but destroyed by Hurricane Debby before closeout was complete. FWC will require boat ramp reconstruction before final closeout is done.
St. Mary's Shoals Park Improvements	High	New	10/19/2021	 50%	Playground equipment purchase approval 4/7/2026
Cuyler Fire Station	High	New	01/03/2023	 90%	Waiting on Mobile home. Pending Grand Opening.
Knabb Sports Complex Appropriation Project	High	New	11/21/2023	95%	Phase 2 to begin June 15.
Courthouse Generator Appropriation Project	High	New	11/21/2023	60%	Equipment Installed. Switch being installed currently. Full building connected April 11. Will NOT require building shut down.
Sanderson Center	Normal	New	12/03/2024	0%	Work underway.
Community Development Permit Software	Normal	New		75%	See attached email from ADG

Bank Number: 1 / Name: First Federal / Description: Operating Account

Payment Number	Type	ID	Name	SRC	Num INV	Gross Amount	Discounts	Net Pay	Payment Date	HP Void	Batch
1907	EPAY	A	FSEBT-FLORIDA SHERIFFS EMPLOYE	4486	1	82,608.00	.00	82,608.00	03/13/2026		24275
			HEALTH 3.26	HEALTH11.24-042		82,608.00	0.00	82,608.00			
	DIST:		001-218101			79,276.00					
	DIST:		001-511-1100-52310			3,332.00					
989186	CHK	A	ALACHUA COUNTY BOARD OF COUNTY	14	1	11,909.92	.00	11,909.92	03/16/2026		24288
			ME Mar26	ME2026-31		11,909.92	0.00	11,909.92			
	DIST:		104-527-2400-53110			11,909.92					
989190	CHK	A	FLORIDA MUNICIPAL INSURANCE TR	1182	1	156,445.00	.00	156,445.00	03/16/2026		24288
			Q3 FY25-26 Comm Prop/Crime/Mar	2526-0024-Q3-2		156,445.00	0.00	156,445.00			
	DIST:		001-511-1100-54500			68,990.00					
	DIST:		001-511-1100-54500			900.00					
	DIST:		001-511-1100-54500			18,199.50					
	DIST:		001-511-1100-54500			9,615.75					
	DIST:		001-511-1100-54500			16,153.25					
	DIST:		001-511-1100-54500			42,586.50					
989199	CHK	A	TARBOX CONSULTING AND DESIGN I	484	3	8,655.50	.00	8,655.50	03/16/2026		24288
			Enterprise East Infrastructure	1743		6,483.00	0.00	6,483.00			
	DIST:		195-000-1950-56021			6,483.00					
			All In Strg/Otter Run/FPL-CD	1745		632.50	0.00	632.50			
	DIST:		001-524-2500-53100			27.50					
	DIST:		001-524-2500-53100			220.00					
	DIST:		001-524-2500-53100			385.00					
			All In Strg/Church of God/O-CD	1754		1,540.00	0.00	1,540.00			
	DIST:		001-524-2500-53100			220.00					
	DIST:		001-524-2500-53100			192.50					
	DIST:		001-524-2500-53100			660.00					
	DIST:		001-524-2500-53100			220.00					
	DIST:		001-524-2500-53100			137.50					
	DIST:		001-524-2500-53100			110.00					
989205	CHK	A		1062	1	5,447.51	.00	5,447.51	03/20/2026		24361
			HRA Reimbursement FY25-26	HRA2FY25-26		5,447.51	0.00	5,447.51			
	DIST:		110-511-1000-54910			5,447.51					
989213	CHK	A	L V HIERS INC	267	11	14,059.83	.00	14,059.83	03/20/2026		24361
			1066 gals dyed diesel/rd inv 0	196129		3,059.42	0.00	3,059.42			
	DIST:		103-541-5500-55211			3,059.42					
			Used Oil Pickup-Rd	196270		150.00	0.00	150.00			
	DIST:		103-541-5500-55210			150.00					
			hydraulic oil pump repair/rd i	196346		612.96	0.00	612.96			
	DIST:		103-541-5500-54600			612.96					
			1999 gals dyed diesel/rd inv 4	493011		6,096.96	0.00	6,096.96			
	DIST:		103-541-5500-55211			6,096.96					
			614 gals dyed diesel/rd inv 49	493035		1,872.70	0.00	1,872.70			
	DIST:		103-541-5500-55211			1,872.70					
			10Gal Hydraulic Oil-Rd	607865		80.00	0.00	80.00			
	DIST:		103-541-5500-55210			80.00					
			100 2.5 gals jugs blue DEF/rd	607924		1,200.00	0.00	1,200.00			
	DIST:		103-541-5500-55210			1,200.00					
			27.60Gal Fuel-Rd	607963		73.59	0.00	73.59			
	DIST:		103-541-5500-55211			73.59					
			123.40Gal Diesel/4Gal DEF-Rd	607966		416.96	0.00	416.96			
	DIST:		103-541-5500-55211			368.96					

Bank Number: 1 / Name: First Federal / Description: Operating Account

Payment Number	Type	ID	Name	SRC	Num INV	Gross Amount	Discounts	Net Pay	Payment Date	HP Void	Batch
	DIST:		103-541-5500-55210		48.00						
			106.30Gal Diesel-Rd	607974		317.84	0.00	317.84			
	DIST:		103-541-5500-55211		317.84						
			60Gal Diesel-Rd	607976		179.40	0.00	179.40			
	DIST:		103-541-5500-55211		179.40						
<b>989216</b>	<b>CHK</b>	<b>A</b>	<b>PRITCHETT TRUCKING INC</b>	<b>344</b>	<b>1</b>	<b>10,427.70</b>	<b>.00</b>	<b>10,427.70</b>	<b>03/20/2026</b>		<b>24361</b>
			20 loads limerock/rd inv 14627	146274		10,427.70	0.00	10,427.70			
	DIST:		103-541-5500-55300		10,427.70						
<b>989221</b>	<b>CHK</b>	<b>A</b>	<b>SCOTTY RHODEN, SHERIFF</b>	<b>757</b>	<b>1</b>	<b>18,587.07</b>	<b>.00</b>	<b>18,587.07</b>	<b>03/20/2026</b>		<b>24361</b>
			E911 12.25	3464		18,587.07	0.00	18,587.07			
	DIST:		104-521-2300-59123		1,887.62						
	DIST:		104-521-2300-59123		2,199.45						
	DIST:		104-521-2300-59123		8,234.28						
	DIST:		104-521-2300-59123		6,265.72						
<b>989223</b>	<b>CHK</b>	<b>A</b>	<b>SCOTTY RHODEN, SHERIFF</b>	<b>757</b>	<b>1</b>	<b>5,578.60</b>	<b>.00</b>	<b>5,578.60</b>	<b>03/20/2026</b>		<b>24361</b>
			EMPG Grant G0575 Claim #1	3468		5,578.60	0.00	5,578.60			
	DIST:		104-521-2300-58300		5,578.60						
<b>989236</b>	<b>CHK</b>	<b>A</b>	<b>FPL</b>	<b>200</b>	<b>20</b>	<b>12,346.21</b>	<b>.00</b>	<b>12,346.21</b>	<b>03/24/2026</b>		<b>24371</b>
			07521-58113 WOMEN SOFTBALL	07521-58113.1-132		182.26	0.00	182.26			
	DIST:		001-572-3300-54300		182.26						
			12567-18154 STREET LIGHTS	12567-18154-087		286.65	0.00	95.55			
	DIST:		001-537-2910-54301		11.94						
	DIST:		001-537-2910-54301		11.94						
	DIST:		103-541-5500-54301		11.94						
	DIST:		001-571-3200-54301		11.94						
	DIST:		001-524-2500-54301		11.94						
	DIST:		116-534-6500-54301		11.95						
	DIST:		001-537-2910-54301		11.95						
	DIST:		001-571-3200-54301		11.95						
			17019-59270 S50 GLEN FIRE	17019-59270-127		81.92	0.00	81.92			
	DIST:		105-522-5400-54301		81.92						
			17074-19774 PUBLIC DEFENDER	17074-19774.1-132		186.82	0.00	186.82			
	DIST:		001-603-1580-54301		186.82						
			47253-66092 COURTHOUSE	47253-66092.1-132		5,881.64	0.00	5,881.64			
	DIST:		001-712-2000-54301		5,881.64						
			50483-97334 TRANSP/WILLIS HODG	50483-97334.1-132		2,282.62	0.00	2,282.62			
	DIST:		001-564-3510-54307		973.78						
	DIST:		001-564-3510-54307		1,308.84						
			55706-76238 SENIOR LIFE CTR	55706-76238-048		715.86	0.00	715.86			
	DIST:		001-564-3510-54306		715.86						
			58599-18764 JEFF STARLING-SW	58599-18764.1-132		56.98	0.00	56.98			
	DIST:		116-534-6500-54301		56.98						
			65342-69524 ST50 SIGN	65342-69524.1-132		36.11	0.00	36.11			
	DIST:		105-522-5400-54301		36.11						
			80842-28439 SOFTBALL 480 6TH	80842-28439.1-132		135.70	0.00	135.70			
	DIST:		001-572-3300-54300		135.70						
			85105-19757 ADMIN BLDG 3RD ST	85105-19757.1-132		410.32	0.00	410.32			
	DIST:		001-511-1100-54301		410.32						
			85115-17784 CRT SERV/GAL	85115-17784.1-132		493.73	0.00	493.73			
	DIST:		001-564-3510-54305		197.49						
	DIST:		001-601-2210-54301		296.24						
			85125-13709 COM DEV 360E SHUEY	85125-13709.1-132		264.21	0.00	264.21			

Bank Number: 1 / Name: First Federal / Description: Operating Account

Payment Number	Type	ID	Name	SRC	Num INV	Gross Amount	Discounts	Net Pay	Payment Date	HP Void	Batch
			DIST: 001-524-2500-54301		264.21						
			85215-10746 COA US90	85215-10746.1-132		353.53	0.00	353.53			
			DIST: 001-564-3510-54306		353.53						
			85255-19743 COA US90	85255-19743.1-132		32.57	0.00	32.57			
			DIST: 001-564-3510-54306		32.57						
			85265-17779 LIBRARY 14 E MCIVE	85265-17779.1-132		912.67	0.00	912.67			
			DIST: 001-571-3200-54301		912.67						
			85285-11721 OLD JAIL 42W MCIVE	85285-11721.1-132		160.42	0.00	160.42			
			DIST: 001-572-3310-54300		160.42						
			90088-52551 OLUSTEE PARK LED	90088-52551.1-132		63.30	0.00	63.30			
			DIST: 001-572-3300-54300		63.30						
<b>989247</b>	<b>CHK</b>	<b>A</b>	<b>NAPA AUTO PARTS- JAX015</b>	<b>284</b>	<b>124</b>	<b>13,738.95</b>	<b>.00</b>	<b>13,738.95</b>	<b>03/24/2026</b>		<b>24371</b>
			#99 Oil/Air Filter-Rd	000053		31.98	0.00	31.98			
			DIST: 103-541-5500-54602		31.98						
			Gloves/Gauge/Chuck/Shop-Rd	000054		73.47	0.00	73.47			
			DIST: 103-541-5500-55210		73.47						
			T40 Coupling 7x/Adapter-Fire	000074		80.62	0.00	80.62			
			DIST: 105-522-5400-54602		80.62						
			T40 Coupling/Air Brake Ho-Fire	000086		22.78	0.00	22.78			
			DIST: 105-522-5400-54602		22.78						
			#99 Wiper Blade/Soap-Rd	000134		29.37	0.00	29.37			
			DIST: 103-541-5500-55210		2.69						
			DIST: 103-541-5500-54602		26.68						
			Welding Wire/Shop-Rd	000256		39.99	0.00	39.99			
			DIST: 103-541-5500-55210		39.99						
			Gloves/Lubricant-Rd	000340		49.48	0.00	49.48			
			DIST: 103-541-5500-55210		49.48						
			Threadlock/Silicone/Shop-Rd	000365		40.28	0.00	40.28			
			DIST: 103-541-5500-55210		40.28						
			#156 Clamp 12x/Battery-Rd	000397		241.29	0.00	241.29			
			DIST: 103-541-5500-54602		241.29						
			#99 Spark Plug Boot/Plug-Rd	000406		183.76	0.00	183.76			
			DIST: 103-541-5500-54602		183.76						
			#758 Adptr/Fittings/Hose/Ch-Rd	000408		305.36	0.00	305.36			
			DIST: 103-541-5500-54602		305.36						
			#2806 Fuel Filter 5x-Rd	000445		124.58	0.00	124.58			
			DIST: 103-541-5500-54602		124.58						
			#110 Hose Fittings/Hose-Rd	000488		246.69	0.00	246.69			
			DIST: 103-541-5500-54602		246.69						
			Utility Gloves 3pk-Rd	000489		10.99	0.00	10.99			
			DIST: 103-541-5500-55210		10.99						
			#97 Fuel/Oil Filter-Rd	000541		81.35	0.00	81.35			
			DIST: 103-541-5500-54602		81.35						
			air compressor for #99/rd inv	000543		3,000.00	0.00	3,000.00			
			DIST: 103-541-5500-55210		3,000.00						
			GMC Sierra Brk Shoe/Disc Pa-Rd	000651		126.64	0.00	126.64			
			DIST: 103-541-5500-54602		126.64						
			Utility Gloves 3pk/Gloves-Rd	000652		25.98	0.00	25.98			
			DIST: 103-541-5500-55210		25.98						
			#321 Hose/Fittings/Oring-Rd	000691		271.92	0.00	271.92			
			DIST: 103-541-5500-54602		271.92						
			GMC Sierra Brake Rotor/Shoe-Rd	000764		118.09	0.00	118.09			
			DIST: 103-541-5500-54602		118.09						
			6Ton Jack Stands/Sockets-Rd	000765		137.98	0.00	137.98			
			DIST: 103-541-5500-55210		137.98						

Bank Number: 1 / Name: First Federal / Description: Operating Account

Payment Number	Type	ID	Name	SRC	Num INV	Gross Amount	Discounts	Net Pay	Payment Date	HP Void	Batch
			#99 Bed Liner 2x-Rd		000766	140.98	0.00	140.98			
	DIST:		103-541-5500-54602			140.98					
			#97 Fuel Treatment-Rd		000838	14.29	0.00	14.29			
	DIST:		103-541-5500-54602			14.29					
			#97 Fuel Filter-Rd		000839	28.54	0.00	28.54			
	DIST:		103-541-5500-54602			28.54					
			Ratchet/Hexbit/Socket-Rd		000847	107.47	0.00	107.47			
	DIST:		103-541-5500-55210			107.47					
			#806 Batt Cbl Lug/Solenoid-Rd		000910	21.52	0.00	21.52			
	DIST:		103-541-5500-54602			21.52					
			UT1 Fuel Cap-Fire		000947	31.99	0.00	31.99			
	DIST:		105-522-5400-54602			31.99					
			Adapter/Tire Shop-Rd		000953	18.49	0.00	18.49			
	DIST:		103-541-5500-55210			18.49					
			#347 Battery/Battery Box-Rd		000965	198.59	0.00	198.59			
	DIST:		103-541-5500-54602			198.59					
			#805 Alternator-Rd		000985	159.95	0.00	159.95			
	DIST:		103-541-5500-54602			159.95					
			#2702 2.5 DEF-Rd		001161	38.98	0.00	38.98			
	DIST:		103-541-5500-54602			38.98					
			#99 Adptr/Connector/Coupler-Rd		001164	136.50	0.00	136.50			
	DIST:		103-541-5500-54602			136.50					
			HQ Silicone/Towels/Brush-EMS		001287	45.94	0.00	45.94			
	DIST:		001-526-2700-54600			12.58					
	DIST:		001-526-2700-55210			33.36					
			Antifreeze-AC		001326	10.06	0.00	10.06			
	DIST:		001-562-3400-54602			10.06					
			Bat2 Capsule-Fire		001753	16.99	0.00	16.99			
	DIST:		105-522-5400-54602			16.99					
			E20 Fittings/Hose/Adapter-Fire		001856	75.27	0.00	75.27			
	DIST:		105-522-5400-54602			75.27					
			T30 Wiper Motor-Fire		10522	134.03	0.00	134.03			
	DIST:		105-522-5400-54602			134.03					
			E70 Solenoid-Fire		10669	67.99	0.00	67.99			
	DIST:		105-522-5400-54602			67.99					
			UT1 Silicone/Terry Towels-Fire		10670	36.27	0.00	36.27			
	DIST:		105-522-5400-55210			19.29					
	DIST:		105-522-5400-54602			16.98					
			Cleaning Wipes/Brake Flui-Main		11374	24.98	0.00	24.98			
	DIST:		001-519-2100-55210			24.98					
			UT1 Bulb 2x-Fire		11785	4.58	0.00	4.58			
	DIST:		105-522-5400-54602			4.58					
			UT1 Super Glue-Fire		11786	3.29	0.00	3.29			
	DIST:		105-522-5400-54602			3.29					
			#8375 Hose Fittings/Hose-SW		1188	88.59	0.00	88.59			
	DIST:		116-534-6500-54602			88.59					
			GMC Sierra Wiper Blade 2x-Rd		1189	19.38	0.00	19.38			
	DIST:		103-541-5500-54602			19.38					
			UT1 2.5 DEF/Bug Clnr/Funn-Fire		12188	48.25	0.00	48.25			
	DIST:		105-522-5400-55210			2.29					
	DIST:		105-522-5400-54602			45.96					
			Transmission Fluid/Shop 3x-Rd		1283	119.97	0.00	119.97			
	DIST:		103-541-5500-55210			119.97					
			#5753 Oil Filter 2x-Rd		1484	15.98	0.00	15.98			
	DIST:		103-541-5500-54602			15.98					
			Lamp Gasket/Gloves/Shop-Rd		1485	52.81	0.00	52.81			

Bank Number: 1 / Name: First Federal / Description: Operating Account

Payment Number	Type	ID	Name	SRC	Num INV	Gross Amount	Discounts	Net Pay	Payment Date	HP Void	Batch
DIST:			103-541-5500-55210		52.81						
			#99 Hose/Batt Cable/Cbl Lug-Rd	1544		105.71	0.00	105.71			
DIST:			103-541-5500-54602		105.71						
			#79 Headlight Bulb-Rec	15759		9.39	0.00	9.39			
DIST:			001-572-3300-54602		9.39						
			#224 Brake Pads/Rotors-AC	15929		472.94	0.00	472.94			
DIST:			001-562-3400-54602		472.94						
			#5753 Oil Fil 5x/Air Fil 3x-Rd	16148		137.61	0.00	137.61			
DIST:			103-541-5500-54602		137.61						
			#5753 Oil Fil/Air Fil Retur-Rd	16184		37.99-	0.00	37.99-			
DIST:			103-541-5500-54602		37.99-						
			Tax Refund 16148-Rd	16262		9.00	0.00	9.00			
DIST:			103-541-5500-54602		9.00						
			#960 Hose Fitting 2x/Hose 2-SW	16265		70.30	0.00	70.30			
DIST:			116-534-6500-54602		70.30						
			Paint Marker/Locknut/Screw-Rd	1864		35.06	0.00	35.06			
DIST:			103-541-5500-55210		35.06						
			Chuck/Gauge/Gloves-Rd	1977		80.97	0.00	80.97			
DIST:			103-541-5500-55210		80.97						
			#2806 Fuel Filter/Oil Filte-Rd	1978		81.35	0.00	81.35			
DIST:			103-541-5500-54602		81.35						
			#156 Tees/Hose/Elbow/Connec-Rd	2029		91.76	0.00	91.76			
DIST:			103-541-5500-54602		91.76						
			#156 Water Pump-Rd	2078		119.99	0.00	119.99			
DIST:			103-541-5500-54602		119.99						
			#325 Battery Cable 42x-Rd	2079		185.18	0.00	185.18			
DIST:			103-541-5500-54602		185.18						
			#325 Chuck/Clamp-Rd	2122		45.48	0.00	45.48			
DIST:			103-541-5500-54602		45.48						
			E20 Hose Fitting/Hose-Fire	2124		64.94	0.00	64.94			
DIST:			105-522-5400-54602		64.94						
			#960 Transmission Fluid 3x-SW	2155		75.37	0.00	75.37			
DIST:			116-534-6500-54602		75.37						
			#943 Hose Fitting/Hose-SW	2163		253.23	0.00	253.23			
DIST:			116-534-6500-54602		253.23						
			WL1 Fuel Trtmt/Clamp/Filt-Fire	2165		14.47	0.00	14.47			
DIST:			105-522-5400-54602		14.47						
			#5753/347 Terminals/Chuck-Rd	2288		22.97	0.00	22.97			
DIST:			103-541-5500-54602		22.97						
			#125 Hose/Fittings/Absorben-SW	2292		228.32	0.00	228.32			
DIST:			116-534-6500-54602		228.32						
			Hose Fitting/Hose/Seal Tape-SW	23054		122.03	0.00	122.03			
DIST:			116-534-6500-54600		122.03						
			#943 Hose/Fittings-SW	2340		79.39	0.00	79.39			
DIST:			116-534-6500-54602		79.39						
			#14 Air Filter-Main	23742		29.71	0.00	29.71			
DIST:			001-519-2100-54602		29.71						
			Absorbent/Gloves/Coupler/Ch-Rd	2418		84.43	0.00	84.43			
DIST:			103-541-5500-55210		84.43						
			E50 Tubing 3x/Coupling 4x-Fire	2448		23.31	0.00	23.31			
DIST:			105-522-5400-54602		23.31						
			Screw/Nut/Lockwash-Shoal	25190		8.87	0.00	8.87			
DIST:			123-572-3920-54600		8.87						
			#817 Rear Brake Pads-SW	2546		44.32	0.00	44.32			
DIST:			116-534-6500-54602		44.32						
			#14 Brake Disc/Brake Pad-Main	25840		179.27	0.00	179.27			

Bank Number: 1 / Name: First Federal / Description: Operating Account

Payment Number	Type	ID	Name	SRC	Num INV	Gross Amount	Discounts	Net Pay	Payment Date	HP Void	Batch
DIST:			001-519-2100-54602		179.27						
			#115 Air Filter/Fuel Treat-Rd	2634		140.03	0.00	140.03			
DIST:			103-541-5500-54602		140.03						
			#115 Air Filter-Rd	2635		35.65	0.00	35.65			
DIST:			103-541-5500-54602		35.65						
			#753 Batt Protect/Sealer/Ba-Rd	2676		182.19	0.00	182.19			
DIST:			103-541-5500-54602		182.19						
			#753 Battery-Rd	2682		37.87	0.00	37.87			
DIST:			103-541-5500-54602		37.87						
			Battery-Rec	26839		53.08	0.00	53.08			
DIST:			001-572-3300-54602		53.08						
			SQ51 Thermostat/Antifreez-Fire	2694		31.97	0.00	31.97			
DIST:			105-522-5400-54602		31.97						
			#753 Fuse 4x-Rd	2699		14.76	0.00	14.76			
DIST:			103-541-5500-54602		14.76						
			SQ51 Connector 2x-Fire	27013		4.00	0.00	4.00			
DIST:			105-522-5400-54602		4.00						
			#5753 Battery-Rd	2702		138.12	0.00	138.12			
DIST:			103-541-5500-54602		138.12						
			#14 Brake Rotor-Main	27179		221.98	0.00	221.98			
DIST:			001-519-2100-54602		221.98						
			#14 Brake Rotor-Main	27229		3.99	0.00	3.99			
DIST:			001-519-2100-54602		225.97						
DIST:			001-519-2100-54602		221.98-						
			#14 Brake Pad Return-Main	27239		85.99-	0.00	85.99-			
DIST:			001-519-2100-54602		85.99-						
			#14 Brake Pad/Brake Clean-Main	27247		185.64	0.00	185.64			
DIST:			001-519-2100-54602		185.64						
			#817 Brake Disc 2x-SW	27254		128.98	0.00	128.98			
DIST:			116-534-6500-54602		128.98						
			Wash&Wax/Bleach/Armorall-Rec	27445		38.45	0.00	38.45			
DIST:			001-572-3300-55210		38.45						
			#102 Oil Filter/Trans Mount-Rd	27493		36.87	0.00	36.87			
DIST:			103-541-5500-54602		36.87						
			Sndrsn Compactor Fittings/H-SW	27565		307.76	0.00	307.76			
DIST:			116-534-6500-54600		307.76						
			#803 Battery-Rd	27566		209.49	0.00	209.49			
DIST:			103-541-5500-54602		209.49						
			#99 Impact Wrench/Adapter 4-Rd	2933		246.95	0.00	246.95			
DIST:			103-541-5500-54602		246.95						
			#7712 Oil/Air Filt/JB Weld-SW	33857		42.42	0.00	42.42			
DIST:			116-534-6500-54602		42.42						
			#806 Fuel Filter/Wiper Blad-Rd	33904		48.22	0.00	48.22			
DIST:			103-541-5500-54602		48.22						
			#102 Ignition Switch/HD Wip-Rd	34024		56.97	0.00	56.97			
DIST:			103-541-5500-54602		56.97						
			#2806 Capsule/Grease/Elec C-Rd	34046		83.44	0.00	83.44			
DIST:			103-541-5500-54602		83.44						
			#964 Oil/Adapter/Support-Rd	34075		68.97	0.00	68.97			
DIST:			103-541-5500-54602		68.97						
			#806 Fuel Filter/Air Filter-Rd	34851		144.20	0.00	144.20			
DIST:			103-541-5500-54602		144.20						
			#960 Air Chuck/Gauge-SW	34928		57.98	0.00	57.98			
DIST:			116-534-6500-54602		57.98						
			#49 1Qt 5W30 Oil 2x-Rec	46414		25.98	0.00	25.98			
DIST:			001-572-3300-54602		25.98						

Bank Number: 1 / Name: First Federal / Description: Operating Account

Payment Number	Type	ID	Name	SRC	Num INV	Gross Amount	Discounts	Net Pay	Payment Date	HP Void	Batch
			E50 Circuit Breaker-Fire		47525	64.99	0.00	64.99			
	DIST:		105-522-5400-54602			64.99					
			#142 Hose 2x/Clamp 20x-SW		5279	48.58	0.00	48.58			
	DIST:		116-534-6500-54602			48.58					
			#90 Fuel Filter 3x-Rd		5679	26.73	0.00	26.73			
	DIST:		103-541-5500-54602			26.73					
			E50 Hood Latch Kit-Fire		6685	58.99	0.00	58.99			
	DIST:		105-522-5400-54602			58.99					
			B30 Starter Button-Fire		6687	15.49	0.00	15.49			
	DIST:		105-522-5400-54602			15.49					
			B30 Solenoid-Fire		6690	16.22	0.00	16.22			
	DIST:		105-522-5400-54602			16.22					
			B30 Fuel Filter-Fire		6691	4.69	0.00	4.69			
	DIST:		105-522-5400-54602			4.69					
			BR70 Air Filter-Fire		9004	25.29	0.00	25.29			
	DIST:		105-522-5400-54602			25.29					
			E50 Air Filter 4x-Fire		9005	96.60	0.00	96.60			
	DIST:		105-522-5400-54602			96.60					
			T40 Wiper Motor-Fire		9173	134.03	0.00	134.03			
	DIST:		105-522-5400-54602			134.03					
			#953 Battery 2x-Rd		9213	478.98	0.00	478.98			
	DIST:		103-541-5500-54602			478.98					
			#817 Front Brake Pads-SW		9240	44.32	0.00	44.32			
	DIST:		116-534-6500-54602			44.32					
			#964 Front Brake Pads-Rd		9292	35.40	0.00	35.40			
	DIST:		103-541-5500-54602			35.40					
			#156 Wiper Blade 4x/Tune Up-Rd		9294	60.45	0.00	60.45			
	DIST:		103-541-5500-54602			60.45					
			#960 Env Hose/Hyd Hose-SW		9434	141.50	0.00	141.50			
	DIST:		116-534-6500-54602			141.50					
			Plasma Cutter Rpr-Rd		999810	90.86	0.00	90.86			
	DIST:		103-541-5500-55210			90.86					
			Battery Charger/Shop-Rd		999887	63.99	0.00	63.99			
	DIST:		103-541-5500-55210			63.99					
			#321 Apdtr/Fittings/Hose-Rd		999888	221.29	0.00	221.29			
	DIST:		103-541-5500-54602			221.29					
			#5753 Mini Bulbs/Coupler-Rd		999918	10.78	0.00	10.78			
	DIST:		103-541-5500-54602			10.78					
			#99 Coveralls/Welding Helme-Rd		999920	27.58	0.00	27.58			
	DIST:		103-541-5500-55210			27.58					
			#960 Grommet/Signal Light-Rd		999973	70.56	0.00	70.56			
	DIST:		103-541-5500-54602			70.56					
<b>989252</b>	<b>CHK</b>	<b>A</b>	<b>SCOTTY RHODEN, SHERIFF</b>	<b>757</b>	<b>1</b>	<b>200,252.45</b>	<b>.00</b>	<b>200,252.45</b>	<b>03/24/2026</b>		<b>24371</b>
			Inmate Medical FY23/24		3452	200,252.45	0.00	200,252.45			
	DIST:		104-523-7100-58114			200,252.45					
<b>989273</b>	<b>CHK</b>	<b>A</b>	<b>TARBOX CONSULTING AND DESIGN I</b>	<b>484</b>	<b>3</b>	<b>58,041.88</b>	<b>.00</b>	<b>58,041.88</b>	<b>03/26/2026</b>		<b>24406</b>
			Enterprise East Infrastructure		1740	18,381.00	0.00	18,381.00			
	DIST:		195-000-1950-56021			18,381.00					
			Enterprise East Infrastructure		1741	26,318.00	0.00	26,318.00			
	DIST:		195-000-1950-56021			26,318.00					
			Enterprise East Infrastructure		1744	13,342.88	0.00	13,342.88			
	DIST:		195-000-1950-56021			13,342.88					
<b>989277</b>	<b>CHK</b>	<b>A</b>	<b>CGC INC</b>	<b>4645</b>	<b>1</b>	<b>503,707.50</b>	<b>.00</b>	<b>503,707.50</b>	<b>03/30/2026</b>		<b>24412</b>

Bank Number: 1 / Name: First Federal / Description: Operating Account

Payment Number	Type	ID	Name	SRC	Num INV	Gross Amount	Discounts	Net Pay	Payment Date	HP Void	Batch
			Willis Hodges drainage improve	C-25-01		503,707.50	0.00	503,707.50			
	DIST:		600-541-7500-54604.8			503,707.50					
989280	CHK	A	L V HIERS INC	267	3	9,068.17	.00	9,068.17	03/30/2026		24412
			1840 gals dyed diesel/rd inv 1	196760		7,157.60	0.00	7,157.60			
	DIST:		103-541-5500-55211			7,157.60					
			223 gals reg gas/rd inv 493024	493024		610.27	0.00	610.27			
	DIST:		103-541-5500-55211			610.27					
			408 gals reg gas/rd inv 493224	493224		1,300.30	0.00	1,300.30			
	DIST:		103-541-5500-55211			1,300.30					
989286	CHK	A	QUALITY INTERNET SERVICES OF F	349	1	9,854.83	.00	9,854.83	03/30/2026		24412
			2nd litter cycle though 3/2/26	150646		9,854.83	0.00	9,854.83			
	DIST:		103-541-5500-54606			9,854.83					
989288	CHK	A	SOUTHEASTERN SERVICES INC	387	1	12,306.06	.00	12,306.06	03/30/2026		24412
			site attendants thr 2/22/26	128884		12,306.06	0.00	12,306.06			
	DIST:		116-534-6500-53150			12,306.06					
989293	CHK	A	BENNETT FIRE PRODUCTS CO INC	2329	1	28,007.92	.00	28,007.92	03/31/2026		24427
			7SETS GLOBE JACKETS,T-Fire,EMS	3477		28,007.92	0.00	28,007.92			
	DIST:		105-522-5400-56400			28,007.92					
989294	CHK	A	C SLAGTER CONSTRUCTION INC	839	1	5,800.00	.00	5,800.00	03/31/2026		24427
			Guardrail repair CR 125 N near	5686		5,800.00	0.00	5,800.00			
	DIST:		103-541-5500-55300			5,800.00					
989304	CHK	A	NEW RIVER SOLID WASTE ASSOCIAT	317	1	17,769.30	.00	17,769.30	03/31/2026		24427
			Feb 2026 BOCC Tipping /sw	FEB26BOCC		17,769.30	0.00	17,769.30			
	DIST:		116-534-6500-53403			17,769.30					
989307	CHK	A	PITMAN ENGINEERING LLC	4504	1	5,365.00	.00	5,365.00	03/31/2026		24427
			CR125 Bridge erosion rpr/de-Rd	26-02BAK02		5,365.00	0.00	5,365.00			
	DIST:		600-541-7500-54604.4			5,365.00					
989314	CHK	A	SOUTHEASTERN SERVICES INC	387	1	12,306.06	.00	12,306.06	03/31/2026		24427
			site attendants through 3/8	128888		12,306.06	0.00	12,306.06			
	DIST:		116-534-6500-53150			12,306.06					
REGISTER TOTALS Checks: 22 Voids: 0 180 1,202,283.46 0.00 1,202,283.46											

ARPA PHASE 1 & 2							
Phase		Description	Budgeted Amount	Expended Amount		Notes	
1		Building Construction Fund- Fire Rescue	\$246,877	\$246,877		Central Fire	
1		Emergency Services Communication Upgrade	\$300,000	893,069.05		Approved for Payment 7/15/2022	
1		Road Infrastructure Improvements = Reid Stafford & Millings	\$250,000	249,727		Millings Purchased, Reid Stafford awarded 6/2023	
						Elevator = 25,132, Library Reno = \$125,000; Sanderson Station Propane Tank \$10,000; Sanderson Station Signage \$5000, \$10,000 Vet Park Docks; Vet Park Power/FPL Costs \$14,000; \$15,800 Health Department Keyless Door Repair; \$1430 Jonesville Park Boundary Survey; \$ 6,040,2-factor Authentication Key - Microsoft; \$7525 Library AC, \$3,000 trees at Post Office, \$26,742 Sanderson Fire Pump; \$82.50 Tarbox work for Pond at Central County. <b>\$40,194 COA Change Order \$2,8,072 Courthouse Keyless Entry Emergency Doors; \$67,735 Sanderson FS to FPL; \$6,700 Sanderson FS to Hometown; \$32,150 Sanderson FS to Sprinklermatic; \$28,868 Courthouse Generator</b>	
1		Facilities Infrastructure Improvements = Library, Admin, CDD, Fairgrounds	766,223	567,726.00			
1		County Infrastructure Improvements = litter, overtime & lawn service	185,000	60,135			
1		Incentive Pay to Eligible Workers	\$488,750	488,750			
		<b>TOTAL</b>	<b>\$2,836,850</b>	<b>\$2,506,284</b>			
2	BOCC	Emergency Services Communication Phase 2	300,000	803,762.15		803,762.15 paid, 10% payment remaining	
2	Maint	Replacement Vehicle	35,000	47119		Purchased	
2	Ag Ctr	Replacement Tables	8,400	8,110.00		Purchased	
2	Ext	Replacement Laptop	1,000	1039		Purchased	
2	Vet Svcs	Vehicle	35,000	42,601		Purchased	
2	Rec	Replacement Vehicle	40,000	47,119		Purchased	
2	Rec	Park Equipment	50,000	51,005		Jonesville Fencing = 4,480, Bleachers = 26,019, Knabb Fence Repair and Material \$18,721, Jonesville Park Fence Replacement \$1785	
2	Rec	Demo 2-Story Announcers Booth	10,000	14,300		Muncy awarded 2/7	
2	Rec	Replacement Mower	13,000	16,067		Purchased	
2	Rec	Replacement Field Groomer	13,000	14,595.00		Purchased	
2	Rec	Knabb Sports Complex Improvements- APPROPRIATION MATCH FUND	305,000	308,417		\$6,681 survey; \$76,600 irrigation, \$4,800 hydroseeding; \$61,430 concrete sidewalks and dugout pads; Privacy Fence and Tree Removal at Knabb, \$8,000; Vet Park and Jonesville- Ground Cover, Border \$13,431, \$7,522 sand for volleyball courts 5/30; \$33,840 fill dirt; \$11,800 clay, \$14,493 sand; \$63,700 fencing	
2	DevOps		6681	10,680		*Currently charged to DevOps- needs to be moved to ARPA	
2	DevOps	Security Related	4,500	0		vuln scanning	
2	DevOps	Large Format Scanner	8,000	7,612		Scanner Purchased \$4641, \$2383 for laminator; Table \$528	
2	Fire	Sanderson Fire Station	600,000	600,000		Complete	
2	Fire	Cuyler Fire Station	250,000	64,119		bathroom, driveway, garage doors conversion	
2	Fire	Thermal Camera	10,000	13,650		Purchased	
2	Transport	Replacement Office Furniture	2,000	0			
2	Transport	Replacement Equipment	5,000	1725		3 - Lucas Chest Compression Mounts	
2	Rescue	Headquarters Reno= Paint and Flooring	50,000	29,400		Paint and Flooring Complete	
2	S'W	Replacement Compactor Unit	34,500	31,336		Purchased	
2	S'W	Replacement of Dumpsters - 40 yard	27,500	20,406		Purchased	
2	S'W	Replacement of Dumpsters - 20 Yard	18,000	28,150		Purchased	
2	S'W	Replacement of Collection Site Attendant Building	5,000	4,234		All have been replaced 04/29/2024	
2	S'W	Collection Site Improvements	55,000			\$6,6654 Sign Cutter; Computer Clint; gate at steel bridge collection sit	
2	S'W	Collection Site Security Cameras	10,000	7,541			
2	BCSO	Body Worn Cameras	99,681	99681		Purchased	
2	Court Fac.	Security Improvements	200,000	230,180		Elevator Update x 2 \$50,264, Key Card System \$179,916; New	
2	Em Mng.	Transfer Switch	30,000	20,000		Purchased	
2	Contingenc	Contingency	6,589	0			
		<b>TOTAL</b>	<b>2,836,850</b>	<b>2,522,908.15</b>			



**Baker County**  
**Community Development Department**  
**Planning ~ Permitting ~ Code Enforcement ~ Building ~ Outreach**

360 East Shuey Avenue  
Macclenny, Florida 32063  
Phone (904) 259-2403

**STAFF REPORT**

**DATE:** February 4, 2026  
**TO:** Baker County Land Planning Agency & Baker County Board of Commissioners  
**FROM:** LaDonna Combs, Director  
Community Development Department  
**RE:** **Ordinance No. 2026-01 SMALL SCALE LAND USE AMENDMENT  
Agriculture B (AG B) to Very Low Density Residential (VLDR)**

---

**BACKGROUND**

Kelvin & Louann Crews on behalf of Nutty Buddy LLC has submitted two (2) applications to the Baker County Community Development Department requesting a change in land use and zoning. The subject parcels are comprised of 5 +/- acres and are currently vacant. Said parcels being identified as parcel ID 02-3S-20-0000-0000-0682 and 02-3S-20-0000-0000-0681 (each containing 2.5 acres) and is located off of Hill Lane in Sanderson. This property is currently considered non-conforming. The applicant intends to bring the parcels into compliance with current standards in order to place a mobile home on each lot. The companion rezoning ordinance requests a change from AG 10 to RCMH 2.5.

**INTENT**

The subject parcel has a land use designation of Agriculture B (AG B) and a zoning district of Agriculture 10 (AG 10). The Applicant proposes a land use amendment (Ordinance 2026-01) from **AGRICULTURE B (AG B) TO VERY LOW DENSITY RESIDENTIAL (VLDR)** and a companion rezoning (Ordinance 2026-02) from **AGRICULTURE 10 (AG 10) TO RESIDENTIAL CONVENTIONAL MOBILE HOME 2.5 (RCMH 2.5)**.

The subject parcel is bound by the following land use designations and zoning districts:

- North: Medium Density Residential / Residential Conventional Mobile Home 0.5
- South: Agriculture B / Agriculture 10
- East: Agriculture B & VLDR / Agriculture 10 & RCMH 2.5
- West: Agriculture B & VLDR / Agriculture 10 & RCMH 1

## CURRENT LAND USE CATEGORY

### **Policy A.1.10.1 Agriculture**

#### **B. Agriculture Ag B**

The category Ag B is in transition because of development potential because of location. Ag B lands lie at the fringe of developing areas, along major transportation routes or are contained within an area characterized by numerous pockets of already developed parcels. Mining and Mineral Extraction (mining) activities are allowed provided that before commencement of construction such activities have a conceptual reclamation permit approved by Baker County and the Department of Environmental Protection (including activities in floodplains and wetland areas) and any required state and federal permits for wetland impacts and shall be managed in accordance with the provisions of the Conservation Element and the Land Development Regulations. Borrow pits and fishponds are allowed.

Ag B lands are intended to be used for small-scale agriculture activities such as cultivation of field crops, livestock, dairies, or other uses on a limited scale.

Ag B lands may be developed at a maximum density of one (1) dwelling unit per 5 acres.

## PROPOSED LAND USE CATEGORY

### **Policy A.1.10.2 Residential**

The residential land use category includes single family detached, single family attached, duplex, and multi-family housing. Parcels of land designated for residential land uses are intended to be used predominately for housing and should be protected from intrusion of land uses that are incompatible with residential density or intensity of use.

The following minimum criteria pertain to residential land use categories:

- All development must meet building codes and have either a County Department of Health approved well and septic tank installation or connection to central water/sewer facilities.
- Compliance with the Concurrency Management System is required before development will be permitted at the stated densities/intensities of use.
- **Very Low Density**  
Range of density from a maximum density of 1 dwelling unit per acre to a minimum of 1 unit per 7.5 acres, which will include zoning categories: Ag 7.5, RCMH1, RC1, and RCMH 2.5.

## **DEVELOPMENT REVIEW COMMITTEE COMMENTS**

The application was circulated to the DRC Members, and the following reflect their comments:

#### **Baker County Fire and Rescue / Trevor Nelson, Chief**

- Issues with access and road needs to be improved to support the weight of Fire Apparatus since it does not abut a currently maintained County Road.

#### **Environmental Health / Ryan McFadden**

- No issues.

#### **Public Works Department / Chris Lee, Director**

- No issues.

#### **School District / Chadd Scarborough**

- No comments.

County Manager / Sara Little

- No issues.

**RECOMMENDATION**

Staff recommends **APPROVAL** of the proposed Small Scale Land Use Amendment application for **Ordinance 2026-01** requesting change of **AGRICULTURE B (AG B)** to **VERY LOW DENSITY RESIDENTIAL (VLDR)**.

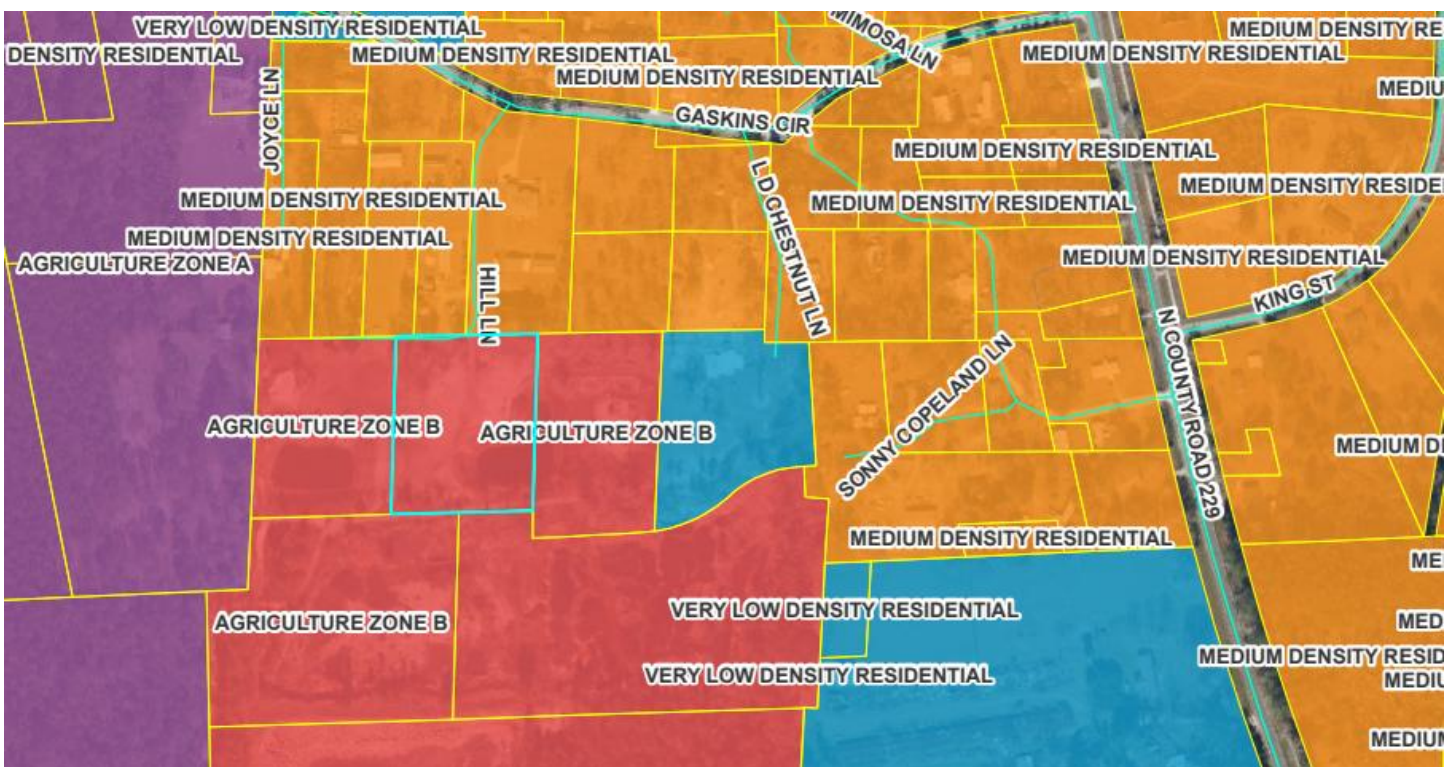
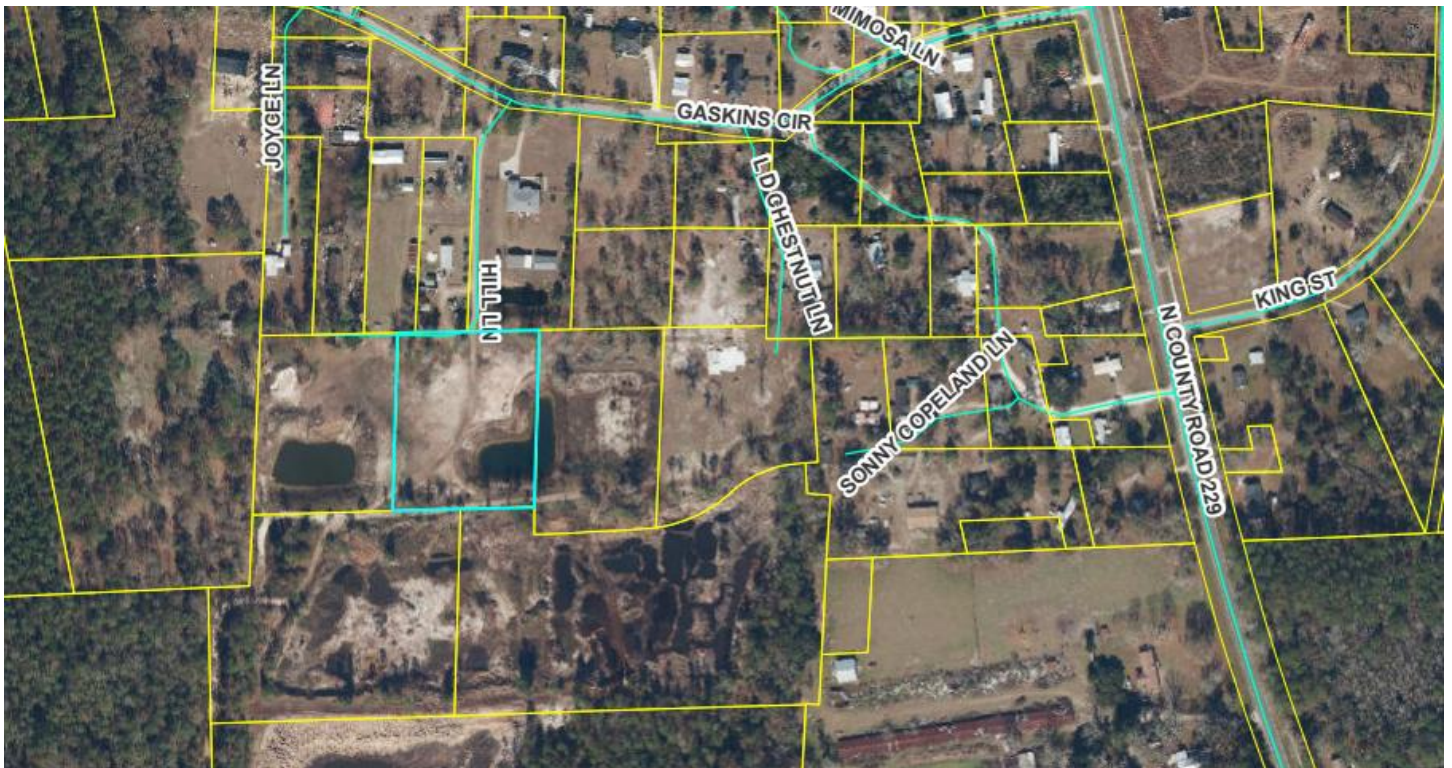

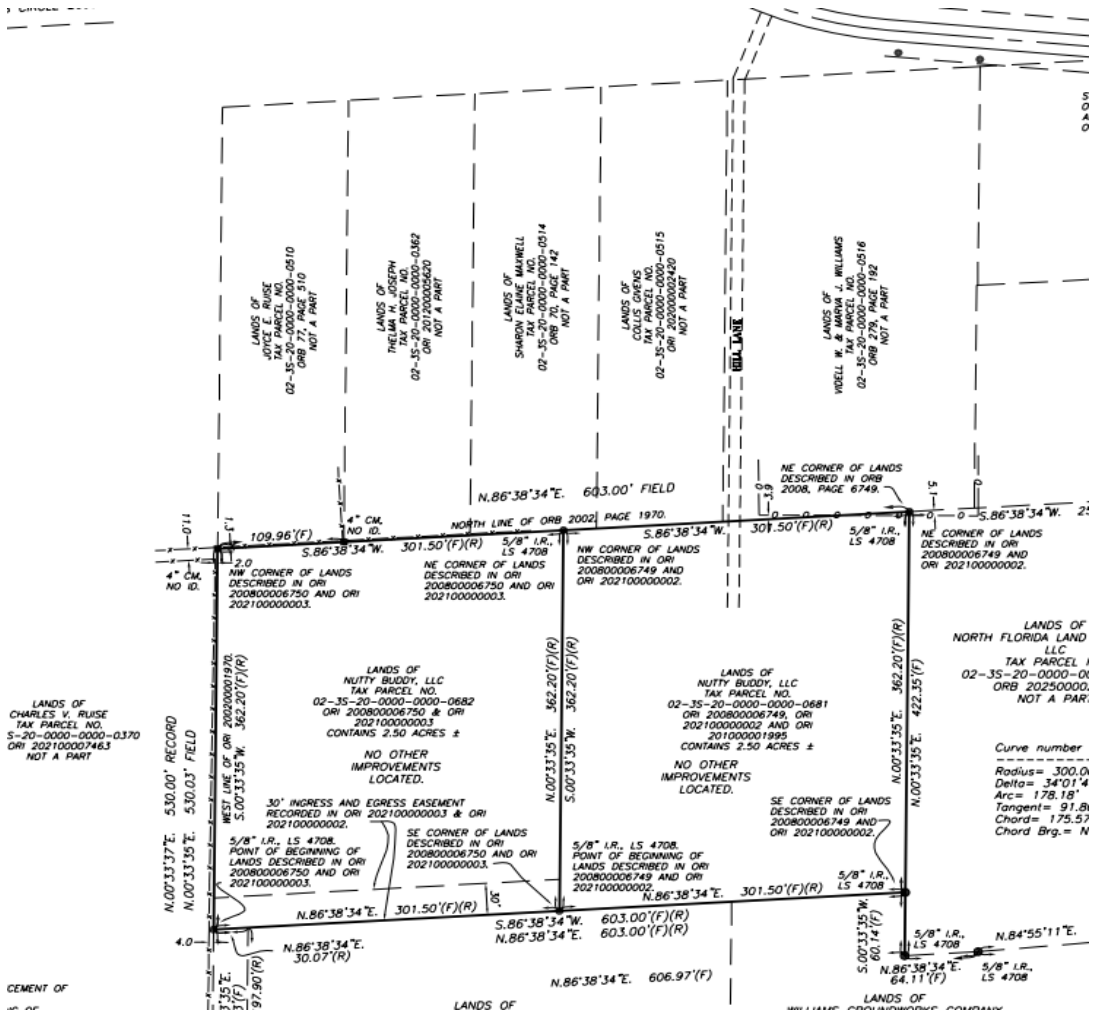
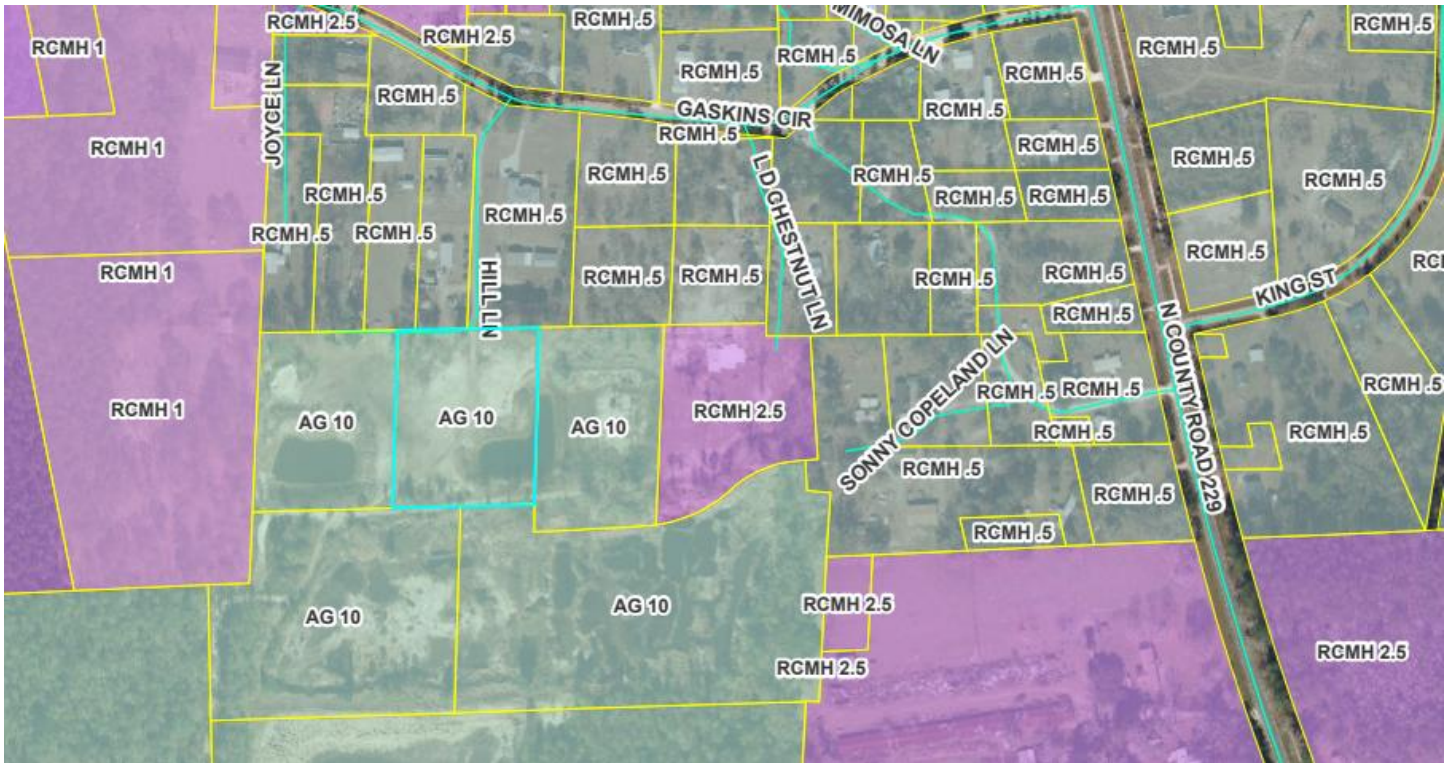

**ORDINANCE 2026-01**

**AN ORDINANCE OF THE BOARD OF COUNTY COMMISSIONERS OF BAKER COUNTY, FLORIDA MAKING A SMALL SCALE AMENDMENT TO THE BAKER COUNTY COMPREHENSIVE PLAN BY RECLASSIFYING APPROXIMATELY 5.00 +/- ACRES OF REAL PROPERTY OWNED BY NUTTY BUDDY LLC FROM AGRICULTURE B (AG B) TO VERY LOW DENSITY RESIDENTIAL (VLDR) IN ORDER TO BRING THE PARCEL INTO COMPLIANCE ON THE FUTURE LAND USE MAP; PROVIDING FINDINGS BY THE BOARD OF COUNTY COMMISSIONERS; PROVIDING DIRECTION FOR RECORDING; PROVIDING FOR SEVERABILITY; AND PROVIDING AN EFFECTIVE DATE.**

**WHEREAS**, the Community Planning Act; Section 163.3161 through 163.3215, Florida Statutes, require that each local government prepare and adopt a comprehensive land use plan, Zoning Map, and regulations; and

**WHEREAS**, Section 163.3184, Florida Statutes, requires that any amendment to the Baker County Comprehensive Plan or any element of portion thereof be made by ordinance; and

**WHEREAS**, the Board of County Commissioners of Baker County, Florida wishes to amend the Baker County Future Land Use Map; and

**WHEREAS**, the proposed small scale amendment to the Baker County Future Land Use Map is for approximately **5.00 +/-** acres of real property owned by **NUTTY BUDDY LLC**; and

**WHEREAS**, the corresponding parcel identification number is **02-3S-20-0000-0000-0681 AND 02-3S-20-0000-0000-0682**; and

**WHEREAS**, a duly advertised public hearing was conducted on **Tuesday, March 10, 2026 after 6:00 P.M.** by the Baker County Land Planning Agency (LPA); and the LPA provided its recommendations to the Board of County Commissioners of Baker County, Florida; and

**WHEREAS**, the Board of County Commissioners of Baker County, Florida held a duly advertised public hearing on **Tuesday, March 17, 2026 after 6:00 P.M.** for the purpose of hearing public comments; and

**WHEREAS**, the Board of County Commissioners of Baker County, Florida considered the recommendations of the LPA at the duly advertised public hearing held on **Tuesday, April 7, 2026 after 6:00 P.M.** and approved the amendment to the Baker County Future Land Use Map; and

**WHEREAS**, the Board of County Commissioners of Baker County, Florida finds that the adoption of this ordinance for the amendment to the Baker County Future Land Use Map, and the reclassification of real property described herein is consistent with the Goals, Objectives, and Policies of the Baker County Comprehensive Plan is in the best interest of Baker County, Florida and its citizens.

**NOW THEREFORE, BE IT ORDAINED** by the Board of County Commissioners of Baker County, Florida as follows:

Section 1. Adoption and Incorporation of Recitals. The Board of County Commissioners of Baker County, Florida hereby adopts the above recitals and incorporates them herein as a part of this ordinance.

Section 2. Ownership and Description of Property. The real property reclassified by this Ordinance is owned by **NUTTY BUDDY LLC** and identified by the Baker County Property Appraiser Identification Number: **02-3S-20-0000-0000-0681 AND 02-3S-20-0000-0000-0682**; and is more particularly described in “Exhibit 1” which is attached hereto and incorporated herein by reference.

Section 3. Purpose and Authority of Ordinance. This Ordinance is adopted for the purpose of allowing for an amendment to the Baker County Future Land Use Map.

Section 4. Reclassification of Property. The Board of County Commissioners of Baker County, Florida reclassifies the parcel of real property described in “Exhibit 1” from **AGRICULTURAL B (AG B) TO VERY LOW DENSITY RESIDENTIAL (VLDR)** on the Future Land Use Map of the Baker County Comprehensive Plan.

Section 5. Direction to Staff. Following approval by the Board of County Commissioners of Baker County, Florida, the staff of the Community Development Department is directed to file the same in the Official Records of Baker County, Florida.

Section 6. Recording of Ordinance. Following approval by the Board of County Commissioners of Baker County, Florida, the staff of the Clerk of the Court is directed to file the same in the Official Records of Baker County, Florida.

Section 7. Effective Date of Ordinance. This Ordinance shall become effective upon adoption by the Board of County Commissioners of Baker County, Florida.

**PASSED AND ADOPTED** with a quorum present and voting, by the Board of County Commission of Baker County, Florida, in regular session, this **Tuesday, April 7, 2026**.

**BOARD OF COUNTY COMMISSIONERS OF  
BAKER COUNTY, FLORIDA**

---

**RONALD MANN, CHAIR  
COUNTY COMMISSION**

**ATTEST:**

---

**STACIE HARVEY  
CLERK OF THE BOARD**

# EXHIBIT 1

DESCRIPTION: TAX PARCEL NO. 02-35-20-0000-0000-0682

PART OF THE SW ¼ OF THE SE ¼ OF SECTION 2, TOWNSHIP 3 SOUTH, RANGE 20 EAST, BAKER COUNTY, FLORIDA, MORE PARTICULARLY DESCRIBED AS FOLLOWS: COMMENCE AT THE SW CORNER OF THE SW ¼ OF THE SE ¼ OF SECTION 2, TOWNSHIP 3 SOUTH, RANGE 20 EAST, THENCE RUN N 86 DEGREES 39'14" E, A DISTANCE OF 88.04 FEET TO A CONCRETE MONUMENT LS 1380; THENCE RUN N 00 DEGREES 33'35" E, ALONG THE WEST LINE OF OFFICIAL RECORD BOOK (ORB) 2002, PAGE 1970 A DISTANCE OF 167.83 FEET TO A 5/8 INCH IRON ROD LS 4708 AND THE POINT OF BEGINNING; THENCE N 86 DEGREES 38'34" E, A DISTANCE OF 301.50 FEET; THENCE N 00 DEGREES 33'35" E, A DISTANCE OF 362.20 FEET TO THE NORTH LINE OF SAID LANDS DESCRIBED IN ORB 2002, PAGE 1970; THENCE S 86 DEGREES 38'34" W, ALONG THE NORTH LINE OF SAID LANDS A DISTANCE OF 301.50 FEET TO A CONCRETE MONUMENT MARKING THE NW CORNER OF SAID ORB 2002, PAGE 1970; THENCE S 00 DEGREES 33'35" W, ALONG THE AFOREMENTIONED WEST LINE A DISTANCE OF 362.20 FEET TO THE POINT OF BEGINNING, CONTAINING 2.50 ACRES, MORE OR LESS.

TOGETHER WITH A 30 FOOT EASEMENT FOR INGRESS AND EGRESS MORE PARTICULARLY DESCRIBED AS FOLLOWS: COMMENCE AT THE SW CORNER OF THE SW ¼ OF THE SE ¼ OF SECTION 2, TOWNSHIP 3 SOUTH, RANGE 20 EAST; THENCE RUN N 86 DEGREES 39'14" E, A DISTANCE OF 88.04 FEET TO A CONCRETE MONUMENT LS 1380; THENCE RUN N 00 DEGREES 33'35" E, ALONG THE WEST LINE OF OFFICIAL RECORDS BOOK (ORB) 2002, PAGE 1970 A DISTANCE OF 167.83 FEET TO A 5/8 INCH IRON ROD, LS 4708 AND THE POINT OF BEGINNING OF THE HEREIN DESCRIBED EASEMENT; THENCE RUN N 86 DEGREES 38'34" E, A DISTANCE OF 301.50 FEET TO THE SW CORNER OF THE ABOVE DESCRIBED LANDS; THENCE RUN N 00 DEGREES 33'35" E, A DISTANCE OF 30.00 FEET; THENCE RUN S 86 DEGREES 38'34" W, A DISTANCE OF 301.50 FEET; THENCE RUN S 00 DEGREES 33'35" W, A DISTANCE OF 30.00 FEET TO THE POINT OF BEGINNING.

TOGETHER WITH A 30 FOOT EASEMENT FOR INGRESS AND EGRESS BEING A PART OF THE SW ¼ OF THE SE ¼ OF SECTION 2, AND ALSO A PART OF THE NW ¼ OF THE NE ¼ OF SECTION 11, ALL BEING IN TOWNSHIP 3 SOUTH, RANGE 20 EAST, BAKER COUNTY, FLORIDA, MORE PARTICULARLY DESCRIBED AS FOLLOWS: BEGIN AT THE SW CORNER OF THE NW ¼ OF THE NE ¼ OF SECTION 11, TOWNSHIP 3 SOUTH, RANGE 20 EAST, AND RUN N 00 DEGREES 02'25" E, ALONG THE WEST LINE OF SAID NW ¼ OF THE NE ¼, ALSO BEING THE EAST LINE OF CITRUS ACRES, AS RECORDED IN PLAT BOOK 1, PAGE 9 OF THE PUBLIC RECORDS OF BAKER COUNTY, FLORIDA, A DISTANCE OF 1346.17 FEET TO A CONCRETE MONUMENT LS 1380 MARKING THE SW CORNER OF THE SW ¼ OF THE SE ¼ OF SECTION 2 AND ALSO BEING A POINT ON THE NORTH LINE OF SAID NW ¼ OF THE NE ¼ OF SECTION 11; THENCE N 86 DEGREES 39'14" E, ALONG SAID NORTH LINE OF SECTION 11, A DISTANCE OF 88.04 FEET TO THE SW CORNER OF PARCEL 136, DESCRIBED IN OFFICIAL RECORDS BOOK (ORB) 2002, PAGE 1970 BAKER COUNTY, FLORIDA; THENCE N 00 DEGREES 33'35" E ALONG THE WEST LINE OF SAID PARCEL 136, A DISTANCE OF 167.83 FEET TO A 5/8 INCH IRON ROD, LS 4708; THENCE N 86 DEGREES 38'34" E, A DISTANCE OF 30.07 FEET; THENCE S 00 DEGREES 33'35" W, PARALLEL TO THE WEST LINE OF SAID PARCEL 136, A DISTANCE OF 197.90 FEET; THENCE S 86 DEGREES 39'14" W, PARALLEL TO SAID NORTH LINE OF SECTION 11, A DISTANCE OF 87.78 FEET; THENCE S 00 DEGREES 02'25" W, PARALLEL TO SAID WEST LINE OF SAID NW ¼ OF THE NE ¼ OF SECTION 11, A DISTANCE OF 1316.08 FEET TO THE SOUTH LINE OF SAID NW ¼ OF THE NE ¼; THENCE S 86 DEGREES 34'35" W, ALONG SAID SOUTH LINE OF THE NW ¼ OF THE NE ¼, A DISTANCE OF 30.05 FEET TO THE POINT OF BEGINNING.

TOGETHER WITH AN EASEMENT FOR INGRESS AND EGRESS BEING MORE PARTICULARLY DESCRIBED AS FOLLOWS: THE SOUTH 60 FEET OF THE NORTH ¼ OF THE NW ¼ OF SECTION 11 (ALSO BEING THE SOUTH 60 FEET OF CITRUS ACRES AS RECORDED IN PLAT BOOK 1 PAGE 9 OF THE PUBLIC RECORDS OF BAKER COUNTY, FLORIDA); THE WEST 30 FEET OF THE NORTH ¼ OF THE NW ¼ OF SECTION 11; THE EAST 30 FEET OF THE NORTH ¼ OF THE NE ¼ OF SECTION 10; THE WEST 30 FEET OF THE SW ¼ OF SECTION 2, LYING SOUTH OF GUNTER ROAD (A COUNTY MAINTAINED GRADED ROAD); THE EAST 30 FEET OF THE SE ¼ OF SECTION 3, LYING SOUTH OF GUNTER ROAD (A COUNTY MAINTAINED GRADED ROAD); THENCE SOUTHEASTERLY 30 FEET EITHER SIDE OF THE CENTER OF SAID GUNTER ROAD, 2600 FEET, MORE OR LESS, TO THE INTERSECTION WITH THE WESTERLY RIGHT OF WAY OF GASKINS CIRCLE (A 60 FOOT RIGHT OF WAY AS NOW ESTABLISHED) IN TOWNSHIP 2 SOUTH, RANGE 20 EAST, BAKER COUNTY, FLORIDA.

DESCRIPTION: TAX PARCEL NO. 02-35-20-0000-0000-0681

PART OF THE SW ¼ OF THE SE ¼ OF SECTION 2, TOWNSHIP 3 SOUTH, RANGE 20 EAST, BAKER COUNTY, FLORIDA, MORE PARTICULARLY DESCRIBED AS FOLLOWS: COMMENCE AT THE SW CORNER OF THE SW ¼ OF THE SE ¼ OF SECTION 2, TOWNSHIP 3 SOUTH, RANGE 20 EAST, THENCE RUN N 86 DEGREES 39'14" E, A DISTANCE OF 88.04 FEET TO A CONCRETE MONUMENT LS 1380; THENCE RUN N 00 DEGREES 33'35" E, ALONG THE WEST LINE OF OFFICIAL RECORD BOOK (ORB) 2002, PAGE 1970 A DISTANCE OF 167.83 FEET TO A 5/8 INCH IRON ROD LS 4708; THENCE RUN N 86 DEGREES 38'34" E, A DISTANCE OF 301.50 FEET TO THE POINT OF BEGINNING; THENCE N 00 DEGREES 33'35" E, A DISTANCE OF 362.20 FEET TO THE NORTH LINE OF SAID LANDS DESCRIBED IN ORB 2002, PAGE 1970; THENCE N 86 DEGREES 38'34" E, ALONG THE NORTH LINE OF SAID LANDS A DISTANCE OF 301.50 FEET TO A 5/8 INCH IRON ROD LS 4708; THENCE S 00 DEGREES 33'35" W, A DISTANCE OF 362.20 FEET TO 5/8 INCH IRON ROD LS 4708; THENCE S 86 DEGREES 38'34" W, A DISTANCE OF 301.50 FEET TO THE POINT OF BEGINNING, CONTAINING 2.50 ACRES, MORE OR LESS.

TOGETHER WITH A 30 FOOT EASEMENT FOR INGRESS AND EGRESS MORE PARTICULARLY DESCRIBED AS FOLLOWS: COMMENCE AT THE SW CORNER OF THE SW ¼ OF THE SE ¼ OF SECTION 2, TOWNSHIP 3 SOUTH, RANGE 20 EAST; THENCE RUN N 86 DEGREES 39'14" E, A DISTANCE OF 88.04 FEET TO A CONCRETE MONUMENT LS 1380; THENCE RUN N 00 DEGREES 33'35" E, ALONG THE WEST LINE OF OFFICIAL RECORDS BOOK (ORB) 2002, PAGE 1970 A DISTANCE OF 167.83 FEET TO A 5/8 INCH IRON ROD, LS 4708 AND THE POINT OF BEGINNING OF THE HEREIN DESCRIBED EASEMENT; THENCE RUN N 86 DEGREES 38'34" E, A DISTANCE OF 301.50 FEET TO THE SW CORNER OF THE ABOVE DESCRIBED LANDS; THENCE RUN N 00 DEGREES 33'35" E, A DISTANCE OF 30.00 FEET; THENCE RUN S 86 DEGREES 38'34" W, A DISTANCE OF 301.50 FEET; THENCE RUN S 00 DEGREES 33'35" W, A DISTANCE OF 30.00 FEET TO THE POINT OF BEGINNING.

TOGETHER WITH A 30 FOOT EASEMENT FOR INGRESS AND EGRESS BEING A PART OF THE SW ¼ OF THE SE ¼ OF SECTION 2, AND ALSO A PART OF THE NW ¼ OF THE NE ¼ OF SECTION 11, ALL BEING IN TOWNSHIP 3 SOUTH, RANGE 20 EAST, BAKER COUNTY, FLORIDA, MORE PARTICULARLY DESCRIBED AS FOLLOWS: BEGIN AT THE SW CORNER OF THE NW ¼ OF THE NE ¼ OF SECTION 11, TOWNSHIP 3 SOUTH, RANGE 20 EAST, AND RUN N 00 DEGREES 02'25" E, ALONG THE WEST LINE OF SAID NW ¼ OF THE NE ¼, ALSO BEING THE EAST LINE OF CITRUS ACRES, AS RECORDED IN PLAT BOOK 1, PAGE 9 OF THE PUBLIC RECORDS OF BAKER COUNTY, FLORIDA, A DISTANCE OF 1346.17 FEET TO A CONCRETE MONUMENT LS 1380 MARKING THE SW CORNER OF THE SW ¼ OF THE SE ¼ OF SECTION 2 AND ALSO BEING A POINT ON THE NORTH LINE OF SAID NW ¼ OF THE NE ¼ OF SECTION 11; THENCE N 86 DEGREES 39'14" E, ALONG SAID NORTH LINE OF SECTION 11, A DISTANCE OF 88.04 FEET TO THE SW CORNER OF PARCEL 136, DESCRIBED IN OFFICIAL RECORDS BOOK (ORB) 2002, PAGE 1970 BAKER COUNTY, FLORIDA; THENCE N 00 DEGREES 33'35" E ALONG THE WEST LINE OF SAID PARCEL 136, A DISTANCE OF 167.83 FEET TO A 5/8 INCH IRON ROD, LS 4708; THENCE N 86 DEGREES 38'34" E, A DISTANCE OF 30.07 FEET; THENCE S 00 DEGREES 33'35" W, PARALLEL TO THE WEST LINE OF SAID PARCEL 136, A DISTANCE OF 197.90 FEET; THENCE S 86 DEGREES 39'14" W, PARALLEL TO SAID NORTH LINE OF SECTION 11, A DISTANCE OF 87.78 FEET; THENCE S 00 DEGREES 02'25" W, PARALLEL TO SAID WEST LINE OF SAID NW ¼ OF THE NE ¼ OF SECTION 11, A DISTANCE OF 1316.08 FEET TO THE SOUTH LINE OF SAID NW ¼ OF THE NE ¼; THENCE S 86 DEGREES 34'35" W, ALONG SAID SOUTH LINE OF THE NW ¼ OF THE NE ¼, A DISTANCE OF 30.05 FEET TO THE POINT OF BEGINNING.

TOGETHER WITH AN EASEMENT FOR INGRESS AND EGRESS BEING MORE PARTICULARLY DESCRIBED AS FOLLOWS: THE SOUTH 60 FEET OF THE NORTH ¼ OF THE NW ¼ OF SECTION 11 (ALSO BEING THE SOUTH 60 FEET OF CITRUS ACRES AS RECORDED IN PLAT BOOK 1 PAGE 9 OF THE PUBLIC RECORDS OF BAKER COUNTY, FLORIDA); THE WEST 30 FEET OF THE NORTH ¼ OF THE NW ¼ OF SECTION 11; THE EAST 30 FEET OF THE NORTH ¼ OF THE NE ¼ OF SECTION 10; THE WEST 30 FEET OF THE SW ¼ OF SECTION 2, LYING SOUTH OF GUNTER ROAD (A COUNTY MAINTAINED GRADED ROAD); THE EAST 30 FEET OF THE SE ¼ OF SECTION 3, LYING SOUTH OF GUNTER ROAD (A COUNTY MAINTAINED GRADED ROAD); THENCE SOUTHEASTERLY 30 FEET EITHER SIDE OF THE CENTER OF SAID GUNTER ROAD, 2600 FEET, MORE OR LESS, TO THE INTERSECTION WITH THE WESTERLY RIGHT OF WAY OF GASKINS CIRCLE (A 60 FOOT RIGHT OF WAY AS NOW ESTABLISHED) IN TOWNSHIP 2 SOUTH, RANGE 20 EAST, BAKER COUNTY, FLORIDA.



**Baker County**  
**Community Development Department**  
**Planning ~ Permitting ~ Code Enforcement ~ Building ~ Outreach**

360 East Shuey Avenue  
Macclenny, Florida 32063  
Phone (904) 259-2403  
Fax (904) 259-5057

**STAFF REPORT**

**DATE:** February 4, 2026  
**TO:** Baker County Land Planning Agency & Baker County Board of Commissioners  
**FROM:** LaDonna Combs, Director  
Community Development Department  
**RE:** **Ordinance No. 2026-02 REZONING**  
**Agriculture 10 (AG 10) to Residential Conventional Mobile Home 2.5 (RCMH2.5)**

---

**BACKGROUND**

Kelvin & Louann Crews on behalf of Nutty Buddy LLC has submitted two (2) applications to the Baker County Community Development Department requesting a change in land use and zoning. The subject parcels are comprised of 5 +/- acres and are currently vacant. Said parcels being identified as parcel ID 02-3S-20-0000-0000-0682 and 02-3S-20-0000-0000-0681 (each containing 2.5 acres) and is located off of Hill Lane in Sanderson. This property is currently considered non-conforming. The applicant intends to bring the parcels into compliance with current standards in order to place a mobile home on each lot. The companion land use application requests a change from Agriculture B to Very Low Density Residential.

**INTENT**

The subject parcel has a land use designation of Agriculture B (AG B) and a zoning district of Agriculture 7.5 (AG 7.5). The Applicant proposes a zoning change (Ordinance 2026-02) from **AGRICULTURE 10 (AG 10) TO RESIDENTIAL CONVENTIONAL MOBILE HOME 2.5 (RCMH 2.5)** and a companion land use amendment (Ordinance 2026-01) from **AGRICULTURE B (AG B) TO VERY LOW DENSITY RESIDENTIAL (VLDR)**.

The subject parcel is bound by the following land use designations and zoning districts:

North: Medium Density Residential / Residential Conventional Mobile Home 0.5

South: Agriculture B / Agriculture 10

East: Agriculture B & VLDR / Agriculture 10 & RCMH 2.5

West: Agriculture B & VLDR / Agriculture 10 & RCMH 1

## ORDINANCE CODE

The applicant requests to amend the Zoning Map by changing the current zoning. The following are relevant land development regulations from the Baker County Ordinance Code:

### CURRENT ZONING DISTRICT

#### **Sec. 24-190. - AG 10 Agricultural District.**

- (a) *Generally.* This section applies to the AG 10 Agricultural District. This district is similar to the AG 20 district; however, the minimum lot size is ten acres. Development must meet building codes and have a county department of health approved well and septic tank installation. It applies to parcels under one ownership which are less than 320 acres at the time of adoption of the comprehensive plan and which are used for cultivation of silviculture crops, row crops and/or livestock within the Agricultural A land use category of the comprehensive plan. Accessory uses and special uses are also permitted.
- (b) *Permitted uses and structures.*
- (1) Within any AG 10 district, permitted uses and structures allowed by right are as follows:
    - a. Church.
    - b. Farming.
    - c. Feed lot (site plan review).
    - d. Feed store (site plan review).
    - e. Fishponds (two acres or less).
    - f. Golf course/club.
    - g. Guest house (site plan review).
    - h. Labor camp (site plan review).
    - i. Mobile home (one unit per ten acres).
    - j. Public or private riding stable (see section 24-148(c) and (d)).
    - k. Roadside produce stand.
    - l. Sawmill.
    - m. Silviculture.
    - n. Single-family (one unit per ten acres).
    - o. Slaughterhouse (site plan review).
    - p. Special use (see section 24-234).
    - q. Sports club.
    - r. Temporary use (see section 24-234).
    - s. Veterinary clinic (site plan review).
    - t. Borrow pits with a surface area totaling less than ten acres in size which meet the requirements of section 24-161.
  - (2) Additionally, within any AG 10 district the following accessory uses and structures are allowed:
    - a. Storage buildings, sheds, tool houses and private garages.
    - b. Noncommercial greenhouses and plant nurseries.
    - c. Play equipment.
    - d. Household pets.
    - e. Swimming pools.
- (c) *Permissible uses by special exception.*
- (1) Kennel.
  - (2) Homestead division.
  - (3) Family lot division.
  - (4) Fishponds (greater than two acres).
  - (5) Reserved.
  - (6) Wireless telecommunication facilities (see section 24-235).
  - (7) Semi-public uses.
    - a. Club.
    - b. Lodge.
    - c. Recreational association.

- d. Neighborhood association.
- e. Cultural activities.
- (8) Borrow pits with a surface area totaling less than ten acres in size which meet the requirements of section 24-161.
- (d) *Permissible use by mine permit.*
- (1) Excavation, mining and mineral extraction (see section 24-159; on ten acres or more).
- (e) *Permissible uses by limited notice.*
- (1) Day care center.
- (2) Home occupation.
- (f) *Setback and other standards.*
- (1) Minimum lot requirements (width, depth and area).
  - a. Width: 200 feet.
  - b. Depth: none.
  - c. Area: ten acres.
- (2) Maximum lot coverage by all buildings and structures.
  - a. Not applicable.
- (3) Minimum yard requirements.
  - a. Front: 50 feet.
  - b. Side: 30 feet.
  - c. Rear: 50 feet.
- (4) Maximum height of structures. Maximum height of structures shall be 50 feet.

## PROPOSED ZONING DISTRICT

### **Section 24-192. Residential Conventional and Mobile Home 2.5 District.**

- (a) *Generally.* The provisions of this section apply to the RCMH 2.5 Residential Conventional and Mobile Home District. The purpose of classifying land and water areas within this district is to provide a transition between agriculture and residential uses and to accommodate large lot residential development of single-family conventional and mobile homes within the Very Low Density land use category of the comprehensive plan. One unit per 2½ acres will be permitted. Development must meet building codes and have a county department of health approved well and septic tank installation. Accessory uses and special uses are also permitted.
- (b) *Permitted uses and structures.*
- (1) Within any RCMH 2.5 district, permitted uses and structures allowed by right are as follows:
  - a. Church.
  - b. Community residential facility, Type A.
  - c. Country club.
  - d. Fishponds (two acres or less).
  - e. Golf course/club.
  - f. Guest house (site plan review).
  - g. Reserved.
  - h. Mobile home (one unit per 2.5 acres).
  - i. Roadside produce stand.
  - j. Silviculture.
  - k. Single-family conventional (one unit per 2.5 acres).
  - l. Special use (see section 24-234).
  - m. Temporary use (see section 24-234).
- (2) Additionally, within any RCMH 2.5 district the following accessory uses and structures are allowed:
  - a. Storage buildings, sheds, tool houses and private garages.
  - b. Noncommercial greenhouses and plant nurseries.
  - c. Play equipment.
  - d. Household pets.
  - e. Swimming pools.
- (c) *Permissible uses by special exception.*

- (1) Private riding stable (site plan review; see section 24-148(c)).
- (2) Public riding stable (site plan review; see section 24-148(d)).
- (3) Veterinarian clinic (site plan review).
- (4) Wireless telecommunication facilities (see section 24-235).
- (5) Semi-public uses.
  - a. Club.
  - b. Lodge.
  - c. Recreational association.
  - d. Neighborhood association.
  - e. Cultural activities.
- (d) *Permissible uses by limited notice.*
  - (1) Day care center.
  - (2) Home occupation.
- (e) *Setback and other standards.*
  - (1) Minimum lot requirements (width, depth and area).
    - a. Width: 200 feet.
    - b. Area: 2.5 acres.
    - c. Depth: 300 feet.
  - (2) Maximum lot coverage by all buildings and structures.
    - a. Not applicable.
  - (3) Minimum yard requirements.
    - a. Front: 50 feet.
    - b. Side: 30 feet.
    - c. Rear: 50 feet.
  - (4) Maximum height of structures. Maximum height of structures shall be 45 feet.

**DEVELOPMENT REVIEW COMMITTEE COMMENTS**

The application was circulated to the DRC Members, and the following reflect their comments:

Baker County Fire and Rescue / Trevor Nelson

- 1. Issues with access and road needs to be improved to support the weight of Fire Apparatus since it does not abut a currently maintained County Road.

Public Works Department / Chris Lee

- 1. No issues.

Baker County Health Department / Ryan McFadden

- 1. No issues.

Baker County School District / Chadd Scarborough

- 1. No comments.

County Manager / Sara Little

- 1. No issues.

**RECOMMENDATION**

Staff recommends **APPROVAL** of the proposed Rezoning application for **Ordinance 2026-02** from **AGRICULTURE 10 (AG 10)** to **RESIDENTIAL CONVENTIONAL MOBILE HOME 2.5 (RCMH 2.5)**.

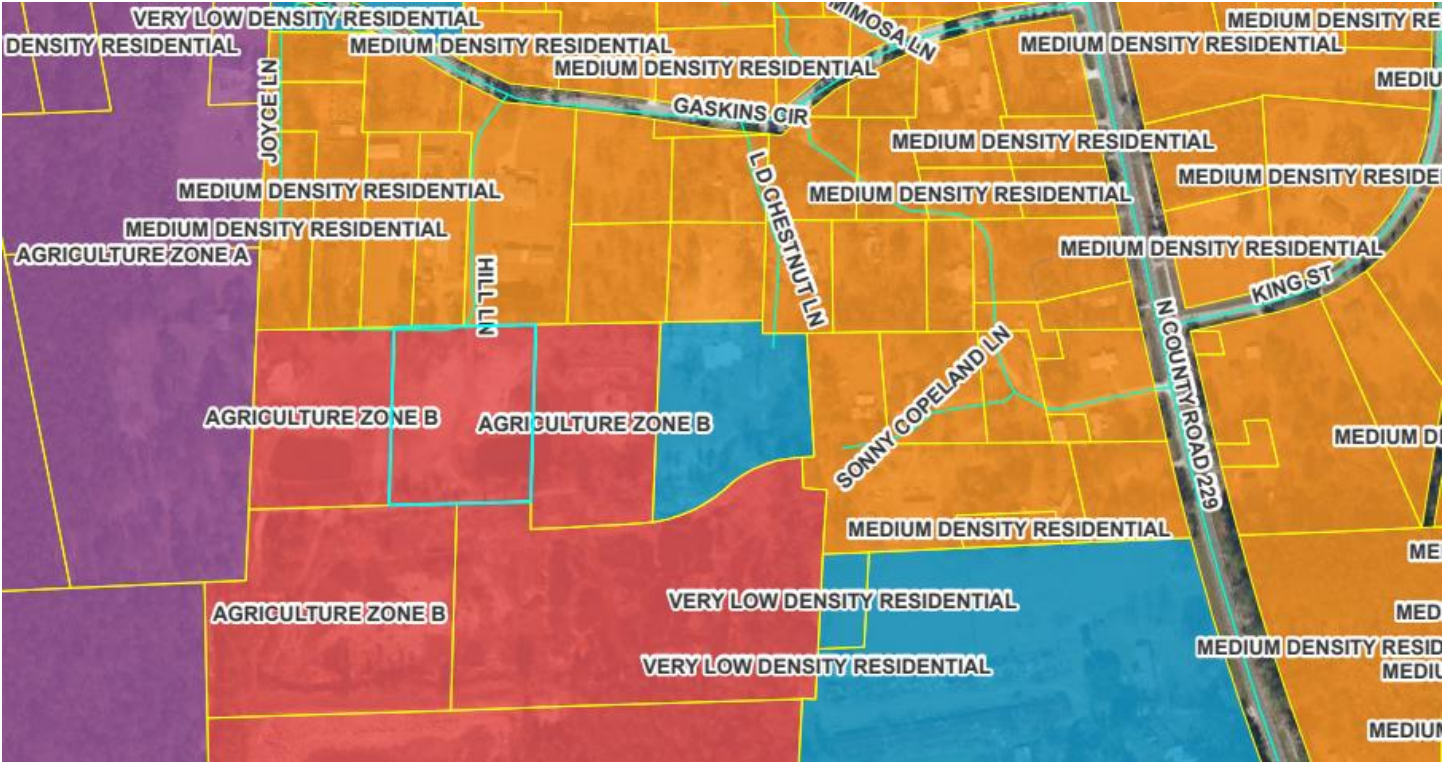
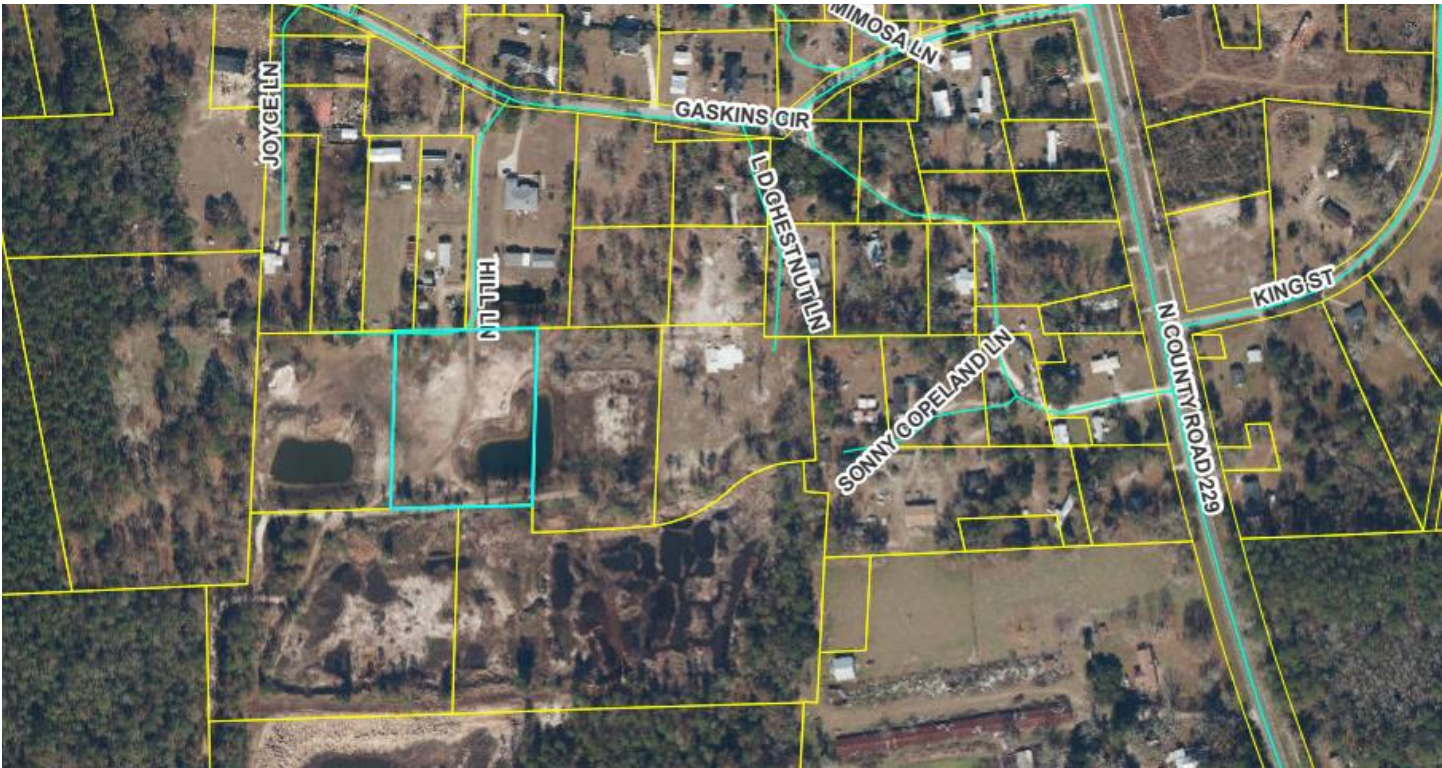



**ORDINANCE 2026-02**

**AN ORDINANCE OF THE BOARD OF COUNTY COMMISSIONERS OF BAKER COUNTY, FLORIDA AMENDING THE BAKER COUNTY ZONING MAP BY RECLASSIFYING APPROXIMATELY 5.00 +/- ACRES OF REAL PROPERTY OWNED BY NUTTY BUDDY LLC FROM AGRICULTURE 7.5 (AG 7.5) TO RESIDENTIAL CONVENTIONAL AND MOBILE HOME 2.5 (RCMH 2.5) WITH THE INTENT OF BRINGING THE PARCEL INTO COMPLIANCE WITH ITS ACREAGE; PROVIDING FOR A CHANGE OF ZONING; PROVIDING DIRECTIONS FOR RECORDING; PROVIDING FOR SEVERABILITY; AND PROVIDING AN EFFECTIVE DATE.**

**WHEREAS**, the Community Planning Act; Section 163.3161 through 163.3215, Florida Statutes, require that each local government prepare and adopt a comprehensive land use plan, Zoning Map, and regulations; and

**WHEREAS**, the Board of County Commissioners of Baker County, Florida wishes to amend the Baker County Zoning Map; and

**WHEREAS**, the proposed zoning change is for approximately **5.00 +/- acres** of real property owned by **NUTTY BUDDY LLC**; and

**WHEREAS**, the corresponding parcel identification number is **02-3S-20-0000-0000-0681 AND 02-3S-20-0000-0000-0682**; and

**WHEREAS**, a duly advertised public hearing was conducted on **Tuesday, March 10, 2026 after 6:00 P.M.** by the Baker County Land Planning Agency (LPA); and the LPA provided its recommendations to the Board of County Commissioners of Baker County, Florida; and

**WHEREAS**, the Board of County Commissioners of Baker County, Florida held a duly advertised public hearing on **Tuesday, March 17, 2026 after 6:00 P.M.** for the purpose of hearing public comments; and

**WHEREAS**, the Board of County Commissioners of Baker County, Florida considered the recommendations of the LPA at the duly advertised public hearing held on **Tuesday, April 7, 2026 after 6:00 P.M.** and approved the Rezoning; and

**WHEREAS**, the Board of County Commissioners of Baker County, Florida finds that the adoption of this ordinance for the Rezoning, the amendment to the Baker County Zoning Map, and the reclassification of real property described herein is consistent with the Goals, Objectives, and

Policies of the Baker County Comprehensive Plan and the Land Development Regulations of the Baker County Ordinance Code and is in the best interest of Baker County, Florida and its citizens.

**NOW THEREFORE, BE IT ORDAINED** by the Board of County Commissioners of Baker County, Florida as follows:

Section 1. Adoption and Incorporation of Recitals. The Board of County Commissioners of Baker County, Florida hereby adopts the above recitals and incorporates them herein as a part of this ordinance.

Section 2. Ownership and Description of Property. The real property reclassified by this Ordinance is owned by **NUTTY BUDDY LLC** and identified by the Baker County Property Appraiser Identification Number: **02-3S-20-0000-0000-0681 AND 02-3S-20-0000-0000-0682;** and is more particularly described in “Exhibit 1” which is attached hereto and incorporated herein by reference.

Section 3. Purpose and Authority of Ordinance. This Ordinance is adopted for the purpose of rezoning the above described real property pursuant to chapter 24 of the Baker County Land Development Regulations.

Section 4. Direction to Staff. Following approval by the Board of County Commissioners of Baker County, Florida, the staff of the Community Development Department is directed to file the same in the Official Records of Baker County, Florida.

Section 5. Recording of Ordinance. Following approval by the Board of County Commissioners of Baker County, Florida, the staff of the Clerk of the Court is directed to file the same in the Official Records of Baker County, Florida.

Section 6. Effective Date of Ordinance. This Ordinance shall become effective upon adoption by the Board of County Commissioners of Baker County, Florida.

**PASSED AND ADOPTED** with a quorum present and voting, by the Board of County Commission of Baker County, Florida, in regular session, this **Tuesday, April 7, 2026**.

**BOARD OF COUNTY COMMISSIONERS OF  
BAKER COUNTY, FLORIDA**

---

**RONALD MANN, CHAIR  
COUNTY COMMISSION**

**ATTEST:**

---

**STACIE HARVEY  
CLERK OF THE BOARD**

# EXHIBIT 1

DESCRIPTION: TAX PARCEL NO. 02-35-20-0000-0000-0682

PART OF THE SW ¼ OF THE SE ¼ OF SECTION 2, TOWNSHIP 3 SOUTH, RANGE 20 EAST, BAKER COUNTY, FLORIDA, MORE PARTICULARLY DESCRIBED AS FOLLOWS: COMMENCE AT THE SW CORNER OF THE SW ¼ OF THE SE ¼ OF SECTION 2, TOWNSHIP 3 SOUTH, RANGE 20 EAST, THENCE RUN N 86 DEGREES 39'14" E, A DISTANCE OF 88.04 FEET TO A CONCRETE MONUMENT LS 1380; THENCE RUN N 00 DEGREES 33'35" E, ALONG THE WEST LINE OF OFFICIAL RECORD BOOK (ORB) 2002, PAGE 1970 A DISTANCE OF 167.83 FEET TO A 5/8 INCH IRON ROD LS 4708 AND THE POINT OF BEGINNING; THENCE N 86 DEGREES 38'34" E, A DISTANCE OF 301.50 FEET; THENCE N 00°03'35" E, A DISTANCE OF 362.20 FEET TO THE NORTH LINE OF SAID LANDS DESCRIBED IN ORB 2002, PAGE 1970; THENCE S 86 DEGREES 38'34" W ALONG THE NORTH LINE OF SAID LANDS A DISTANCE OF 301.50 FEET TO A CONCRETE MONUMENT MARKING THE NW CORNER OF SAID ORB 2002, PAGE 1970; THENCE S 00 DEGREES 33'35" W, ALONG THE FOREMENTIONED WEST LINE A DISTANCE OF 362.20 FEET TO THE POINT OF BEGINNING. CONTAINING 2.50 ACRES, MORE OR LESS.

TOGETHER WITH A 30 FOOT EASEMENT FOR INGRESS AND EGRESS MORE PARTICULARLY DESCRIBED AS FOLLOWS: COMMENCE AT THE SW CORNER OF THE SW ¼ OF THE SE ¼ OF SECTION 2, TOWNSHIP 3 SOUTH, RANGE 20 EAST; THENCE RUN N 86 DEGREES 39'14" E, A DISTANCE OF 88.04 FEET TO A CONCRETE MONUMENT LS 1380; THENCE RUN N 00 DEGREES 33'35" E, ALONG THE WEST LINE OF OFFICIAL RECORDS BOOK (ORB) 2002, PAGE 1970 A DISTANCE OF 167.83 FEET TO A 5/8 INCH IRON ROD, LS 4708 AND THE POINT OF BEGINNING OF THE HEREIN DESCRIBED EASEMENT; THENCE RUN N 86 DEGREES 38'34" E, A DISTANCE OF 301.50 FEET TO THE SW CORNER OF THE ABOVE DESCRIBED LANDS; THENCE RUN N 00 DEGREES 33'35" E, A DISTANCE OF 30.00 FEET; THENCE RUN S 86 DEGREES 38'34" W, A DISTANCE OF 301.50 FEET; THENCE RUN S 00 DEGREES 33'35" W, A DISTANCE OF 30.00 FEET TO THE POINT OF BEGINNING.

TOGETHER WITH A 30 FOOT EASEMENT FOR INGRESS AND EGRESS BEING A PART OF THE SW ¼ OF THE SE ¼ OF SECTION 2, AND ALSO A PART OF THE NW ¼ OF THE NE ¼ OF SECTION 11, ALL BEING IN TOWNSHIP 3 SOUTH, RANGE 20 EAST, BAKER COUNTY, FLORIDA, MORE PARTICULARLY DESCRIBED AS FOLLOWS: BEGIN AT THE SW CORNER OF THE NW ¼ OF THE NE ¼ OF SECTION 11, TOWNSHIP 3 SOUTH, RANGE 20 EAST, AND RUN N 00 DEGREES 02'25" E, ALONG THE WEST LINE OF SAID NW ¼ OF THE NE ¼, ALSO BEING THE EAST LINE OF CITRUS ACRES, AS RECORDED IN PLAT BOOK 1, PAGE 9 OF THE PUBLIC RECORDS OF BAKER COUNTY, FLORIDA, A DISTANCE OF 1346.17 FEET TO A CONCRETE MONUMENT LS 1380 MARKING THE SW CORNER OF THE SW ¼ OF THE SE ¼ OF SECTION 2 AND ALSO BEING A POINT ON THE NORTH LINE OF SAID NW ¼ OF THE NE ¼ OF SECTION 11; THENCE N 86 DEGREES 39'14" E, ALONG SAID NORTH LINE OF SECTION 11, A DISTANCE OF 88.04 FEET TO THE SW CORNER OF PARCEL 136, DESCRIBED IN OFFICIAL RECORDS BOOK (ORB) 2002, PAGE 1970 BAKER COUNTY, FLORIDA; THENCE N 00 DEGREES 33'35" E ALONG THE WEST LINE OF SAID PARCEL 136, A DISTANCE OF 167.83 FEET TO A 5/8 INCH IRON ROD, LS 4708; THENCE N 86 DEGREES 38'34" E, A DISTANCE OF 30.07 FEET; THENCE S 00 DEGREES 33'35" W, PARALLEL TO THE WEST LINE OF SAID PARCEL 136, A DISTANCE OF 197.90 FEET; THENCE S 86 DEGREES 39'14" W, PARALLEL TO SAID NORTH LINE OF SECTION 11, A DISTANCE OF 87.78 FEET; THENCE S 00 DEGREES 02'25" W, PARALLEL TO SAID WEST LINE OF SAID NW ¼ OF THE NE ¼ OF SECTION 11, A DISTANCE OF 1316.08 FEET TO THE SOUTH LINE OF SAID NW ¼ OF THE NE ¼; THENCE S 86 DEGREES 34'35" W, ALONG SAID SOUTH LINE OF THE NW ¼ OF THE NE ¼, A DISTANCE OF 30.05 FEET TO THE POINT OF BEGINNING.

TOGETHER WITH AN EASEMENT FOR INGRESS AND EGRESS BEING MORE PARTICULARLY DESCRIBED AS FOLLOWS: THE SOUTH 60 FEET OF THE NORTH ½ OF THE NW ¼ OF SECTION 11 (ALSO BEING THE SOUTH 60 FEET OF CITRUS ACRES AS RECORDED IN PLAT BOOK 1 PAGE 9 OF THE PUBLIC RECORDS OF BAKER COUNTY, FLORIDA); THE WEST 30 FEET OF THE NORTH ½ OF THE NW ¼ OF SECTION 11; THE EAST 30 FEET OF THE NORTH ½ OF THE NE ¼ OF SECTION 10; THE WEST 30 FEET OF THE SW ¼ OF SECTION 2, LYING SOUTH OF GUNTER ROAD (A COUNTY MAINTAINED GRADED ROAD); THE EAST 30 FEET OF THE SE ¼ OF SECTION 3, LYING SOUTH OF GUNTER ROAD (A COUNTY MAINTAINED GRADED ROAD). THENCE SOUTHEASTERLY 30 FEET EITHER SIDE OF THE CENTER OF SAID GUNTER ROAD, 2600 FEET, MORE OR LESS, TO THE INTERSECTION WITH THE WESTERLY RIGHT OF WAY OF GASKINS CIRCLE (A 60 FOOT RIGHT OF WAY AS NOW ESTABLISHED) IN TOWNSHIP 2 SOUTH, RANGE 20 EAST, BAKER COUNTY, FLORIDA.

DESCRIPTION: TAX PARCEL NO. 02-35-20-0000-0000-0681

PART OF THE SW ¼ OF THE SE ¼ OF SECTION 2, TOWNSHIP 3 SOUTH, RANGE 20 EAST, BAKER COUNTY, FLORIDA, MORE PARTICULARLY DESCRIBED AS FOLLOWS: COMMENCE AT THE SW CORNER OF THE SW ¼ OF THE SE ¼ OF SECTION 2, TOWNSHIP 3 SOUTH, RANGE 20 EAST, THENCE RUN N 86 DEGREES 39'14" E, A DISTANCE OF 88.04 FEET TO A CONCRETE MONUMENT LS 1380; THENCE RUN N 00 DEGREES 33'35" E, ALONG THE WEST LINE OF OFFICIAL RECORD BOOK (ORB) 2002, PAGE 1970 A DISTANCE OF 167.83 FEET TO A 5/8 INCH IRON ROD LS 4708; THENCE RUN N 86 DEGREES 38'34" E, A DISTANCE OF 301.50 FEET TO THE POINT OF BEGINNING; THENCE N 00 DEGREES 33'35" E, A DISTANCE OF 362.20 FEET TO THE NORTH LINE OF SAID LANDS DESCRIBED IN ORB 2002, PAGE 1970; THENCE N 86 DEGREES 38'34" E, ALONG THE NORTH LINE OF SAID LANDS A DISTANCE OF 301.50 FEET TO A 5/8 INCH IRON ROD LS 4708; THENCE S 00 DEGREES 33'35" W, A DISTANCE OF 362.20 FEET TO 5/8 INCH IRON ROD LS 4708; THENCE S 86 DEGREES 38'34" W, A DISTANCE OF 301.50 FEET TO THE POINT OF BEGINNING. CONTAINING 2.50 ACRES, MORE OR LESS.

TOGETHER WITH A 30 FOOT EASEMENT FOR INGRESS AND EGRESS MORE PARTICULARLY DESCRIBED AS FOLLOWS: COMMENCE AT THE SW CORNER OF THE SW ¼ OF THE SE ¼ OF SECTION 2, TOWNSHIP 3 SOUTH, RANGE 20 EAST; THENCE RUN N 86 DEGREES 39'14" E, A DISTANCE OF 88.04 FEET TO A CONCRETE MONUMENT LS 1380; THENCE RUN N 00 DEGREES 33'35" E, ALONG THE WEST LINE OF OFFICIAL RECORDS BOOK (ORB) 2002, PAGE 1970 A DISTANCE OF 167.83 FEET TO A 5/8 INCH IRON ROD, LS 4708 AND THE POINT OF BEGINNING OF THE HEREIN DESCRIBED EASEMENT; THENCE RUN N 86 DEGREES 38'34" E, A DISTANCE OF 301.50 FEET TO THE SW CORNER OF THE ABOVE DESCRIBED LANDS; THENCE RUN N 00 DEGREES 33'35" E, A DISTANCE OF 30.00 FEET; THENCE RUN S 86 DEGREES 38'34" W, A DISTANCE OF 301.50 FEET; THENCE RUN S 00 DEGREES 33'35" W, A DISTANCE OF 30.00 FEET TO THE POINT OF BEGINNING.

TOGETHER WITH A 30 FOOT EASEMENT FOR INGRESS AND EGRESS BEING A PART OF THE SW ¼ OF THE SE ¼ OF SECTION 2, AND ALSO A PART OF THE NW ¼ OF THE NE ¼ OF SECTION 11, ALL BEING IN TOWNSHIP 3 SOUTH, RANGE 20 EAST, BAKER COUNTY, FLORIDA, MORE PARTICULARLY DESCRIBED AS FOLLOWS: BEGIN AT THE SW CORNER OF THE NW ¼ OF THE NE ¼ OF SECTION 11, TOWNSHIP 3 SOUTH, RANGE 20 EAST, AND RUN N 00 DEGREES 02'25" E, ALONG THE WEST LINE OF SAID NW ¼ OF THE NE ¼, ALSO BEING THE EAST LINE OF CITRUS ACRES, AS RECORDED IN PLAT BOOK 1, PAGE 9 OF THE PUBLIC RECORDS OF BAKER COUNTY, FLORIDA, A DISTANCE OF 1346.17 FEET TO A CONCRETE MONUMENT LS 1380 MARKING THE SW CORNER OF THE SW ¼ OF THE SE ¼ OF SECTION 2 AND ALSO BEING A POINT ON THE NORTH LINE OF SAID NW ¼ OF THE NE ¼ OF SECTION 11; THENCE N 86 DEGREES 39'14" E, ALONG SAID NORTH LINE OF SECTION 11, A DISTANCE OF 88.04 FEET TO THE SW CORNER OF PARCEL 136, DESCRIBED IN OFFICIAL RECORDS BOOK (ORB) 2002, PAGE 1970 BAKER COUNTY, FLORIDA; THENCE N 00 DEGREES 33'35" E ALONG THE WEST LINE OF SAID PARCEL 136, A DISTANCE OF 167.83 FEET TO A 5/8 INCH IRON ROD, LS 4708; THENCE N 86 DEGREES 38'34" E, A DISTANCE OF 30.07 FEET; THENCE S 00 DEGREES 33'35" W, PARALLEL TO THE WEST LINE OF SAID PARCEL 136, A DISTANCE OF 197.90 FEET; THENCE S 86 DEGREES 39'14" W, PARALLEL TO SAID NORTH LINE OF SECTION 11, A DISTANCE OF 87.78 FEET; THENCE S 00 DEGREES 02'25" W, PARALLEL TO SAID WEST LINE OF SAID NW ¼ OF THE NE ¼ OF SECTION 11, A DISTANCE OF 1316.08 FEET TO THE SOUTH LINE OF SAID NW ¼ OF THE NE ¼; THENCE S 86 DEGREES 34'35" W, ALONG SAID SOUTH LINE OF THE NW ¼ OF THE NE ¼, A DISTANCE OF 30.05 FEET TO THE POINT OF BEGINNING.

TOGETHER WITH AN EASEMENT FOR INGRESS AND EGRESS BEING MORE PARTICULARLY DESCRIBED AS FOLLOWS: THE SOUTH 60 FEET OF THE NORTH ½ OF THE NW ¼ OF SECTION 11 (ALSO BEING THE SOUTH 60 FEET OF CITRUS ACRES AS RECORDED IN PLAT BOOK 1 PAGE 9 OF THE PUBLIC RECORDS OF BAKER COUNTY, FLORIDA); THE WEST 30 FEET OF THE NORTH ½ OF THE NW ¼ OF SECTION 11; THE EAST 30 FEET OF THE NORTH ½ OF THE NE ¼ OF SECTION 10; THE WEST 30 FEET OF THE SW ¼ OF SECTION 2, LYING SOUTH OF GUNTER ROAD (A COUNTY MAINTAINED GRADED ROAD); THE EAST 30 FEET OF THE SE ¼ OF SECTION 3, LYING SOUTH OF GUNTER ROAD (A COUNTY MAINTAINED GRADED ROAD). THENCE SOUTHEASTERLY 30 FEET EITHER SIDE OF THE CENTER OF SAID GUNTER ROAD, 2600 FEET, MORE OR LESS, TO THE INTERSECTION WITH THE WESTERLY RIGHT OF WAY OF GASKINS CIRCLE (A 60 FOOT RIGHT OF WAY AS NOW ESTABLISHED) IN TOWNSHIP 2 SOUTH, RANGE 20 EAST, BAKER COUNTY, FLORIDA.



**Baker County**  
**Community Development Department**  
**Planning ~ Permitting ~ Code Enforcement ~ Building ~ Outreach**

360 East Shuey Avenue  
Macclenny, Florida 32063  
Phone (904) 259-2403  
Fax (904) 259-5057

**STAFF REPORT**

**DATE:** March 5, 2026

**TO:** Baker County Land Planning Agency & Baker County Board of Commissioners

**FROM:** LaDonna Combs, Director  
Community Development Department

**RE:** **Ordinance No. 2026-03 REZONING**  
**Agriculture 7.5 (AG 7.5) to Agriculture 5 (AG 5)**

---

**BACKGROUND**

Stephen Parker has submitted an application with the Baker County Community Development Department requesting a **REZONING FROM AGRICULTURE 7.5 (AG 7.5) to AGRICULTURE 5 (AG 5)**. The subject property is 10 acres, comprised of two (2) parcels (No. 31-3S-21-0000-0000-0100 & 31-3S-21-0000-0000-0030), and is located at 12031 Clet Harvey Rd. The property is currently in compliance with current zoning standards. However, the applicant's intention is to split the property evenly between two (2) siblings, thus creating two (2) parcels, each containing 5 acres.

**INTENT**

The subject parcel has a land use designation of Agriculture B (AG B) and a zoning district of Agriculture 7.5 (AG 7.5). The Applicants propose a change in zoning (Ordinance 2026-03) from **AGRICULTURE 7.5 (AG 7.5) to AGRICULTURE 5 (AG 5)**.

The subject parcel is bound by the following land use designations and zoning districts:

North: Agriculture B / Agriculture 7.5

South: Agriculture B / Agriculture 7.5

East: Agriculture B / Agriculture 7.5

West: Agriculture B / Agriculture 7.5

## ORDINANCE CODE

The applicant requests to amend the Zoning Map by changing the current zoning. The following are relevant land development regulations from the Baker County Ordinance Code:

### CURRENT ZONING DISTRICT

#### **Sec. 24-191. - AG 7.5 Agricultural District.**

(a) *Generally.* This section applies to the AG 7.5 Agricultural District. The purpose of classifying land and water areas within this district is to preserve the rural and open character of lands within the Agricultural B land use category of the comprehensive plan and to provide for permanent residential housing in conjunction with agricultural uses. Furthermore, this district is to be used to protect agricultural lands from premature development. One unit per 7.5 acres to one unit per 19 acres will be permitted. Development must meet building codes and have a county department of health approved well and septic tank installation. Accessory uses and special uses are also permitted.

(b) *Permitted uses and structures.*

(1) Within any AG 7.5 district, permitted uses and structures allowed by right are as follows:

- a. Church.
- b. Farming.
- c. Feed store (site plan review).
- d. Fishponds (two acres or less).
- e. Golf course/club.
- f. Guest house site plan review).
- g. Labor camp (site plan review).
- h. Mobile home (one unit per 7.5 acres).
- i. Private riding stable (site plan review; see section 24-148(c)).
- j. Public riding stable (site plan review; see section 24-148(d)).
- k. Roadside produce stand.
- l. Silviculture.
- m. Single-family (one unit per 7.5 acres).
- n. Special use (see section 24-234).
- o. Sports club.
- p. Temporary use (see section 24-234).
- q. Veterinary clinic (site plan review).
- r. Borrow pits with a surface area totaling less than ten acres in size which meet the requirements of section 24-161.

(2) Additionally, within any AG 7.5 district the following accessory uses, and structures are allowed:

- a. Storage buildings, sheds, tool houses and private garages.
- b. Noncommercial greenhouses and plant nurseries.
- c. Play equipment.
- d. Household pets.
- e. Swimming pools.

(c) *Permissible uses by special exception.*

- (1) Feed lot (site plan review).
- (2) Family lot division.

- (3) Kennel.
  - (4) Sawmill.
  - (5) Slaughterhouse (site plan review).
  - (6) Homestead division (site plan review).
  - (7) Wireless telecommunication facilities (see section 24-235).
  - (8) Semi-public uses.
    - a. Club.
    - b. Lodge.
    - c. Recreational association.
    - d. Neighborhood association.
  - (9) Borrow pits with a surface area totaling less than ten acres in size which meet the requirements of section 24-161.
- (d) *Permissible use by mine permit.*
- (1) Excavation, mining, and mineral extraction (see section 24-159; on ten acres or more).
- (e) *Permissible uses by limited notice.*
- (1) Day care center.
  - (2) Home occupation.
- (f) *Setback and other standards.*
- (1) Minimum lot requirements (width and area).
    - a. Width: 200 feet.
    - b. Area: 7.5 acres.
  - (2) Maximum lot coverage by all buildings and structures.
    - a. Not applicable.
  - (3) Minimum yard requirements.
    - a. Front: 50 feet.
    - b. Side: 30 feet.
    - c. Rear: 25 feet.
  - (4) Maximum height of structures. Maximum height of structures shall be 35 feet.

## PROPOSED ZONING DISTRICT

### **Section 24.191.01 – AG 5 Agricultural District.**

- (a) *Generally.* This section applies to the AG 5.0 Agricultural District. The purpose of classifying land and water areas within this district is to preserve the rural and open character of lands within the Agricultural B land use category of the Comprehensive Plan and to provide for permanent residential housing in conjunction with agricultural uses. Furthermore, this district is to be used to protect agricultural lands from premature development. One unit per 5.0 acres to 7.4 acres will be permitted. Development must meet building codes and have a county department of health approved well and septic tank installation. Accessory uses and special uses are also permitted.
- (b) *Permitted uses and structures.*
- (1) Within any AG 5.0 district, permitted uses and structures allowed by right are as follows:
    - a. Church.
    - b. Farming.
    - c. Feed store (site plan review).

- d. Fishponds (two acres or less).
- e. Golf course/club.
- f. Guest house (site plan review).
- g. Labor camp (site plan review).
- h. Mobile home (one unit per 5.0 acres).
- i. Private riding stable (site plan review; see Section 24-148(c)).
- j. Public riding stable (site plan review; see Section 24-148(d)).
- k. Roadside produce stand.
- l. Silviculture.
- m. Single-family (one unit per 5.0 acres).
- n. Special use (see Section 24-234).
- o. Sports club.
- p. Temporary use (see Section 23-234).
- q. Veterinary clinic (site plan review).

- (2) Additionally, within any AG 5.0 district, the following accessory uses, and structures are allowed by right:
- a. Storage buildings, sheds, tool houses, and private garages.
  - b. Noncommercial greenhouses and plant nurseries.
  - c. Play equipment.
  - d. Household pets.
  - e. Swimming pools.

(c) *Permissible uses by special exception.*

- (1) Family lot division.
- (2) Kennel.
- (3) Sawmill.
- (4) Homestead division (site plan review).
- (5) Wireless telecommunication facilities (see Section 24-235).
- (6) Semi-public uses.
  - a. Club.
  - b. Lodge.
  - c. Recreational association.
  - d. Neighborhood association.

(d) *Permissible uses by limited notice.*

- (1) Day care center.
- (2) Home occupation.

(e) *Setback and other standards.*

- (1) Minimum lot requirements (width and area).
  - a. Width: 200 feet.
  - b. Area: 5.0 acres.
- (2) Maximum lot coverage by all buildings and structures.
  - a. Not applicable.
- (3) Minimum yard requirements.
  - a. Front: Fifty (50) feet.
  - b. Side: Thirty (30) feet.
  - c. Rear: Twenty-Five (25) feet.
- (4) Maximum height of structures shall be thirty-five (35) feet.



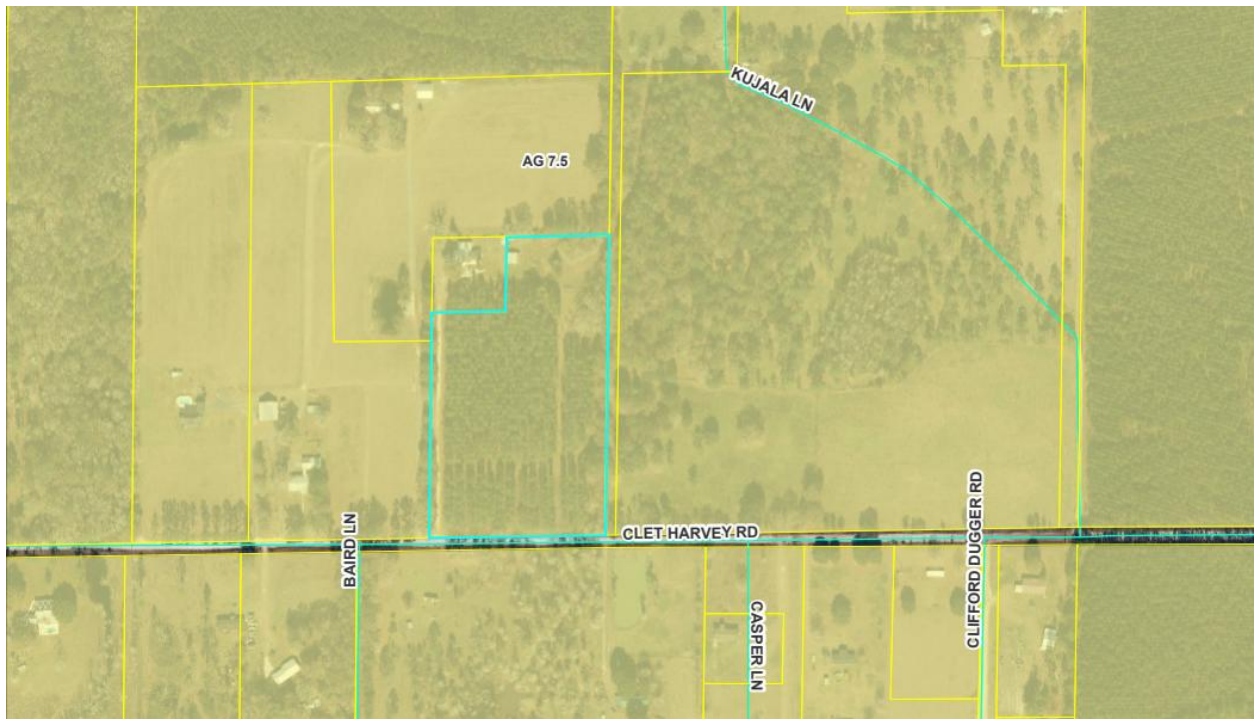
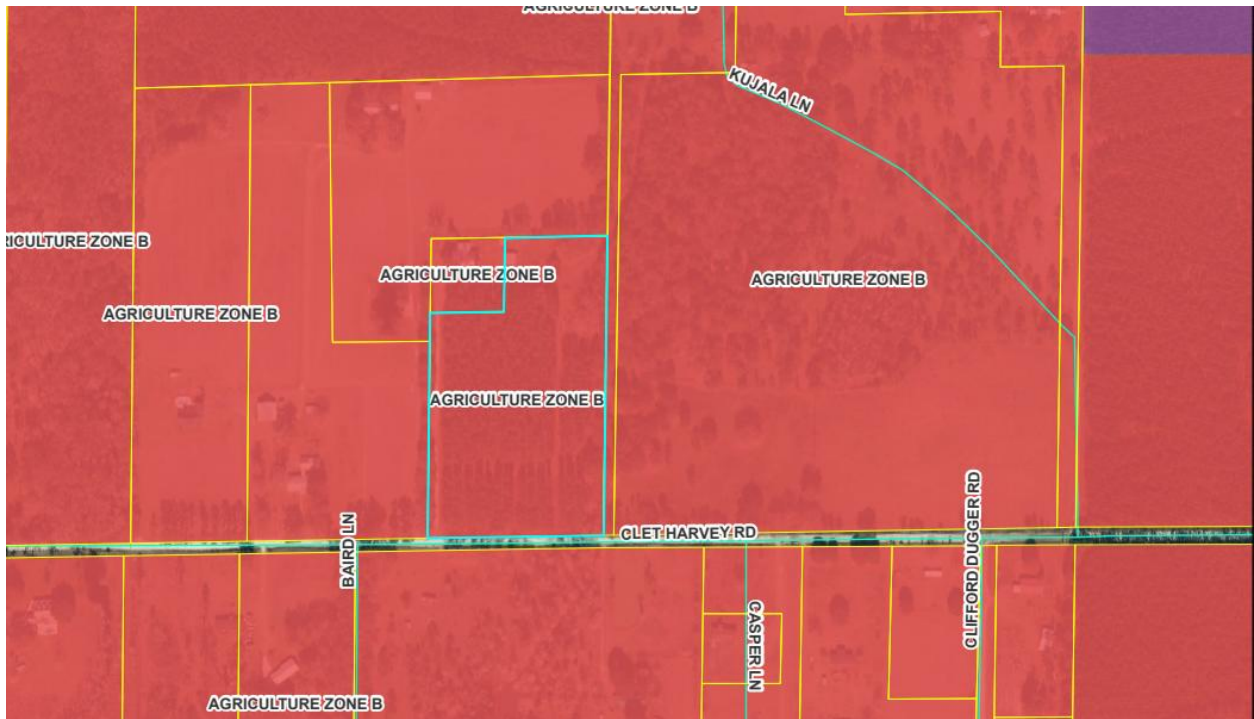

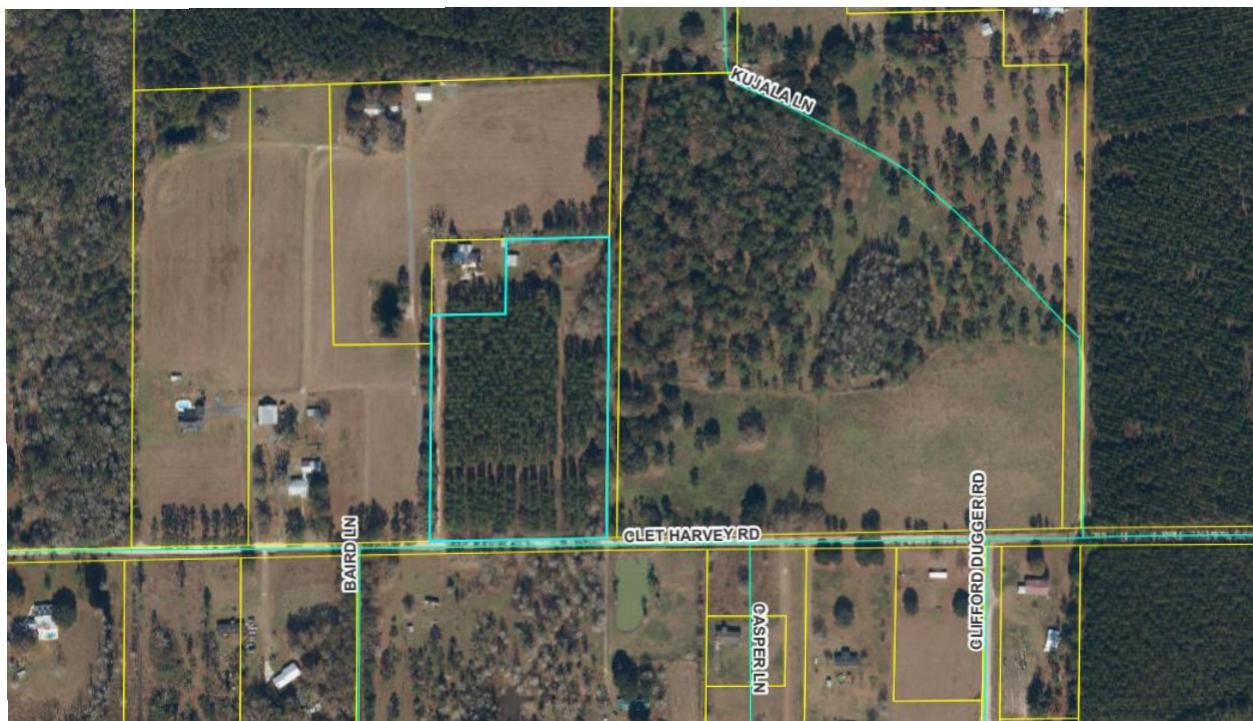
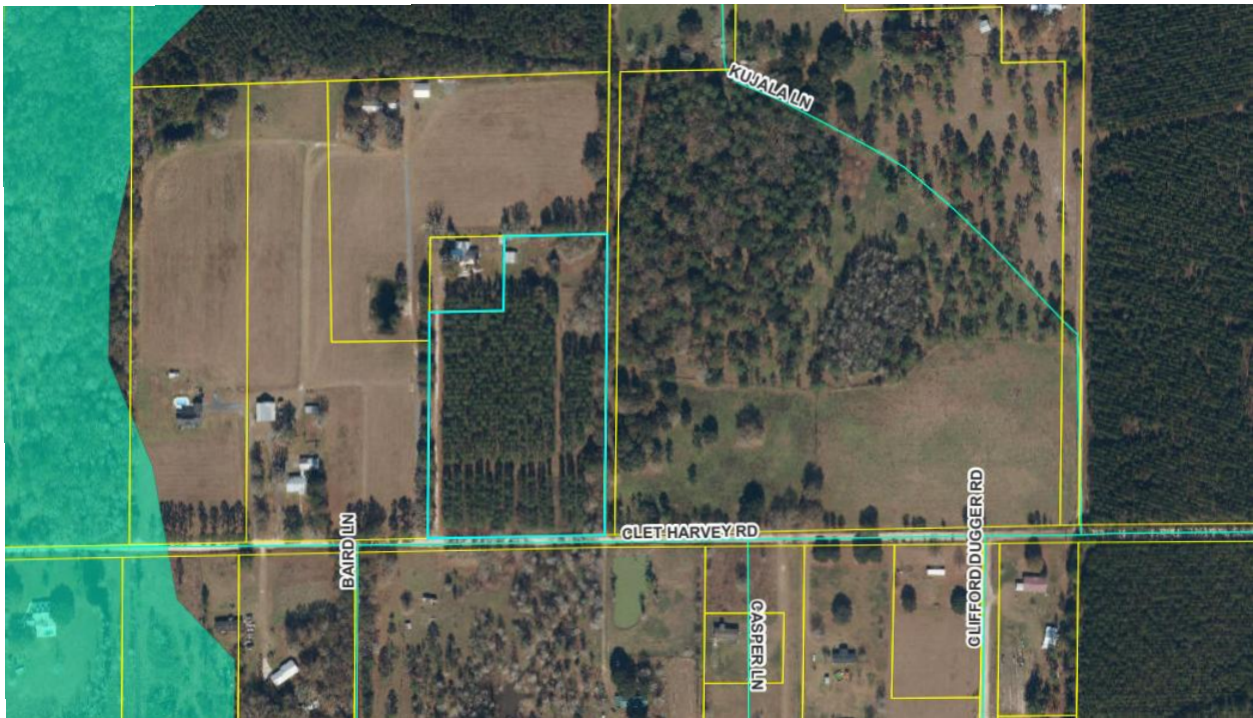

**ORDINANCE 2026-03**

**AN ORDINANCE OF THE BOARD OF COUNTY COMMISSIONERS OF BAKER COUNTY, FLORIDA AMENDING THE BAKER COUNTY ZONING MAP BY RECLASSIFYING APPROXIMATELY 10.00 +/- ACRES OF REAL PROPERTY OWNED BY STEPHEN PARKER FROM AGRICULTURE 7.5 (AG 7.5) TO AGRICULTURE 5 (AG 5) WITH THE INTENT OF BRINGING THE PARCEL INTO COMPLIANCE WITH ITS ACREAGE; PROVIDING FOR A CHANGE OF ZONING; PROVIDING DIRECTIONS FOR RECORDING; PROVIDING FOR SEVERABILITY; AND PROVIDING AN EFFECTIVE DATE.**

**WHEREAS**, the Community Planning Act; Section 163.3161 through 163.3215, Florida Statutes, require that each local government prepare and adopt a comprehensive land use plan, Zoning Map, and regulations; and

**WHEREAS**, the Board of County Commissioners of Baker County, Florida wishes to amend the Baker County Zoning Map; and

**WHEREAS**, the proposed zoning change is for approximately **10.00 +/- acres** of real property owned by **STEPHEN PARKER**; and

**WHEREAS**, the corresponding parcel identification number is **31-3S-21-0000-0000-0100 & 31-3S-21-0000-0000-0030**; and

**WHEREAS**, a duly advertised public hearing was conducted on **Tuesday, March 10, 2026 after 6:00 P.M.** by the Baker County Land Planning Agency (LPA); and the LPA provided its recommendations to the Board of County Commissioners of Baker County, Florida; and

**WHEREAS**, the Board of County Commissioners of Baker County, Florida held a duly advertised public hearing on **Tuesday, March 17, 2026 after 6:00 P.M.** for the purpose of hearing public comments; and

**WHEREAS**, the Board of County Commissioners of Baker County, Florida considered the recommendations of the LPA at the duly advertised public hearing held on **Tuesday, April 7, 2026 after 6:00 P.M.** and approved the Rezoning; and

**WHEREAS**, the Board of County Commissioners of Baker County, Florida finds that the adoption of this ordinance for the Rezoning, the amendment to the Baker County Zoning Map, and the reclassification of real property described herein is consistent with the Goals, Objectives, and

Policies of the Baker County Comprehensive Plan and the Land Development Regulations of the Baker County Ordinance Code and is in the best interest of Baker County, Florida and its citizens.

**NOW THEREFORE, BE IT ORDAINED** by the Board of County Commissioners of Baker County, Florida as follows:

Section 1. Adoption and Incorporation of Recitals. The Board of County Commissioners of Baker County, Florida hereby adopts the above recitals and incorporates them herein as a part of this ordinance.

Section 2. Ownership and Description of Property. The real property reclassified by this Ordinance is owned by **STEPHEN PARKER** and identified by the Baker County Property Appraiser Identification Number: **31-3S-21-0000-0000-0100 & 31-3S-21-0000-0000-0030**; and is more particularly described in “Exhibit 1” which is attached hereto and incorporated herein by reference.

Section 3. Purpose and Authority of Ordinance. This Ordinance is adopted for the purpose of rezoning the above described real property pursuant to chapter 24 of the Baker County Land Development Regulations.

Section 4. Direction to Staff. Following approval by the Board of County Commissioners of Baker County, Florida, the staff of the Community Development Department is directed to file the same in the Official Records of Baker County, Florida.

Section 5. Recording of Ordinance. Following approval by the Board of County Commissioners of Baker County, Florida, the staff of the Clerk of the Court is directed to file the same in the Official Records of Baker County, Florida.

Section 6. Effective Date of Ordinance. This Ordinance shall become effective upon adoption by the Board of County Commissioners of Baker County, Florida.

**PASSED AND ADOPTED** with a quorum present and voting, by the Board of County Commission of Baker County, Florida, in regular session, this **Tuesday, April 7, 2026**.

**BOARD OF COUNTY COMMISSIONERS OF  
BAKER COUNTY, FLORIDA**

---

**RONALD MANN, CHAIR  
COUNTY COMMISSION**

**ATTEST:**

---

**STACIE HARVEY  
CLERK OF THE BOARD**

## EXHIBIT 1

Begin at the Southeast corner of the SW 1/4 of the SE 1/4, Section 31, Township 3 South, Range 21 East and run S 88 degrees 50' W, along the South line of said Section 31, 500.00 feet, thence N 0 degrees 15' E, 661 feet to the Point of Beginning, thence continue N 0 degrees 15' E, 210 feet, thence N 88 degrees 50' E, 210 feet, thence S 0 degrees 15' W, 210 feet, thence S88 degrees 50' W, 210 feet to the Point of Beginning.

## EXHIBIT 2

### PARCEL 1

A PARCEL OF LAND BEING A PORTION OF LAND RECORDED IN INSTRUMENT # 200300001536 OF THE PUBLIC RECORDS OF BAKER COUNTY, FLORIDA, SAID PARCEL LYING IN THE SOUTHWEST 1/4 OF THE SOUTHEAST 1/4 OF SECTION 31, TOWNSHIP 3 SOUTH, RANGE 21 EAST AND BEING MORE PARTICULARLY DESCRIBED AS FOLLOWS:

BEGIN AT THE SOUTHEAST CORNER OF LAND DESCRIBED IN INSTRUMENT # 200300001536 OF THE PUBLIC RECORDS OF BAKER COUNTY, FLORIDA, SAID BEGINNING ALSO BEING THE SOUTHEAST CORNER OF THE SOUTHWEST 1/4 OF THE SOUTHEAST 1/4 OF SECTION 31, TOWNSHIP 3 SOUTH, RANGE 21 EAST; THENCE SOUTH 88°06'29" WEST, ON THE SOUTH LINE OF SAID SECTION 31, A DISTANCE OF 250.06 FEET; THENCE DEPARTING SAID SOUTH LINE, NORTH 0°10'10" WEST, A DISTANCE OF 871.00 FEET TO THE NORTH LINE OF AFOREMENTIONED LAND DESCRIBED IN INSTRUMENT # 200300001536; THENCE NORTH 88°06'29" EAST, ON SAID NORTH LINE, A DISTANCE OF 250.06 FEET TO THE NORTHEAST CORNER OF SAID LAND AND THE EAST LINE OF THE SOUTHWEST 1/4 OF THE SOUTHEAST 1/4; THENCE SOUTH 0°10'10" EAST, ON THE EAST LINE OF SAID LAND AND SOUTHWEST 1/4 OF THE SOUTHEAST 1/4, A DISTANCE OF 871.00 FEET TO THE POINT OF BEGINNING.

SUBJECT TO ANY PORTION LYING WITHIN THE MAINTAINED RIGHT OF WAY OF CLET HARVEY ROAD (A COUNTY MAINTAINED GRADED RIGHT OF WAY)

### PARCEL 2

A PARCEL OF LAND BEING A PORTION OF LAND RECORDED IN INSTRUMENT # 200300001536 OF THE PUBLIC RECORDS OF BAKER COUNTY, FLORIDA, SAID PARCEL LYING IN THE SOUTHWEST 1/4 OF THE SOUTHEAST 1/4 OF SECTION 31, TOWNSHIP 3 SOUTH, RANGE 21 EAST AND BEING MORE PARTICULARLY DESCRIBED AS FOLLOWS:

COMMENCE AT THE SOUTHEAST CORNER OF LAND DESCRIBED IN INSTRUMENT # 200300001536 OF THE PUBLIC RECORDS OF BAKER COUNTY, FLORIDA, SAID COMMENCEMENT ALSO BEING THE SOUTHEAST CORNER OF THE SOUTHWEST 1/4 OF THE SOUTHEAST 1/4 OF SECTION 31, TOWNSHIP 3 SOUTH, RANGE 21 EAST; THENCE SOUTH 88°06'29" WEST, ON THE SOUTH LINE OF SAID SECTION 31, A DISTANCE OF 250.06 FEET TO THE POINT OF BEGINNING; THENCE CONTINUE SOUTH 88°06'29" WEST, ON SAID SOUTH LINE, A DISTANCE OF 249.94 FEET TO THE SOUTHWEST CORNER OF AFOREMENTIONED LAND DESCRIBED IN INSTRUMENT # 200300001536; THENCE DEPARTING SAID SOUTH LINE, NORTH 0°10'10" WEST, ON THE WEST LINE OF SAID LAND, A DISTANCE OF 661.00 FEET TO THE SOUTHWEST CORNER OF LAND DESCRIBED IN INSTRUMENT # 202000001990; THENCE NORTH 88°06'29" EAST, ON THE SOUTH LINE OF SAID LAND, 210.00 FEET TO THE SOUTHEAST CORNER OF SAID LAND; THENCE NORTH 0°10'10" WEST, ON THE EAST LINE OF SAID LAND, 210.00 FEET TO THE NORTHEAST CORNER OF SAID LAND; THENCE NORTH 88°06'29" EAST, ON THE NORTH LINE OF AFORESAID LAND DESCRIBED IN INSTRUMENT # 200300001536, A DISTANCE OF 39.94 FEET; THENCE DEPARTING SAID NORTH LINE, SOUTH 0°10'10" EAST, A DISTANCE OF 871.00 FEET TO THE POINT OF BEGINNING.

SUBJECT TO ANY PORTION LYING WITHIN THE MAINTAINED RIGHT OF WAY OF CLET HARVEY ROAD (A COUNTY MAINTAINED GRADED RIGHT OF WAY)



**Baker County  
Community Development Department  
Planning ~ Permitting ~ Code Enforcement ~ Building ~ Outreach**

360 East Shuey Avenue  
Macclenny, Florida 32063  
Phone (904) 259-2403

**STAFF REPORT**

**DATE:** March 5, 2026  
**TO:** Baker County Land Planning Agency & Baker County Board of Commissioners  
**FROM:** LaDonna Combs, Director  
Community Development Department  
**RE:** **Ordinance No. 2026-04 SMALL SCALE LAND USE AMENDMENT  
Agriculture B (AG B) to Very Low Density Residential (VLDR)**

---

**BACKGROUND**

Raymond & Karen Bailey have submitted two (2) applications to the Baker County Community Development Department requesting a change in land use and zoning. The 5.01-acre parcel (No. 08-2S-22-0000-0000-0215) is located at 5611 CR 23C, Macclenny, FL 32063. This parcel was created prior to current zoning standards. The applicant intends to bring the parcel into compliance with current standards, as well as prepare for the creation of a 2.5-acre family lot for their child. The companion rezoning ordinance requests a change from AG 7.5 to RCMH 2.5.

**INTENT**

The subject parcel has a land use designation of Agriculture B (AG B) and a zoning district of Agriculture 7.5 (AG 7.5). The Applicant proposes a land use amendment (Ordinance 2026-04) from **AGRICULTURE B (AG B) TO VERY LOW DENSITY RESIDENTIAL (VLDR)** and a companion rezoning (Ordinance 2026-05) from **AGRICULTURE 7.5 (AG 7.5) TO RESIDENTIAL CONVENTIONAL MOBILE HOME 2.5 (RCMH 2.5)**.

The subject parcel is bound by the following land use designations and zoning districts:

- North: Agriculture B / Agriculture 7.5
- South: Agriculture B / Agriculture 7.5
- East: Agriculture B / Agriculture 7.5
- West: Very Low Density Residential / Residential Conventional 1

## CURRENT LAND USE CATEGORY

### **Policy A.1.10.1 Agriculture**

#### **B. Agriculture Ag B**

The category Ag B is in transition because of development potential because of location. Ag B lands lie at the fringe of developing areas, along major transportation routes or are contained within an area characterized by numerous pockets of already developed parcels. Mining and Mineral Extraction (mining) activities are allowed provided that before commencement of construction such activities have a conceptual reclamation permit approved by Baker County and the Department of Environmental Protection (including activities in floodplains and wetland areas) and any required state and federal permits for wetland impacts and shall be managed in accordance with the provisions of the Conservation Element and the Land Development Regulations. Borrow pits and fishponds are allowed.

Ag B lands are intended to be used for small-scale agriculture activities such as cultivation of field crops, livestock, dairies, or other uses on a limited scale.

Ag B lands may be developed at a maximum density of one (1) dwelling unit per 5 acres.

## PROPOSED LAND USE CATEGORY

### **Policy A.1.10.2 Residential**

The residential land use category includes single family detached, single family attached, duplex, and multi-family housing. Parcels of land designated for residential land uses are intended to be used predominately for housing and should be protected from intrusion of land uses that are incompatible with residential density or intensity of use.

The following minimum criteria pertain to residential land use categories:

- All development must meet building codes and have either a County Department of Health approved well and septic tank installation or connection to central water/sewer facilities.
- Compliance with the Concurrency Management System is required before development will be permitted at the stated densities/intensities of use.
- **Very Low Density**  
Range of density from a maximum density of 1 dwelling unit per acre to a minimum of 1 unit per 7.5 acres, which will include zoning categories: Ag 7.5, RCMH1, RC1, and RCMH 2.5.

### **DEVELOPMENT REVIEW COMMITTEE COMMENTS**

The application was circulated to the DRC Members, and the following reflect their comments:

#### **Baker County Fire and Rescue / Trevor Nelson, Chief**

- No issues.

#### **Environmental Health / Ryan McFadden**

- No issues.

#### **Public Works Department / Chris Lee, Director**

- No issues.

#### **School District / Chadd Scarborough**

- No comments.

#### **County Manager / Sara Little**

- No issues.

**RECOMMENDATION**  
 Staff recommends **APPROVAL** of the proposed Small Scale Land Use Amendment for **Ordinance 2026-04** requesting change of **AGRICULTURE B (AG B)** to **VERY LOW DENSITY RESIDENTIAL (VLDR)**.

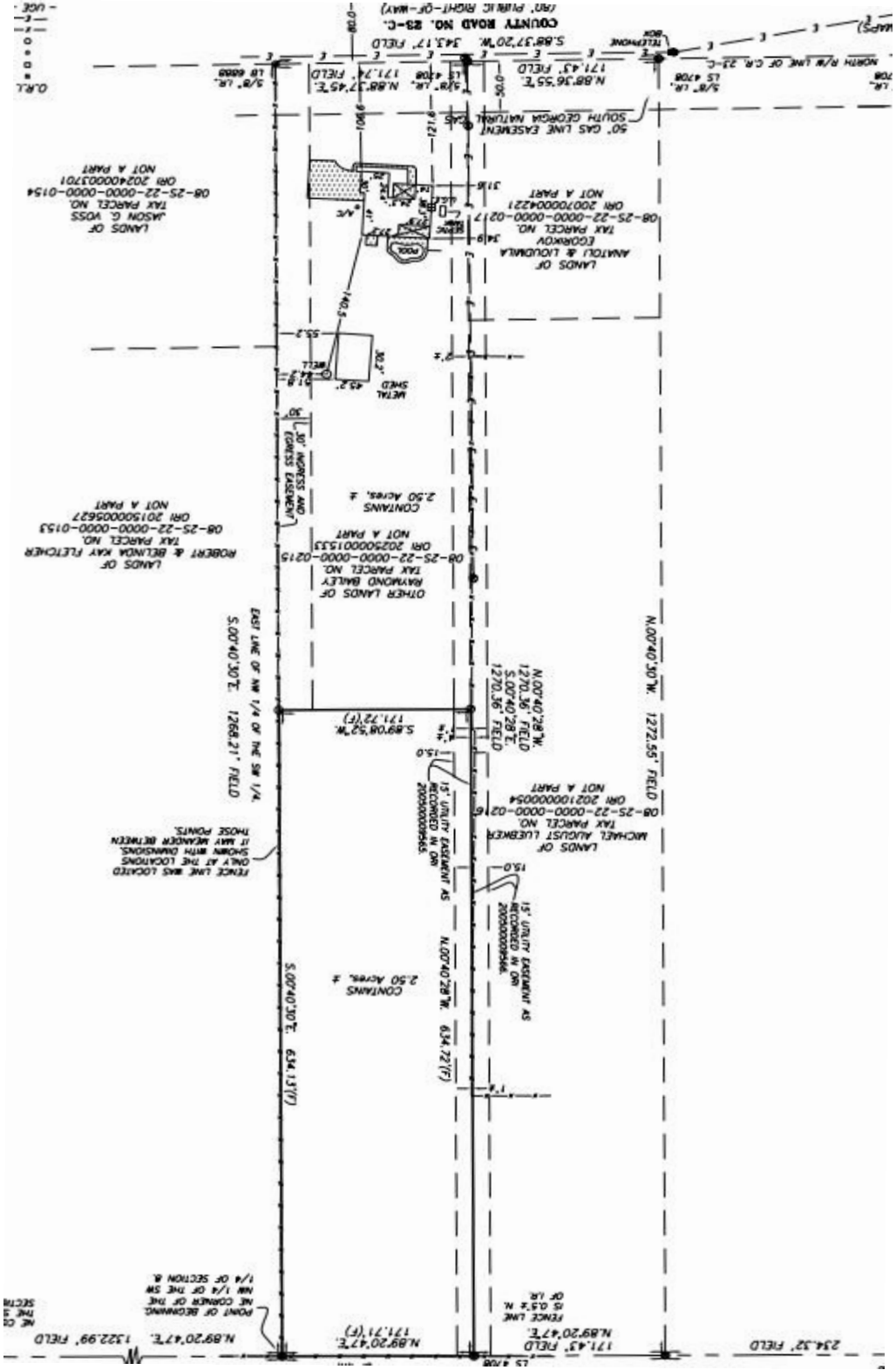

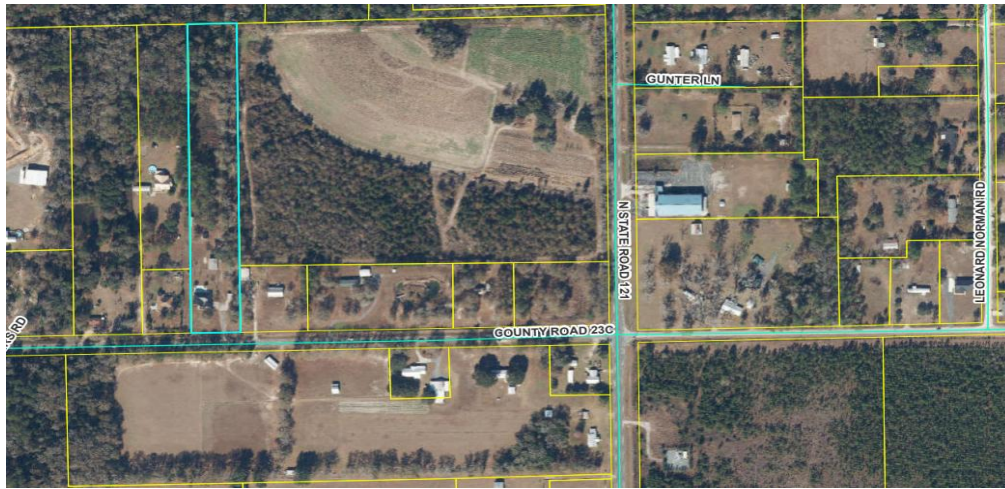

**ORDINANCE 2026-04**

**AN ORDINANCE OF THE BOARD OF COUNTY COMMISSIONERS OF BAKER COUNTY, FLORIDA MAKING A SMALL SCALE AMENDMENT TO THE BAKER COUNTY COMPREHENSIVE PLAN BY RECLASSIFYING APPROXIMATELY 5.01 +/- ACRES OF REAL PROPERTY OWNED BY RAYMOND & KAREN BAILEY FROM AGRICULTURE B (AG B) TO VERY LOW DENSITY RESIDENTIAL (VLDR) IN ORDER TO BRING THE PARCEL INTO COMPLIANCE ON THE FUTURE LAND USE MAP; PROVIDING FINDINGS BY THE BOARD OF COUNTY COMMISSIONERS; PROVIDING DIRECTION FOR RECORDING; PROVIDING FOR SEVERABILITY; AND PROVIDING AN EFFECTIVE DATE.**

**WHEREAS**, the Community Planning Act; Section 163.3161 through 163.3215, Florida Statutes, require that each local government prepare and adopt a comprehensive land use plan, Zoning Map, and regulations; and

**WHEREAS**, Section 163.3184, Florida Statutes, requires that any amendment to the Baker County Comprehensive Plan or any element of portion thereof be made by ordinance; and

**WHEREAS**, the Board of County Commissioners of Baker County, Florida wishes to amend the Baker County Future Land Use Map; and

**WHEREAS**, the proposed small scale amendment to the Baker County Future Land Use Map is for approximately **5.00 +/-** acres of real property owned by **RAYMOND & KAREN BAILEY**; and

**WHEREAS**, the corresponding parcel identification number is **08-2S-22-0000-0000-0215**; and

**WHEREAS**, a duly advertised public hearing was conducted on **Tuesday, March 10, 2026 after 6:00 P.M.** by the Baker County Land Planning Agency (LPA); and the LPA provided its recommendations to the Board of County Commissioners of Baker County, Florida; and

**WHEREAS**, the Board of County Commissioners of Baker County, Florida held a duly advertised public hearing on **Tuesday, March 17, 2026 after 6:00 P.M.** for the purpose of hearing public comments; and

**WHEREAS**, the Board of County Commissioners of Baker County, Florida considered the recommendations of the LPA at the duly advertised public hearing held on **Tuesday, April 7,**

**2026 after 6:00 P.M.** and approved the amendment to the Baker County Future Land Use Map; and

**WHEREAS**, the Board of County Commissioners of Baker County, Florida finds that the adoption of this ordinance for the amendment to the Baker County Future Land Use Map, and the reclassification of real property described herein is consistent with the Goals, Objectives, and Policies of the Baker County Comprehensive Plan is in the best interest of Baker County, Florida and its citizens.

**NOW THEREFORE, BE IT ORDAINED** by the Board of County Commissioners of Baker County, Florida as follows:

Section 1. Adoption and Incorporation of Recitals. The Board of County Commissioners of Baker County, Florida hereby adopts the above recitals and incorporates them herein as a part of this ordinance.

Section 2. Ownership and Description of Property. The real property reclassified by this Ordinance is owned by **RAYMOND & KAREN BAILEY** and identified by the Baker County Property Appraiser Identification Number: **08-2S-22-0000-0000-0215**; and is more particularly described in “Exhibit 1” which is attached hereto and incorporated herein by reference.

Section 3. Purpose and Authority of Ordinance. This Ordinance is adopted for the purpose of allowing for an amendment to the Baker County Future Land Use Map.

Section 4. Reclassification of Property. The Board of County Commissioners of Baker County, Florida reclassifies the parcel of real property described in “Exhibit 1” from **AGRICULTURAL B (AG B) TO VERY LOW DENSITY RESIDENTIAL (VLDR)** on the Future Land Use Map of the Baker County Comprehensive Plan.

Section 5. Direction to Staff. Following approval by the Board of County Commissioners of Baker County, Florida, the staff of the Community Development Department is directed to file the same in the Official Records of Baker County, Florida.

Section 6. Recording of Ordinance. Following approval by the Board of County Commissioners of Baker County, Florida, the staff of the Clerk of the Court is directed to file the same in the Official Records of Baker County, Florida.

Section 7. Effective Date of Ordinance. This Ordinance shall become effective upon adoption by the Board of County Commissioners of Baker County, Florida.

**PASSED AND ADOPTED** with a quorum present and voting, by the Board of County Commission of Baker County, Florida, in regular session, this **Tuesday, April 7, 2026**.

**BOARD OF COUNTY COMMISSIONERS OF  
BAKER COUNTY, FLORIDA**

---

**RONALD MANN, CHAIR  
COUNTY COMMISSION**

**ATTEST:**

---

**STACIE HARVEY  
CLERK OF THE BOARD**

## EXHIBIT 1

Part of the NW 1/4 of the SW 1/4 of Section 8, Township 2 South, Range 22 East, Baker County, Florida, more particularly described as follows:

Commence at the NW corner of the NW 1/4 of the SW 1/4 of said Section 8 and thence North  $89^{\circ}20'47''$  East, along the North line of said NW 1/4 of the SW 1/4 a distance of 979.85 feet; thence continue North  $89^{\circ}20'47''$  East, 171.43 feet to the Point of Beginning; thence continue North  $89^{\circ}20'47''$  East, 171.71 feet to the NE corner of said NW 1/4 of the SW 1/4; thence South  $00^{\circ}40'30''$  East, along the East line of said NW 1/4 of the SW 1/4, a distance of 1268.21 feet to the North right-of-way line of County Road No. 23-C, an 80 foot wide public right of way; thence South  $88^{\circ}37'20''$  West, along said North right-of-way line, 171.74 feet; thence North  $00^{\circ}40'28''$  West, 1270.36 feet to the Point of Beginning.

Subject to a 50 foot wide gas line easement over and across the South 50 feet of the above described lands.



**Baker County  
Community Development Department  
Planning ~ Permitting ~ Code Enforcement ~ Building ~ Outreach**

360 East Shuey Avenue  
Macclenny, Florida 32063  
Phone (904) 259-2403  
Fax (904) 259-5057

**STAFF REPORT**

**DATE:** March 5, 2026  
**TO:** Baker County Land Planning Agency & Baker County Board of Commissioners  
**FROM:** LaDonna Combs, Director  
Community Development Department  
**RE:** **Ordinance No. 2026-05 REZONING  
Agriculture 7.5(AG 7.5) to Residential Conventional Mobile Home 2.5 (RCMH2.5)**

---

**BACKGROUND**

Raymond & Karen Bailey have submitted two (2) applications to the Baker County Community Development Department requesting a change in land use and zoning. The 5.01-acre parcel (No. 08-2S-22-0000-0000-0215) is located at 5611 CR 23C, Macclenny, FL 32063. This parcel was created prior to current zoning standards. The applicant intends to bring the parcel into compliance with current standards, as well as prepare for the creation of a 2.5-acre family lot for their child. The companion land use application requests a change from Agriculture B to Very Low Density Residential.

**INTENT**

The subject parcel has a land use designation of Agriculture B (AG B) and a zoning district of Agriculture 7.5 (AG 7.5). The Applicant proposes a zoning change (Ordinance 2026-05) from **AGRICULTURE 7.5 (AG 7.5) TO RESIDENTIAL CONVENTIONAL MOBILE HOME 2.5 (RCMH 2.5)** and a companion land use amendment (Ordinance 2026-04) from **AGRICULTURE B (AG B) TO VERY LOW DENSITY RESIDENTIAL (VLDR)**.

The subject parcel is bound by the following land use designations and zoning districts:

North: Agriculture B / Agriculture 7.5

South: Agriculture B / Agriculture 7.5

East: Agriculture B / Agriculture 7.5

West: Very Low Density Residential / Residential Conventional 1

## ORDINANCE CODE

The applicant requests to amend the Zoning Map by changing the current zoning. The following are relevant land development regulations from the Baker County Ordinance Code:

### CURRENT ZONING DISTRICT

#### **Sec. 24-191. - AG 7.5 Agricultural District (AG 7.5).**

- (a) *Generally.* This section applies to the AG 7.5 Agricultural District. The purpose of classifying land and water areas within this district is to preserve the rural and open character of lands within the Agricultural B land use category of the comprehensive plan and to provide for permanent residential housing in conjunction with agricultural uses. Furthermore, this district is to be used to protect agricultural lands from premature development. One unit per 7.5 acres to one unit per 19 acres will be permitted. Development must meet building codes and have a county department of health approved well and septic tank installation. Accessory uses and special uses are also permitted.
- (b) *Permitted uses and structures.*
- (1) Within any AG 7.5 district, permitted uses and structures allowed by right are as follows:
    - a. Church.
    - b. Farming.
    - c. Feed store (site plan review).
    - d. Fishponds (two acres or less).
    - e. Golf course/club.
    - f. Guest house site plan review).
    - g. Labor camp (site plan review).
    - h. Mobile home (one unit per 7.5 acres).
    - i. Private riding stable (site plan review; see section 24-148(c)).
    - j. Public riding stable (site plan review; see section 24-148(d)).
    - k. Roadside produce stand.
    - l. Silviculture.
    - m. Single-family (one unit per 7.5 acres).
    - n. Special use (see section 24-234).
    - o. Sports club.
    - p. Temporary use (see section 24-234).
    - q. Veterinary clinic (site plan review).
    - r. Borrow pits with a surface area totaling less than ten acres in size which meet the requirements of section 24-161.
  - (2) Additionally, within any AG 7.5 district the following accessory uses, and structures are allowed:
    - a. Storage buildings, sheds, tool houses and private garages.
    - b. Noncommercial greenhouses and plant nurseries.
    - c. Play equipment.
    - d. Household pets.
    - e. Swimming pools.
- (c) *Permissible uses by special exception.*
- (1) Feed lot (site plan review).
  - (2) Family lot division.
  - (3) Kennel.
  - (4) Sawmill.
  - (5) Slaughterhouse (site plan review).
  - (6) Homestead division (site plan review).
  - (7) Wireless telecommunication facilities (see section 24-235).
  - (8) Semi-public uses.
    - a. Club.
    - b. Lodge.

- c. Recreational association.
- d. Neighborhood association.
- (9) Borrow pits with a surface area totaling less than ten acres in size which meet the requirements of section 24-161.
- (d) *Permissible use by mine permit.*
  - (1) Excavation, mining, and mineral extraction (see section 24-159; on ten acres or more).
- (e) *Permissible uses by limited notice.*
  - (1) Day care center.
  - (2) Home occupation.
- (f) *Setback and other standards.*
  - (1) Minimum lot requirements (width and area).
    - a. Width: 200 feet.
    - b. Area: 7.5 acres.
  - (2) Maximum lot coverage by all buildings and structures.
    - a. Not applicable.
  - (3) Minimum yard requirements.
    - a. Front: 50 feet.
    - b. Side: 30 feet.
    - c. Rear: 25 feet.
  - (4) Maximum height of structures. Maximum height of structures shall be 35 feet.

## PROPOSED ZONING DISTRICT

### Section 24-192. Residential Conventional and Mobile Home 2.5 District.

- (a) *Generally.* The provisions of this section apply to the RCMH 2.5 Residential Conventional and Mobile Home District. The purpose of classifying land and water areas within this district is to provide a transition between agriculture and residential uses and to accommodate large lot residential development of single-family conventional and mobile homes within the Very Low Density land use category of the comprehensive plan. One unit per 2½ acres will be permitted. Development must meet building codes and have a county department of health approved well and septic tank installation. Accessory uses and special uses are also permitted.
- (b) *Permitted uses and structures.*
  - (1) Within any RCMH 2.5 district, permitted uses and structures allowed by right are as follows:
    - a. Church.
    - b. Community residential facility, Type A.
    - c. Country club.
    - d. Fishponds (two acres or less).
    - e. Golf course/club.
    - f. Guest house (site plan review).
    - g. Reserved.
    - h. Mobile home (one unit per 2.5 acres).
    - i. Roadside produce stand.
    - j. Silviculture.
    - k. Single-family conventional (one unit per 2.5 acres).
    - l. Special use (see section 24-234).
    - m. Temporary use (see section 24-234).
  - (2) Additionally, within any RCMH 2.5 district the following accessory uses and structures are allowed:
    - a. Storage buildings, sheds, tool houses and private garages.
    - b. Noncommercial greenhouses and plant nurseries.
    - c. Play equipment.

- d. Household pets.
- e. Swimming pools.

(c) *Permissible uses by special exception.*

- (1) Private riding stable (site plan review; see section 24-148(c)).
- (2) Public riding stable (site plan review; see section 24-148(d)).
- (3) Veterinarian clinic (site plan review).
- (4) Wireless telecommunication facilities (see section 24-235).
- (5) Semi-public uses.
  - a. Club.
  - b. Lodge.
  - c. Recreational association.
  - d. Neighborhood association.
  - e. Cultural activities.

(d) *Permissible uses by limited notice.*

- (1) Day care center.
- (2) Home occupation.

(e) *Setback and other standards.*

- (1) Minimum lot requirements (width, depth and area).
  - a. Width: 200 feet.
  - b. Area: 2.5 acres.
  - c. Depth: 300 feet.
- (2) Maximum lot coverage by all buildings and structures.
  - a. Not applicable.
- (3) Minimum yard requirements.
  - a. Front: 50 feet.
  - b. Side: 30 feet.
  - c. Rear: 50 feet.
- (4) Maximum height of structures. Maximum height of structures shall be 45 feet.

**DEVELOPMENT REVIEW COMMITTEE COMMENTS**

The application was circulated to the DRC Members, and the following reflect their comments:

Baker County Fire and Rescue / Trevor Nelson

- 1. No issues.

Public Works Department / Chris Lee

- 1. No issues.

Baker County Health Department / Ryan McFadden

- 1. No issues.

Baker County School District / Chadd Scarborough

- 1. No comments.

County Manager / Sara Little

- 1. No issues.

**RECOMMENDATION**

Staff recommends **APPROVAL** of the proposed Rezoning application for **Ordinance 2026-05** from **AGRICULTURE 7.5 (AG 7.5)** to **RESIDENTIAL CONVENTIONAL MOBILE HOME 2.5 (RCMH 2.5)**.

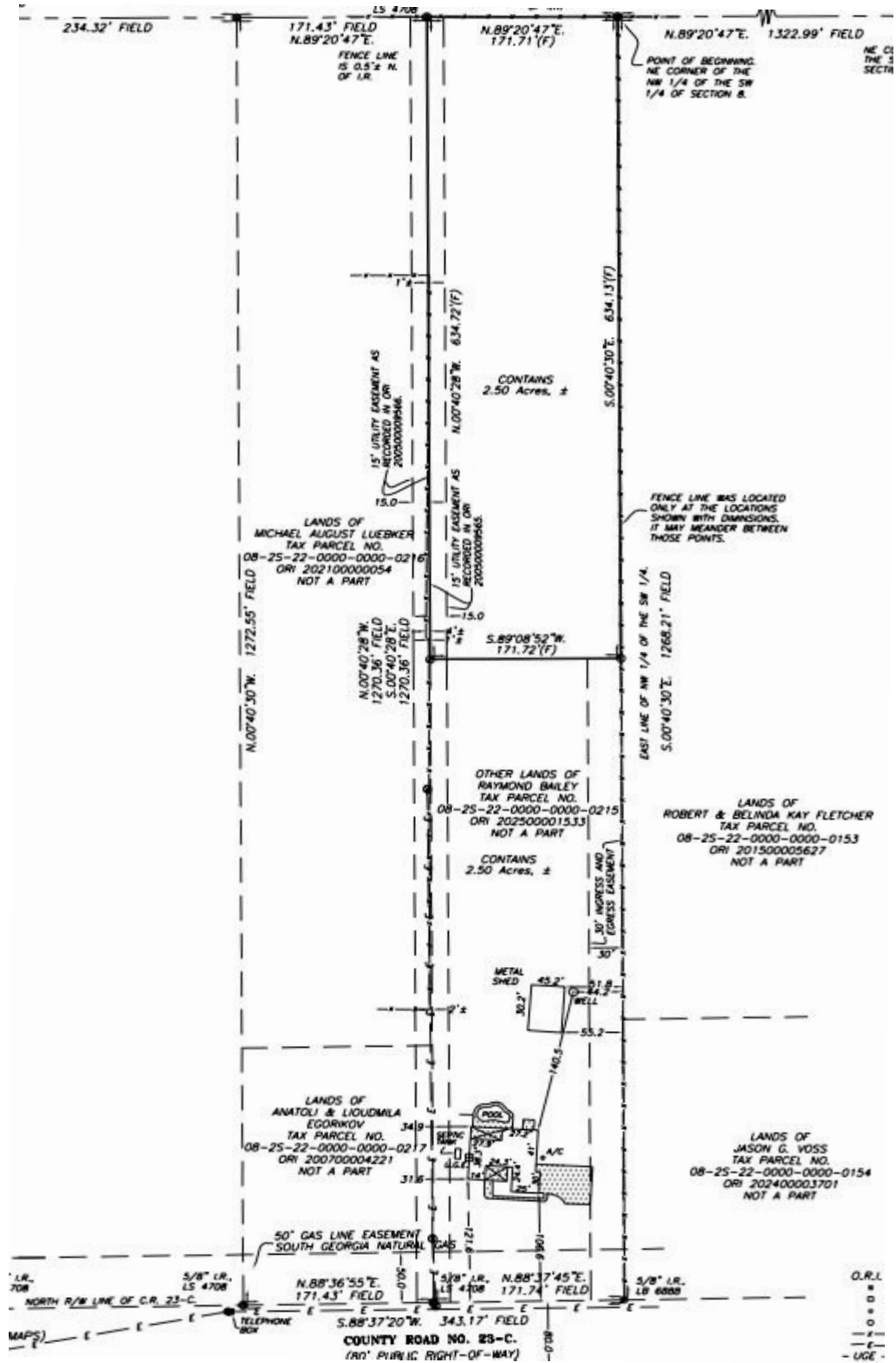

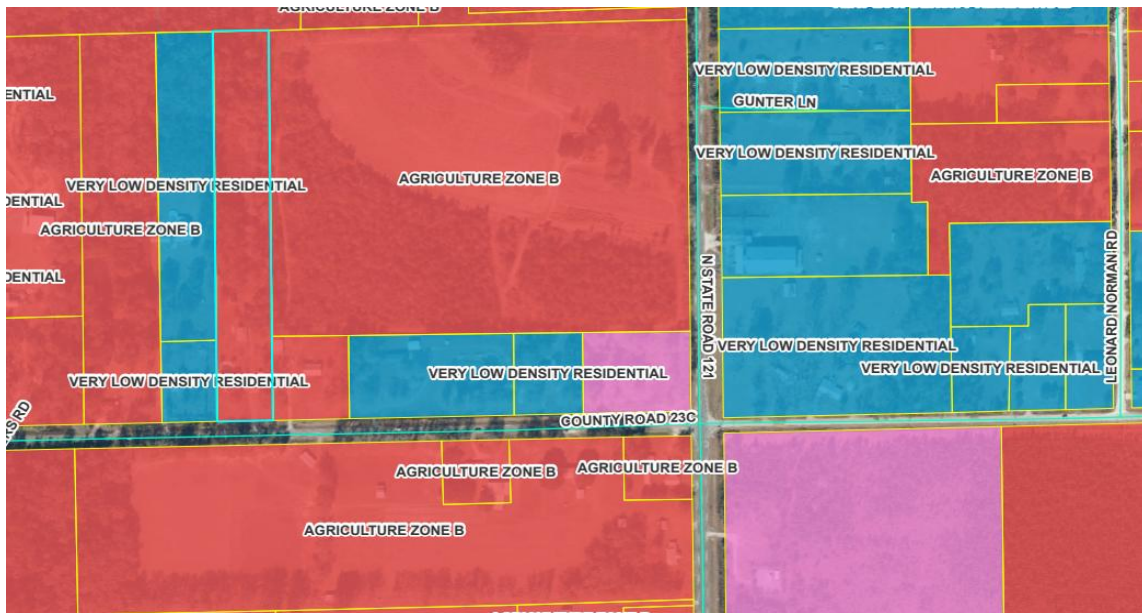
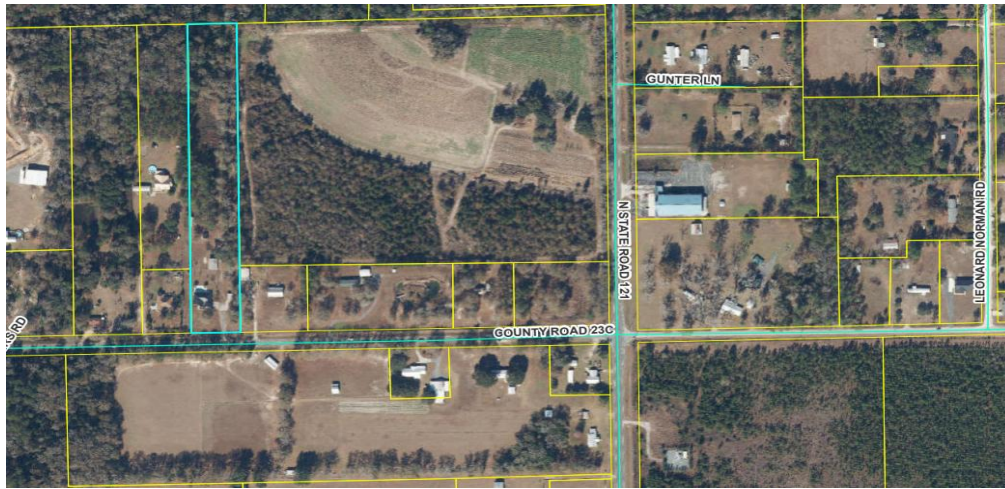

**ORDINANCE 2026-05**

**AN ORDINANCE OF THE BOARD OF COUNTY COMMISSIONERS OF BAKER COUNTY, FLORIDA AMENDING THE BAKER COUNTY ZONING MAP BY RECLASSIFYING APPROXIMATELY 5.01 +/- ACRES OF REAL PROPERTY OWNED BY RAYMOND & KAREN BAILEY FROM AGRICULTURE 7.5 (AG 7.5) TO RESIDENTIAL CONVENTIONAL AND MOBILE HOME 2.5 (RCMH 2.5) WITH THE INTENT OF BRINGING THE PARCEL INTO COMPLIANCE WITH ITS ACREAGE; PROVIDING FOR A CHANGE OF ZONING; PROVIDING DIRECTIONS FOR RECORDING; PROVIDING FOR SEVERABILITY; AND PROVIDING AN EFFECTIVE DATE.**

**WHEREAS**, the Community Planning Act; Section 163.3161 through 163.3215, Florida Statutes, require that each local government prepare and adopt a comprehensive land use plan, Zoning Map, and regulations; and

**WHEREAS**, the Board of County Commissioners of Baker County, Florida wishes to amend the Baker County Zoning Map; and

**WHEREAS**, the proposed zoning change is for approximately **5.01 +/- acres** of real property owned by **RAYMOND & KAREN BAILEY**; and

**WHEREAS**, the corresponding parcel identification number is **08-2S-22-0000-0000-0215**; and

**WHEREAS**, a duly advertised public hearing was conducted on **Tuesday, March 10, 2026 after 6:00 P.M.** by the Baker County Land Planning Agency (LPA); and the LPA provided its recommendations to the Board of County Commissioners of Baker County, Florida; and

**WHEREAS**, the Board of County Commissioners of Baker County, Florida held a duly advertised public hearing on **Tuesday, March 17, 2026 after 6:00 P.M.** for the purpose of hearing public comments; and

**WHEREAS**, the Board of County Commissioners of Baker County, Florida considered the recommendations of the LPA at the duly advertised public hearing held on **Tuesday, April 7, 2026 after 6:00 P.M.** and approved the Rezoning; and

**WHEREAS**, the Board of County Commissioners of Baker County, Florida finds that the adoption of this ordinance for the Rezoning, the amendment to the Baker County Zoning Map, and the reclassification of real property described herein is consistent with the Goals, Objectives, and

Policies of the Baker County Comprehensive Plan and the Land Development Regulations of the Baker County Ordinance Code and is in the best interest of Baker County, Florida and its citizens.

**NOW THEREFORE, BE IT ORDAINED** by the Board of County Commissioners of Baker County, Florida as follows:

Section 1. Adoption and Incorporation of Recitals. The Board of County Commissioners of Baker County, Florida hereby adopts the above recitals and incorporates them herein as a part of this ordinance.

Section 2. Ownership and Description of Property. The real property reclassified by this Ordinance is owned by **RAYMOND & KAREN BAILEY** and identified by the Baker County Property Appraiser Identification Number: **08-2S-22-0000-0000-0215**; and is more particularly described in “Exhibit 1” which is attached hereto and incorporated herein by reference.

Section 3. Purpose and Authority of Ordinance. This Ordinance is adopted for the purpose of rezoning the above described real property pursuant to chapter 24 of the Baker County Land Development Regulations.

Section 4. Direction to Staff. Following approval by the Board of County Commissioners of Baker County, Florida, the staff of the Community Development Department is directed to file the same in the Official Records of Baker County, Florida.

Section 5. Recording of Ordinance. Following approval by the Board of County Commissioners of Baker County, Florida, the staff of the Clerk of the Court is directed to file the same in the Official Records of Baker County, Florida.

Section 6. Effective Date of Ordinance. This Ordinance shall become effective upon adoption by the Board of County Commissioners of Baker County, Florida.

**PASSED AND ADOPTED** with a quorum present and voting, by the Board of County Commission of Baker County, Florida, in regular session, this **Tuesday, April 7, 2026**.

**BOARD OF COUNTY COMMISSIONERS OF  
BAKER COUNTY, FLORIDA**

---

**RONALD MANN, CHAIR  
COUNTY COMMISSION**

**ATTEST:**

---

**STACIE HARVEY  
CLERK OF THE BOARD**

## EXHIBIT 1

Part of the NW 1/4 of the SW 1/4 of Section 8, Township 2 South, Range 22 East, Baker County, Florida, more particularly described as follows:

Commence at the NW corner of the NW 1/4 of the SW 1/4 of said Section 8 and thence North 89°20'47" East, along the North line of said NW 1/4 of the SW 1/4 a distance of 979.85 feet; thence continue North 89°20'47" East, 171.43 feet to the Point of Beginning; thence continue North 89°20'47" East, 171.71 feet to the NE corner of said NW 1/4 of the SW 1/4; thence South 00°40'30" East, along the East line of said NW 1/4 of the SW 1/4, a distance of 1268.21 feet to the North right-of-way line of County Road No. 23-C, an 80 foot wide public right of way; thence South 88°37'20" West, along said North right-of-way line, 171.74 feet; thence North 00°40'28" West, 1270.36 feet to the Point of Beginning.

Subject to a 50 foot wide gas line easement over and across the South 50 feet of the above described lands.